

**SINTEF Building and Infrastructure**

P.O.Box 124 Blindern

N-0314 Oslo

Tel. 47 22 96 55 55

Fax 47 22 69 54 38



Authorised and notified according to Article 10 of the Council Directive 89/106/EEC of 21 December 1988 on the approximation of laws, regulations and administrative provisions of Member States relating to construction products

**MEMBER OF EOTA**

## **European Technical Approval ETA-10/0109**

(Final version 31.05.2010)

Trade name:	Hilti Firestop Foam CFS-F FX
Holder of the approval:	HILTI Corporation Feldkircherstrasse 100 9494 Schaan Liechtenstein
Generic type and use of construction product:	Fire Stopping and Sealing Product. Penetration Seals
Valid from:	2010-05-31
to:	2015-05-31
Manufacturing plant:	HILTI Werk 4a
This European Technical Approval contains:	38 pages including 5 Annexes which form an integral part of the document



**European Organisation for Technical Approvals**  
**Europäische Organisation für Technische Zulassungen**  
**Organisation Européenne pour l'Agrément technique**

## I LEGAL BASIS AND GENERAL CONDITIONS

- 1 This European Technical Approval is issued by SINTEF Building and Infrastructure, in the following called SINTEF, in accordance with:
  - Council Directive 89/106/EEC of 21 December 1988 on the approximation of laws, regulations and administrative provisions of Member States relating to construction products<sup>1</sup>, modified by the Council Directive 93/68/EEC<sup>2</sup> and Regulation (EC) N° 1882/2003 of the European Parliament and of the Council<sup>3</sup>
  - Common Procedural Rules for Requesting, Preparing and the Granting of European technical approvals set out in the Annex of Commission Decision 94/23/EC<sup>4</sup>
  - ETAG No 026 Fire Stopping and Fire Sealing Products Part 1: “General” and Part 2: “Penetration seals”
- 2 SINTEF is authorised to check whether the provisions of this European Technical Approval are met. Checking may take place in the manufacturing plant. Nevertheless, the responsibility for the conformity of the products to the European Technical Approval and for their fitness for the intended use remains with the holder of the European Technical Approval.
- 3 This European Technical Approval is not to be transferred to manufacturers or agents of manufacturers other than those indicated on page 1 of this European Technical Approval.
- 4 This European Technical Approval may be withdrawn by SINTEF in particular pursuant to information by the Commission according to Article 5(1) of Council Directive 89/106/EEC.
- 5 Reproduction of this European Technical Approval including transmission by electronic means shall be in full. However, partial reproduction can be made with the written consent of SINTEF. In this case partial reproduction has to be designated as such. Texts and drawings of advertising brochures shall not contradict or misuse the European Technical Approval.
- 6 The European Technical Approval is issued by the approval body in its official language. This version corresponds fully to the version circulated in EOTA. Translations into other languages have to be designated as such.

---

<sup>1</sup> Official Journal of the European Communities N° L40, 11.2.1989, p. 12

<sup>2</sup> Official Journal of the European Communities N° L 220, 30.08.1993, p. 1

<sup>3</sup> Official Journal of the European Union N° L 284, 31.10.2003, p. 1

<sup>4</sup> Official Journal of the European Communities N° L17, 20.1.1994, p. 34

## II SPECIFIC CONDITIONS OF THE EUROPEAN TECHNICAL APPROVAL

### 1 Definition of product and intended use

#### 1.1 Definition of the construction product

##### 1.1.1 Hilti Firestop Foam CFS-F FX

Hilti Firestop Foam CFS-F FX is a product to form a penetration seal used to reinstate the fire resistance performance of wall and floor constructions, where they have been provided with apertures for the penetration of services.

Hilti Firestop Foam CFS-F FX is a two-component foam composed essentially of expanding substances and binder.

##### 1.1.2 Additional components

Hilti Firestop Bandage CFS-B is an intumescent wrap used together with Hilti Firestop Foam CFS-F FX in pipe penetration seals including metal pipes insulated with combustible insulation (reaction to fire class B to E according to EN 13501-1) and plastic pipes. Hilti Firestop Bandage CFS-B consists of an intumescent component on a carrier made from fibre glass fabric.

### 1.2 Intended use and use category

#### 1.2.1 Intended use

Hilti Firestop Foam CFS-F FX may be used to provide a penetration seal around services running through openings of maximum dimensions  $w \times h = 400 \times 400$  mm in walls and floors with minimum thickness as given in the tables in Annex C and D related to declared fire resistances. Further details on the type of services covered by the declared classifications and other parameters to be considered are also given in Annex C and D.

- (1) The specific structures where Hilti Firestop Foam CFS-F FX may be used to provide a penetration seal are as follows:

**Flexible walls:** The wall must have a minimum thickness of 112 mm and comprise timber or steel studs lined on both faces with minimum 2 layers of 12.5 mm thick boards. For timber stud walls there must be a minimum distance of 100 mm between the seal and any stud, and the cavity must be filled with minimum 100 mm insulation of Class A1 or A2 in accordance with EN 13501-1).

**Rigid walls:** The wall must have a minimum thickness of 112 mm and comprise concrete, aerated concrete or masonry, with a minimum density of  $650 \text{ kg/m}^3$ .

**Rigid floors:** The floor must have a minimum thickness of 150 mm and comprise aerated concrete or concrete with a minimum density of  $2200 \text{ kg/m}^3$ .

The supporting construction must be classified in accordance with EN 13501-2 for the required fire resistance.

This ETA does not cover use of this product as a penetration seal in sandwich panel constructions.

- (2) Hilti Firestop Foam CFS-F FX may be used to provide a penetration seal with the following specific services, single, multiple or in combination:

Blank seal	As given in Annex C.1
Cables / cable trays	Services as given in Annex C.2
Conduits	Services as given in Annex C.3
Metal pipes	Services as given in Annex C.4 and Annex D
Plastic pipes	Services as given in Annex C.5
Mixed	Services as given in Annex E

- (3) Pipes and cable support constructions shall be supported at maximum 300 mm and 500 mm away from both faces of wall constructions and maximum 250 mm and 415 mm from the upper face of floor constructions.

The provisions made in this European Technical Approval are based on an assumed working life of penetration seals made from Hilti Firestop Foam CFS-F FX of 10 years, provided that the conditions laid down in sections 4.2/5.1/5.2 for the packaging / transport / storage / installation / use / repair are met. The indications given on the working life cannot be interpreted as a guarantee given by the producer, but are to be regarded only as a means for choosing the right products in relation to the expected economically reasonable working life of the works.

### 1.2.2 Use category

This ETA covers a fire stopping and sealing product intended for use at temperatures below 0°C, but with no exposure to rain nor UV. The environmental condition described by use category according to ETAG 026-2 is type Y<sub>2</sub>, (-20/+70)°C. Since the requirements for type Y<sub>2</sub> are met, also the requirements for type Z<sub>1</sub> and Z<sub>2</sub> are fulfilled.

## 2 Characteristics of products and methods of verification

### 2.0 General

The assessment of fitness for use has been made in accordance with ETAG No 026 - Part 2: 2008-01-01, summarized as follows:

ETAG Clause No.	ETA Clause No.	Characteristic	Assessment of characteristic
		<b>Mechanical resistance and stability</b>	Not relevant
		<b>Safety in case of fire</b>	
2.4.1	2.1	Reaction to fire	Class E according to EN 13501-1
2.4.2	2.2	Resistance to fire	See clause 2.2
		<b>Hygiene, Health and the Environment</b>	
2.4.3	2.3	Air permeability	Flow rate per area
2.4.4	2.4	Water permeability	No performance determined
2.4.5	2.5	Dangerous substances	See clause 2.5
		<b>Safety in use</b>	
2.4.6	2.6	Mechanical resistance and stability	See clause 2.6
2.4.7	2.7	Resistance to impact/movement	Zone type I to IV according to EOTA TR001
2.4.8	2.8	Adhesion	See clause 2.8
		<b>Protection against noise</b>	
2.4.9	2.9	Airborne sound insulation	$R_{w(C;Ctr)}$ , $D_{n,e,w}$
		<b>Energy, Economy and Heat Retention</b>	
2.4.10	2.10	Thermal properties	No performance determined
2.4.11	2.11	Water vapour permeability	No performance determined
		<b>General aspects relating to fitness for use</b>	
2.4.12	2.12	Durability and serviceability	$Y_{2, (-20/+70)^{\circ}C}$ Compatibility with coatings

### 2.1 Reaction to fire

The reaction to fire classification for Hilti Firestop Foam CFS-F FX in the cured state is class E according to EN 13501-1.

### 2.2 Resistance to fire

The classification of the resistance to fire performance has been carried out in accordance with clause 7.5.8 in EN 13501-2:2007. Penetration seals made from Hilti Firestop Foam CFS-F FX with additional materials and services are classified according to combinations of performance parameters and classes as shown in Annex C, D and E. The classifications are valid for services running through openings of maximum dimensions  $w \times h = 400 \times 400$  mm, in flexible and rigid walls with minimum thickness  $t_E = 112$  mm and 150 mm respectively and concrete floors

with minimum thickness 150 mm. The classifications require that the rules for installation shown in cl. 4.2 are followed.

The classifications are not valid for sandwich panel constructions.

Where the required seal thickness is higher than the wall or floor thickness, a support frame ( $E_1$ ) made from material of class A1 or A2 according to EN 13501-1 (e.g. gypsum board) shall be installed to support the Hilti Firestop Foam CFS-F FX as illustrated in Fig. 1. The frame may be installed inside the opening, its depth being minimum the seal thickness  $t_A$ , in case of a penetration seal in a wall centred in relation to the wall. Alternatively a frame made from gypsum board may be fixed to the wall or floor around the opening (width  $w_A \geq 50$  mm for wall applications,  $w_A \geq 75$  mm for floor applications, total thickness wall plus frame  $\geq$  seal thickness  $t_A$ ). The frame must be fixed by minimum 2 metal screws per side of the frame with a maximum distance of 150 mm between the screws. In case of a penetration seal in a wall the frame shall be installed on both sides so that the penetration seal is centred in relation to the wall.

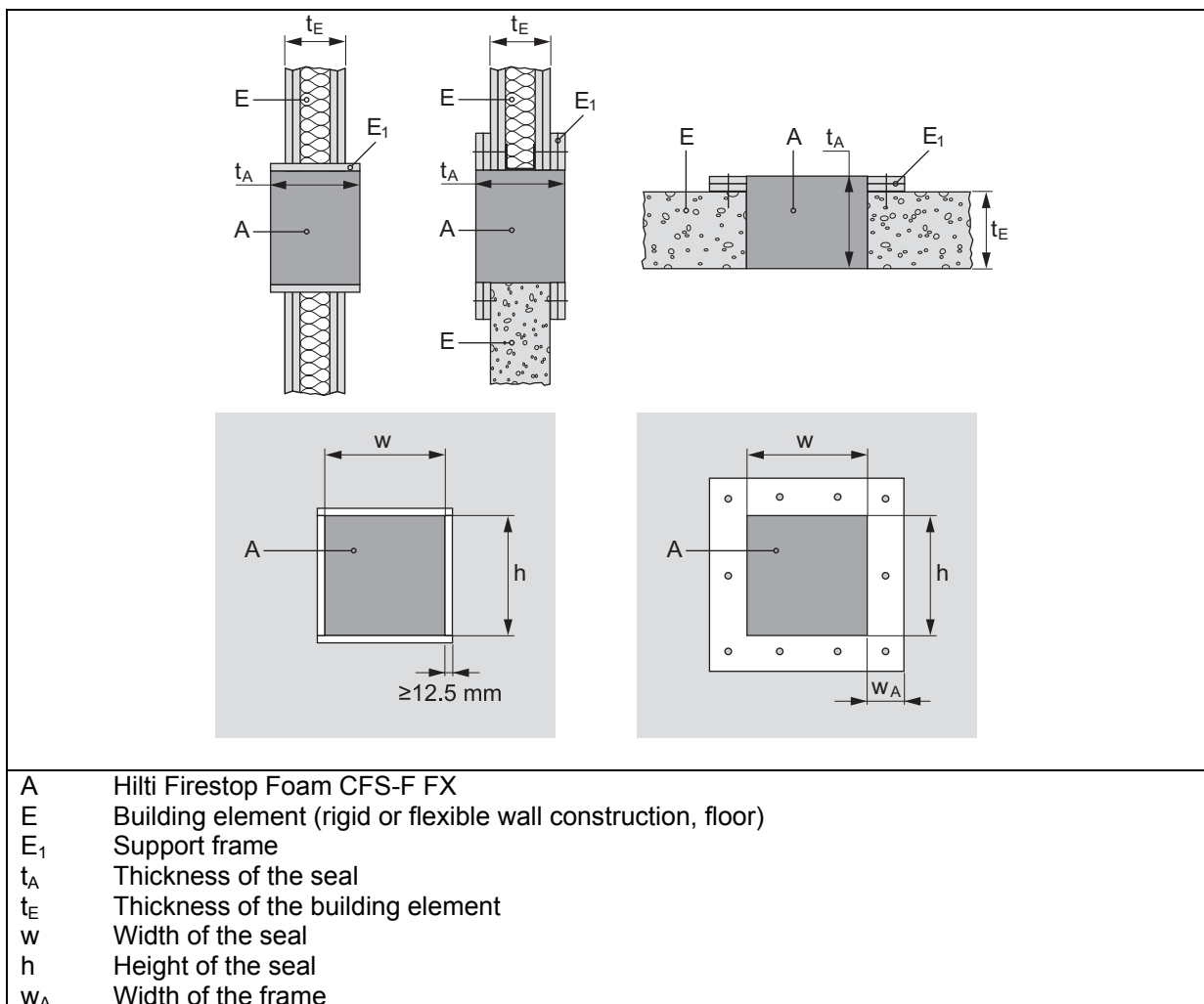

Fig. 1  
Options for support frames (seal thickness higher than wall/floor thickness)

In case of a flexible wall with no insulation between the panels, an insulation that does not fill the space between the linings completely, an insulation of a density of less than  $100 \text{ kg/m}^3$  or an insulation made from glass wool, an aperture framing has to be installed. It has to be made from material used to construct the wall, i.e. studs and boards with a minimum board thickness of 12.5 mm, as illustrated in Figure 2.

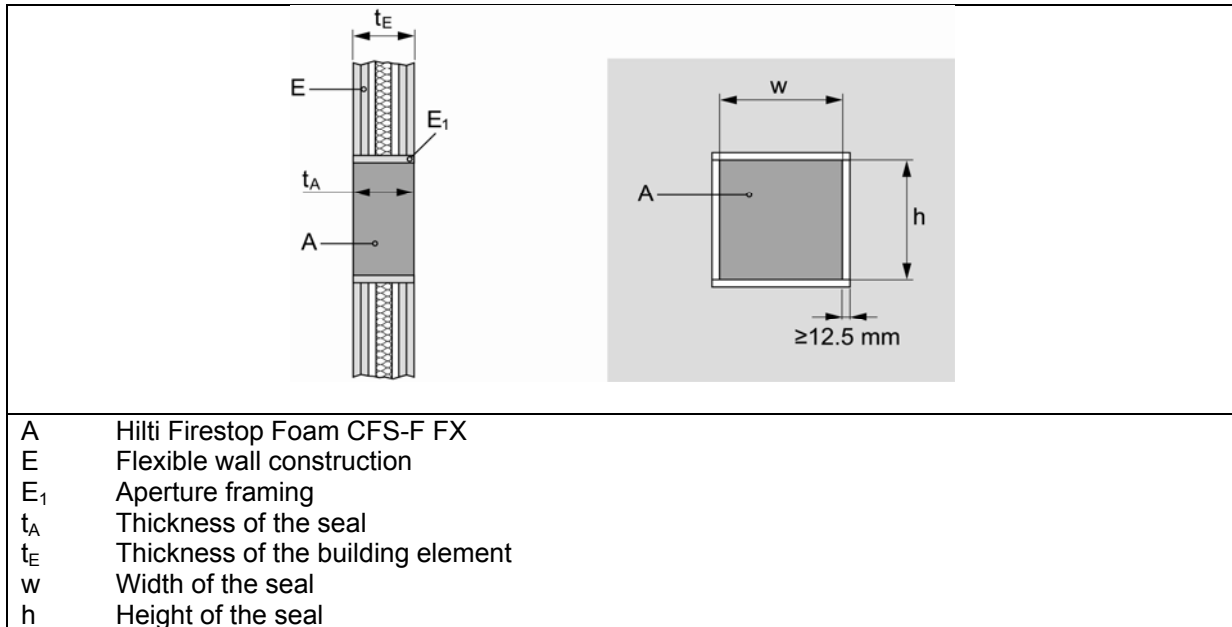

Fig. 2  
Aperture framing

### 2.3 Air permeability, and permeability regarding some other gases

The permeability has been tested according to EN 1026.

The following two flow rates ( $q$ ) per area ( $A$ ) for air permeability were achieved for the given air pressure differences ( $\Delta p$ ):

$\Delta p$ [ Pa]	$q / A$ [m <sup>3</sup> /(h· m <sup>2</sup> )]	Layer thickness [mm]
50	0,0007	174
250	0,0033	174

The permeability regarding the gases N<sub>2</sub>, CO<sub>2</sub> and CH<sub>4</sub> (Methane) has been determined as follows for foam layer with thickness 174 mm, and where the flow rate index  $q$  indicates the type of gas:

$\Delta p$ [ Pa]	$q_{N_2} / A$ [m <sup>3</sup> /(h·m <sup>2</sup> )]	$q_{CO_2} / A$ [m <sup>3</sup> /(h·m <sup>2</sup> )]	$Q_{CH_4} / A$ [m <sup>3</sup> /(h·m <sup>2</sup> )]
50	0,0006	0,0004	0,0007
250	0,0031	0,0021	0,0035

The declared values refer to a penetration seal made from Hilti Firestop Foam CFS-F FX without any penetrating installation.

### 2.4 Water permeability

No performance determined.

### 2.5 Dangerous substances

According to the DEKRA test report no. 77801/07 with reference to the project no. 55077801, signed and dated 2007-06-06, the resulting air contamination will be kept below any respective occupational exposure limits as far as such limits exist. It is assumed that relevant recommendations given in Hilti's Material Safety Data Sheet according to 1907/2006/EC, Article 31 will be followed.

Hilti AG has presented a Material Safety Data Sheet according to Regulation 1907/2006/EC and a declaration that Hilti Firestop Acrylic Sealant CFS-S ACR is in compliance with Regulation 1907/2006/EC concerning the Registration, Evaluation, Authorisation and Restriction of Chemicals (REACH).

Confirmation has further been declared that no toxic, carcinogenic, toxic for reproduction and mutagenic chemical substances of category 1 or 2  $\geq 0.1$  % w/w (Status: Regulation 790/2009/EC - 1st ATP of the Regulation 1272/2008/EC) that would lead to classification T and sentences R45 and/or R46 are used in Hilti Firestop Foam CFS-F FX and that all other dangerous substances have been considered for the classification of the product according to the Regulation



1272/2008/EC (classification, labelling and packaging of substances and mixtures, including amendments)

In addition to the specific clauses relating to dangerous substances contained in this European Technical Approval, there may be other requirements applicable to the products falling within its scope (e.g. transposed European legislation and national laws, regulations and administrative provisions). In order to meet the provisions of the EU Construction Products Directive, these requirements need also to be complied with, when and where they apply.

## **2.6 Mechanical resistance and stability**

It is assumed that the impact test shown in cl. 2.7 covers both static and dynamic loads.

## **2.7 Resistance to impact/movement**

A 200 mm thick concrete wall with a penetration seal made from Hilti Firestop Foam CFS-F FX, dimensions 400 mm x 400 mm, without penetrating services, has been tested in accordance with EOTA Technical Report - TR001 - Edition February 2003. The results demonstrate suitability for all the following applications foreseen in EOTA Technical Report - TR001, A.1:

Type I: Zones accessible primarily to those with high incentive to exercise care. Small risk of accidents occurring and of misuse.

Type II: Zones accessible primarily to those with some incentive to exercise care. Some risk of accidents occurring and of misuse.

Type III: Zones readily accessible to public and others with little incentive to exercise care. Risk of accidents occurring and of misuse.

Type IV: Zones and risk as II and III. In case of failure, risk includes the fall to a floor at a lower level.

## **2.8 Adhesion**

It is assumed that verification of adequate adhesion is covered by the impact tests shown in cl. 2.7.

## **2.9 Airborne sound insulation**

Measurements according to EN ISO 140-3 and EN ISO 20140-10 on double metal frame partition wall structure with size 1.25 m x 1.50 m, each leaf with 2 x 12.5 mm gypsum board lining and 50 mineral wool insulation, 5 mm air gap between leaves, and 0.4 m x 0.4 m penetrated centre filled with Hilti Firestop Foam CFS-F FX, showed the following result according EN ISO 717-1:

Weighted sound reduction index:  $R_w(C;Ctr) = 47(-1;-6)$  dB

Weighted element-normalized level difference:  $D_{n,e,w}(C;Ctr) = 54(-0;-5)$  dB

Regarding the value  $D_{n,e,w}$  (C;Ctr):  $A_0 = 10 \text{ m}^2$  (reference area according to EN ISO 20140-10)

## **2.10 Thermal insulation**

No performance determined.

## **2.11 Water vapour permeability**

No performance determined.

## **2.12 Durability and serviceability**

### **2.12.1 Durability**

Hilti Firestop Foam CFS-F FX has been tested in accordance with EOTA Technical Report - TR024 - Edition November 2006, Table 4.1, for the type  $Y_2$  use category specified in EOTA 026-2. The results of the tests have demonstrated suitability for penetration seals intended for use at temperatures between  $-20^\circ\text{C}$  and  $+70^\circ\text{C}$ , but with no exposure to rain nor UV.

### **2.12.2 Serviceability**

Hilti Firestop Foam CFS-F FX has been tested in combination with coatings based on an acrylic dispersion, alkyd resin, polyurethane/acrylic and epoxy resin. The results of the test have demonstrated suitability of penetration seals made from Hilti Firestop Foam CFS-F FX for being painted over by those types of coatings.

## **3 Evaluation and attestation of conformity and CE marking**

### **3.1 System of attestation of conformity**

According to the decision 1999/454/EC of the European Commission<sup>5</sup> the system 1 of attestation of conformity applies.

This system of attestation of conformity is defined as follows:

System 1: Certification of the conformity of the product by an approved certification body on the basis of:

(a) Tasks for the manufacturer:

- (1) factory production control;
- (2) further testing of samples taken at the factory by the manufacturer in accordance with a prescribed test plan;

(b) Tasks for the notified body:

- (3) initial type-testing of the product;

---

<sup>5</sup> Official Journal of the European Communities L178/52 of 22 June 1999

- (4) initial inspection of factory and of factory production control;
- (5) continuing surveillance, assessment and approval of factory production control

## **3.2 Responsibilities**

### **3.2.1 Tasks of the manufacturer**

#### *3.2.1.1 Factory production control*

The manufacturer shall exercise permanent internal control of production. All the elements, requirements and provisions adopted by the manufacturer shall be documented in a systematic manner in the form of written policies and procedures, including records of results performed. This production control system shall insure that the product is in conformity with this European technical approval.

The manufacturer may only use constituent materials stated in the technical documentation of this European technical approval.

The factory production control shall be in accordance with the Control Plan dated 12.02.2007, which is part of the technical documentation of this European technical approval. The Control Plan is laid down in the context of the factory production control system operated by the manufacturer and deposited at SINTEF.

The results of factory production control shall be recorded and evaluated in accordance with the provisions of the Control Plan.

#### *3.2.1.2 Other tasks of manufacturer*

The manufacturer shall provide a technical data sheet and an installation instruction with the following minimum information:

Technical data sheet

- Field of application:
  - Building elements for which the penetration seal is suitable, type and properties of the building elements like minimum thickness, density, and - in case of lightweight constructions - the construction requirements.
  - Services for which the penetration seal is suitable, type and properties of the services like material, diameter, thickness etc. in case of pipes including insulation materials; necessary/allowed supports/fixings (e.g. cable trays)
  - Limits in size, minimum thickness etc. of the penetration seal
- Construction of the penetration seal including the necessary components and additional products (e.g. backfilling material) with clear indication whether they are generic or specific.

Installation instruction:

- Steps to be followed
- Procedure in case of retrofitting

The manufacturer shall, on the basis of a contract, involve a body (bodies) which is (are) approved for the tasks referred to in section 3.1 in the field of penetration seals in order to undertake the actions laid down in section 3.3. For this purpose, the control plan referred to in sections 3.2.1.1 and 3.2.2 shall be handed over by the manufacturer to the approved body or bodies involved.

The manufacturer shall make a declaration of conformity, stating that the construction product is in conformity with the provisions of this European technical approval.

### **3.2.2 Tasks of approved bodies**

The approved body (bodies) shall perform the

- initial type-testing of the product,
- initial inspection of factory and of factory production control,
- continuous surveillance, assessment and approval of factory production control,

in accordance with the provisions laid down in the Control Plan dated 12.02.2007, relating to this European technical approval.

The approved body (bodies) shall retain the essential points of its (their) actions referred to above and state the results obtained and conclusions drawn in (a) written report (reports).

The approved certification body involved by the manufacturer shall issue an EC certificate of conformity of the product stating the conformity with the provisions of this European technical approval.

In cases where the provisions of the European technical approval and its Control Plan are no longer fulfilled the certification body shall withdraw the certificate of conformity and inform SINTEF without delay.

### **3.3 CE-marking**

The CE marking shall be affixed on the packaging of the HILTI Firestop Foam CFS-F FX. The marking „CE“ shall be followed by the identification number of the approved certification body and be accompanied by the following additional information:

- a) the name and address of the producer (legal entity responsible for the manufacturer)
- b) the two last digits of the year in which the CE marking was affixed

- d) the number of the EC Certificate of conformity for the product
- e) the number of the European technical approval
- f) reference to ETAG 026, Part 2
- g) indications to clarify the intended use

Example of CE-Marking:

	"CE"-Marking
xxxx	Number of Notified Body
HILTI Corporation Feldkircherstrasse 100 9494 Schaan Liechtenstein	Name and address of the producer (legal entity responsible for placing the product onto the market)
09	Two last digits of year of affixing CE- Marking
1166-CPD-xxxx	Number of EC certificate of conformity (where relevant)
ETA N° 10/109	ETA Number
ETAG 026, Part 2	ETAG Number
Penetration Seal Hilti Firestop Foam CFS-F FX  Use category Y <sub>2</sub> , (-20/+70) <sup>o</sup> C  See ETA 10/109 for other relevant characteristics	Designation of the product  Use category  Other information

### 3.4 Other marking and/or information

The batch number of the components is shown on the foil bags for each component. The product name and expiry date (MM/YYYY) is printed on the connecting element of the foil pack. See also the instructions for use in Annex F regarding expiry date.

## **4 Assumptions under which the fitness of the product for the intended use was favourably assessed**

### **4.1 Manufacturing**

The European technical approval is issued for Hilti Firestop Foam CFS-F FX on the basis of agreed data/information deposited with SINTEF, which identifies the product that has been assessed and judged. Changes to the product or production process, which could result in this deposited data/information being incorrect, should be notified to SINTEF before the changes are introduced. SINTEF will decide whether or not such changes affect the ETA and consequently the validity of the CE marking on the basis of the ETA, and if so whether further assessment or alterations to the ETA is necessary.

### **4.2 Installation**

#### **4.2.1 General**

The fire stopping and fire sealing product shall be installed according to the manufacturer's instructions. It is the manufacturer's responsibility to provide correct information about the application to the users. See Annex F.

#### **4.2.2 Cable seals**

For tied cable bundles<sup>6</sup> the space between the cables needs not be sealed.

The total cross section of the cables (including cable supporting systems like cable trays etc.) must not be more than 60% of the total seal (opening) size.

#### **4.2.3 Pipe seals**

Pipes must be perpendicular to the seal surface.

Plastic pipes shall be used for non-combustible liquids and fluids only, or for pneumatic dispatch systems and for vacuum cleaning pipes.

It is assumed that compressed air systems are switched off by other means in the case of fire.

The function of the pipe seal in case of pneumatic dispatch systems, pressurized air systems etc. is guaranteed only when the systems are shut off in case of fire.

The assessment does not cover the avoidance of destruction of the seal or of the abutting building element(s) by forces caused by temperature changes in case of fire. This has to be considered when designing the piping system.

#### **NOTE**

For example, for non-insulated metal pipes the elongation to be considered can be calculated using the relevant temperature from the standard time temperature curve at the fire resistance period required.

---

<sup>6</sup> Several cables running in the same direction and bound closely together by mechanical means

The approval does not address any risks associated with leakage of dangerous liquids or gases caused by failure of the pipe(s) in case of fire.

The durability assessment does not take account of the possible effect of substances permeating through the pipe on the penetration seal.

It is assumed that thermal movement in the pipe work will be accommodated in such a way that it does not impose a load on the penetration seal.

#### **4.2.4 Design**

Other parts or support constructions than given in Annex C, D and E must not penetrate the seal. Provisions shall be taken such that floor penetration seals cannot be stepped on or are not subjected to forces higher than the limit taken from the impact tests, e.g. by covering with a wire mesh.

The service support construction must be fixed to the building element on both sides of the penetration in such a manner that in the case of fire no additional load is imposed on the seal. Furthermore it is assumed that this support is maintained for the required period of fire resistance.

#### **4.2.5 Tool and equipment for application**

Hilti Firestop Foam CFS-F FX may be applied with a Hilti MD 2000 (manual) or ED 3500 dispenser (battery). See also the installation instruction in Annex F.

#### **4.2.6 Applications including Hilti Firestop Bandage CFS-B**

Two layers of Hilti Firestop Bandage CFS-B are tightly wrapped around the pipe or pipe insulation on both sides of the opening. The bandage is positioned so that the line marking at the mid of the bandage is flush with the surface of the penetration seal (special care has to be taken to use the correct position when the required Hilti Firestop Foam CFS-F FX seal thickness is higher than the wall or floor thickness). The bandage is fixed with steel wire and the remaining opening filled with Hilti Firestop Foam CFS-F FX.

### **5 Indications to the manufacturer and supplier**

#### **5.1 Packaging, transport and storage**

The following measures should be adopted with regard to handling and storage of the Hilti Firestop Foam CFS-F FX:

- For safe handling the provisions of the Material Safety Data Sheet for the product shall be followed
- Storage and transport temperatures are 5 °C to 25 °C
- Shelf life is 9 months (at 23 °C and stored in a dry place)

For additional information see also Annex B.

## **5.2 Use, maintenance and repair**

The product does not need any maintenance in the life time indicated in the ETA.

The assessment of the fitness for use is based on the assumption that damage, for example caused by accidental impact, is repaired. The manufacturer's installation instructions and recommendations according to the Material Safety Data Sheet for the product shall be followed.

SINTEF Building and Infrastructure

Oslo, 31.05.2010



Tore H. Erichsen  
Approval Manager



## REFERENCE DOCUMENTS and LIST of ABBREVIATIONS

### References to standards mentioned in the ETA:

EN 1026	Windows and doors – Air permeability – Test method
prEN 1366-3:2006	Fire resistance tests for service installations - Part 3: Penetration seals
EN 13238	Reaction to fire tests for building products: Conditioning procedures and general rules for selection of substrates
EN 13501-1	Fire classification of construction products and building elements – Part 1: Classification using test data from reaction to fire tests
EN 13501-2	Fire classification of construction products and building elements – Part 2: Classification using test data from fire resistance tests
EN 13823:2002	Reaction to fire tests for building products – Building products excluding floorings exposed to the thermal attack by a single burning item
EN ISO 140-3	Acoustics – Measurement of sound insulation in buildings and of building elements – Part 3: Laboratory measurements of airborne sound insulation of building elements
EN ISO 140-10	Acoustics – Measurements of sound insulation in buildings and of building elements – Part 10: Laboratory measurement of airborne sound insulation of small building elements
EN ISO 717-1	Acoustics – Rating of sound insulation of buildings and of building elements – Part 1: Airborne sound insulation
EN ISO 11925-2	Reaction to fire tests – Ignitability of building products subjected to direct impingement of flame – Part 2: Single-flame source test
HD 22.4	Cables of rated voltages up to and including 450/750 V and having crosslinked insulation – Part 4: Cords and flexible cables
HD 640.5	0.6/1kV Power cables with special fire performance for use in power stations – Part 5: single core and multicore halogen-free cables

### Other reference documents:

EOTA TR 001	Determination of impact resistance of panels and panel assemblies
EOTA TR 024	Characterisation, Aspects of Durability and Factory Production Control for Reactive Materials, Components and Products
Safety Data Sheet according to 1907/2006/EC, Article 31, for Hilti Firestop Foam CFS-F FX	

### Abbreviations used in drawings

Abbreviation	Description	Abbreviation	Description
A, A <sub>1</sub> , A <sub>2</sub> ,...	Firestop product	s <sub>1</sub> , s <sub>2</sub>	Distances
C, C <sub>1</sub> , C <sub>2</sub> ,...	Penetrating services	t <sub>A</sub>	Thickness of penetration seal
D	Pipe insulation	t <sub>c</sub>	Pipe wall thickness
E, E <sub>1</sub> , E <sub>2</sub> ,...	Building element (wall, floor)	t <sub>D</sub>	Thickness of insulation
L <sub>D</sub>	Length of insulation	t <sub>E</sub>	Thickness of the building element
d <sub>c</sub>	Pipe diameter	w	Width of penetration seal
h	Height/length of penetration seal		

## ANNEX A

### DESCRIPTION OF PRODUCT AND PRODUCT LITERATURE

#### Hilti Firestop Foam CFS-F FX

Foil pack 325ml



Mixing nozzle



Dispenser

MD 2000



ED 3500



- Technical Datasheet Hilti Firestop Foam CFS-F FX including Instructions for use Hilti Firestop Foam CFS-F FX

#### Hilti Firestop Bandage CFS-B



- Technical Datasheet Hilti Firestop Bandage CFS-B including Instructions for use Hilti Firestop Bandage CFS-B

**ANNEX B**

**RESISTANCE TO FIRE CLASSIFICATION OF  
HILTI FIRESTOP FOAM CFS-F FX**

**Blank seal**

Flexible and rigid wall constructions according to 1.2.1	
Penetration seal / Services	Classification
<b>Blank seal</b> – no services; Hilti Firestop Foam CFS-F FX (A) of thickness $t_A \geq 112$ mm centered regarding the thickness of the building element (E)	EI 120
<p>Construction details:</p>	
<p>For explanation of abbreviations see the related text and Annex A</p>	

## Cables

### Flexible and rigid wall constructions according to 1.2.1

Penetration seal / Services	Classification		
<b>Hilti Firestop Foam CFS-F FX (A)</b> of thickness $t_A$ (mm) centered regarding the thickness of the building element (E). All sheathed cable types currently and commonly used in building practice in Europe (e.g. power, control, signal, telecommunication, data, optical fibre cables with a diameter of:	$112 \leq t_A \leq 150$	$150 \leq t_A \leq 200$	$t_A \geq 200$
Maximum $\varnothing$ 21 mm	EI 60 / E 120	EI 60 / E 120	EI 120
21 $\leq$ $\varnothing$ $\leq$ 50 mm	-	EI 60 / E 120	EI 90 / E 120
50 $\leq$ $\varnothing$ $\leq$ 80 mm	-	EI 60 / E 120	EI 90 / E 120
All sheathed single core cables up to a diameter of 21 mm	-	EI 120	EI 120
Sheathed multi-core halogen free cables according to HD 604.5 up to a diameter of 50 mm	-	EI 90 / E120	EI 120
Single sheathed multi-core rubber cables according to HD 22.4 up to a diameter of 80 mm	-	EI 120	EI 120
Tied cable bundle <sup>6</sup> , maximum diameter of 100 mm, maximum diameter of single cable 21 mm	EI 60 / E 120	EI 60 / E 120	EI 120
Cable support construction: Perforated metal cable trays with a melting point higher than 1100°C (e.g. galvanised steel, stainless steel). Trays with organic coatings are covered if their overall classification is minimum A2 according to EN 13501-1.			
Minimum distance (mm): Cables/cable tray to seal edge ( $s_1$ ): 0 Cables to cable tray ( $s_2$ ): 50 Cables without tray: Cable to seal edge ( $s_1$ ): 0 Cable to cable ( $s_2$ ): 0 Cable to cable bundle ( $s_2$ ): 33			

Construction details

A) Cables on cable trays:

For explanation of abbreviations see the related text and Annex A

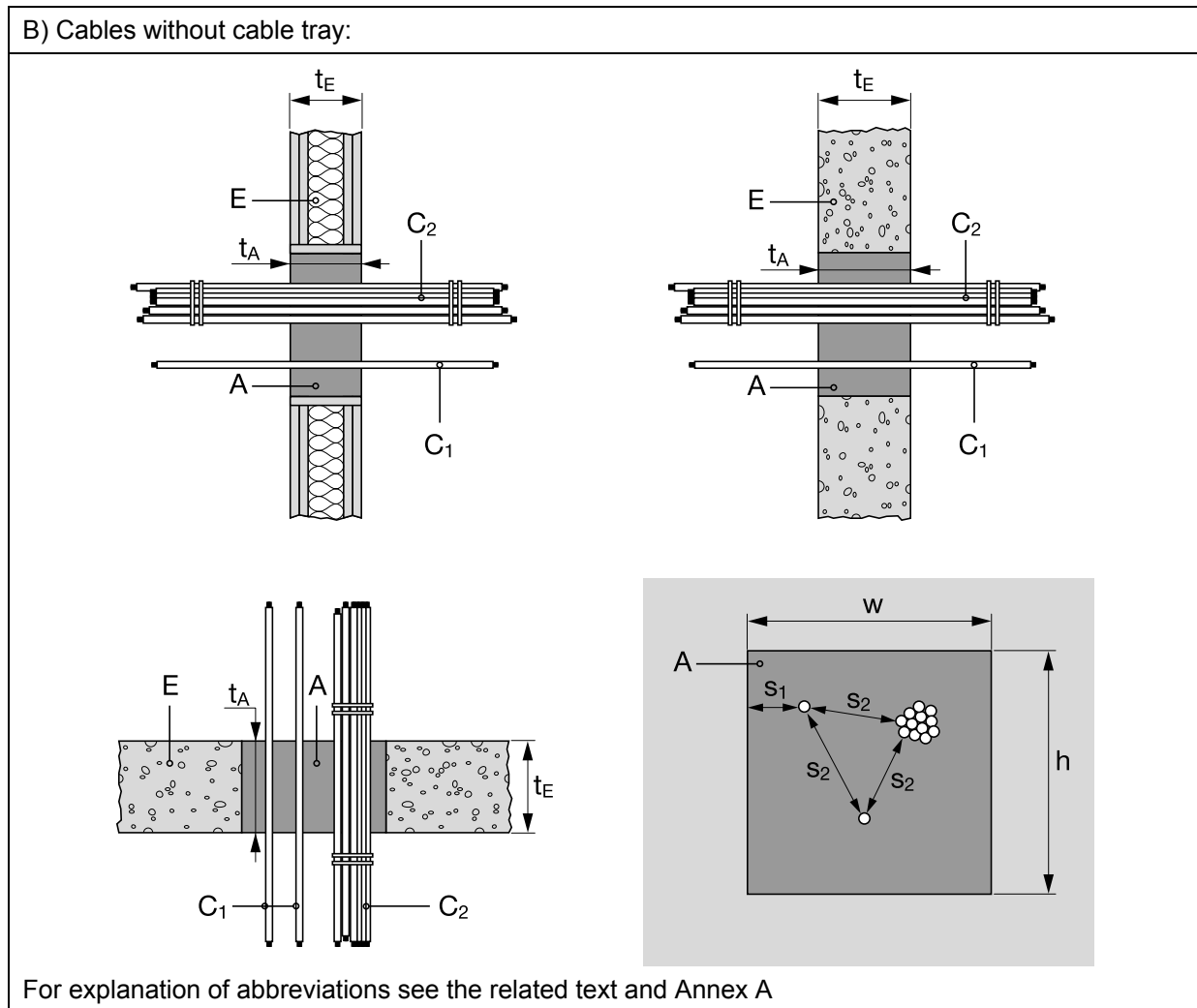

**Rigid floor constructions according to 1.2.1**

Penetration seal / Services	Classification	
<b>Hilti Firestop Foam CFS-F FX (A)</b> of thickness $t_A$ (mm) centered regarding the thickness of the building element (E). All sheathed cable types currently and commonly used in building practice in Europe (e.g. power, control, signal, telecommunication, data, optical fibre cables with a diameter of:	$150 \leq t_A \leq 250$	$t_A \geq 250$
Maximum $\varnothing$ 21 mm	EI 60 / E 120	EI 120
$21 \leq \varnothing \leq 50$ mm	EI 60 / E 120	EI 120
$50 \leq \varnothing \leq 80$ mm	EI 60 / E 120	EI 120
Tied cable bundle <sup>6</sup> , maximum diameter of 100 mm, maximum diameter of single cable 21 mm	EI 60 / E 120	EI 120
Cable support construction: Perforated metal cable trays with a melting point higher than 1100°C (e.g. galvanised steel, stainless steel). Trays with organic coatings are covered if their overall classification is minimum A2 according to EN 13501-1.		
Minimum distance (mm):		
Cables/cable tray to seal edge ( $s_1$ ):	0	
Cables to cable tray ( $s_2$ ):	50	
Cables without tray:		
Cable to seal edge ( $s_1$ ):	0	

Cable to cable ( $s_2$ ):	0
Cable to cable bundle ( $s_2$ ):	33
Construction details: see C.2.1	

## Conduits/tubes

### Flexible and rigid wall constructions according to 1.2.1

Penetration seal / Services	Classification		
<b>Hilti Firestop Foam CFS-F FX (A)</b> of thickness $t_A$ (mm) centered regarding the thickness of the building element (E).	$112 \leq t_A \leq 150$	$150 \leq t_A \leq 200$	$t_A \geq 200$
Steel conduits and tubes, $\varnothing$ maximum 16 mm	EI 90 U/U E 120 U/U	EI 90 U/U E 120 U/U	EI 120 U/U
The field of application given above is also valid for other metal conduits or tubes with lower heat conductivity than unalloyed steel and a melting point of minimum 1050°C, e.g. low alloyed steels, stainless steels, Ni alloys (NiCu, NiCr and NiMo alloys).			
Plastic conduits and tubes, $\varnothing$ maximum 16 mm	EI 120 U/U	EI 120 U/U	EI 120 U/U

### Rigid floor constructions according to 1.2.1

Penetration seal / Services	Classification
<b>Hilti Firestop Foam CFS-F FX (A)</b> of thickness $t_A \geq 150$ mm centered regarding the thickness of the building element (E).	
Steel conduits and tubes, $\varnothing$ maximum 16 mm	EI 120 U/U
The field of application given above is also valid for other metal conduits or tubes with lower heat conductivity than unalloyed steel and a melting point of minimum 1050°C, e.g. low alloyed steels, stainless steels, Ni alloys (NiCu, NiCr and NiMo alloys).	
Plastic conduits and tubes, $\varnothing$ maximum 16 mm	EI 120 U/U

### Metal pipes – Mineral wool insulation

Flexible wall, rigid wall and rigid floor constructions according to 1.2.1
<p><b>Penetration seal: Hilti Firestop Foam CFS-F FX (A) of thickness <math>t_A \geq 150</math> mm centered regarding the thickness of the building element (E).</b></p>
<p>Construction details:</p>
<p>A) Continued insulation</p>
<p>For explanation of abbreviations see the related text and Annex A</p>



B) Local insulation:

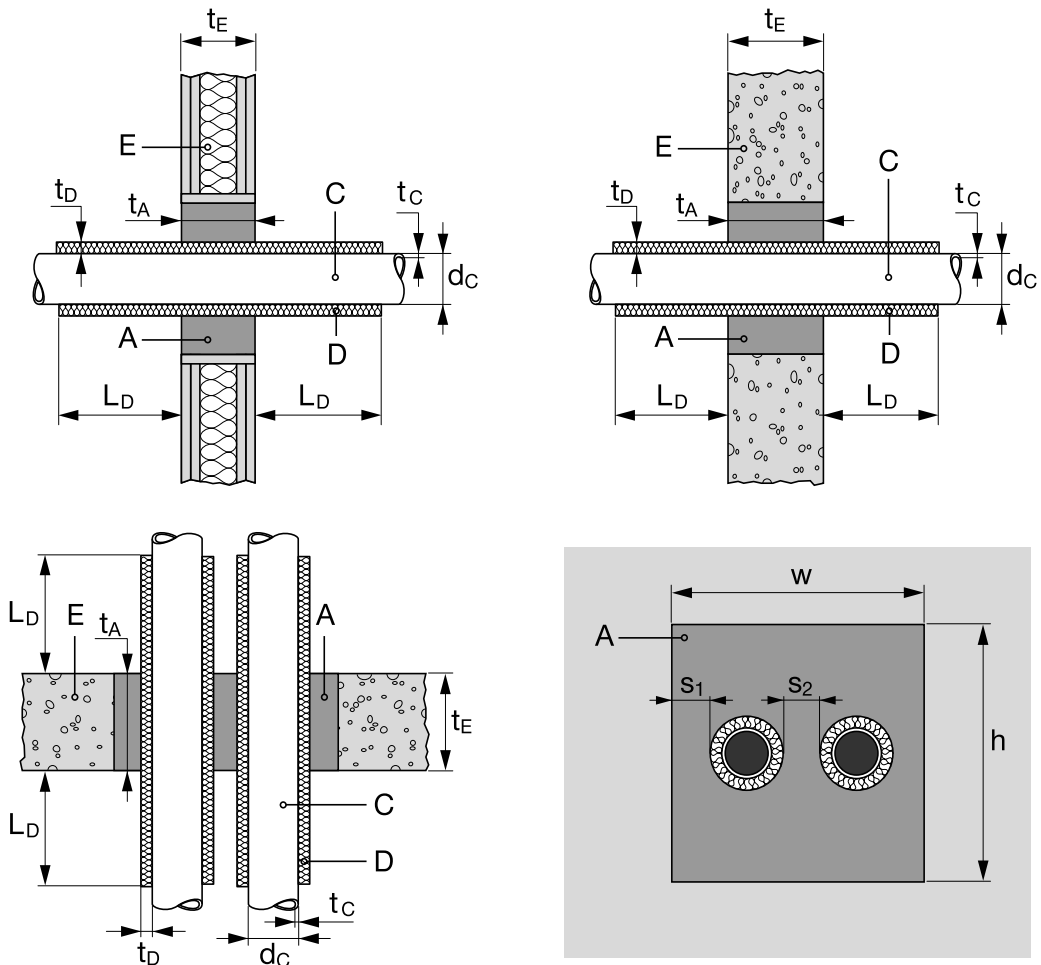

For explanation of abbreviations see the related text and Annex A

Minimum distance (mm):	wall	floor
between pipe and seal edge ( $s_1$ ):	0	20
between pipes ( $s_2$ ):		
– linear arrangement:	0	15
– in a cluster:	40	20

**Steel pipes**

Services	Classification	
	Wall	Floor
<b>Steel pipes (C)</b> arranged linear or in a cluster with sustained insulation (D) made from <b>Rockwool RS800</b> – continued or local (minimum length $L_D$ from seal surface on both sides: 500 mm).		
<b>Insulation thickness <math>t_D = 30</math> mm:</b> Diameter $\varnothing 33,7$ mm and minimum wall thickness 2,6 mm, maximum wall thickness 14,2 mm	EI 120 C/U	EI 120 C/U
<b>Insulation thickness <math>t_D = 40</math> mm:</b> Diameter between $\varnothing 33,7$ mm and $\varnothing 114,3$ mm, with minimum wall thickness 2,6 mm and 3,6 mm respectively, interpolation of minimum thickness between these diameters; maximum wall thickness 14,2 mm	EI 120 C/U	EI 120 C/U
<b>Insulation thickness <math>t_D = 40</math> mm:</b> Diameter between $\varnothing 114,3$ mm and $\varnothing 168$ mm, with minimum wall thickness 3,6 mm and 14 mm respectively, interpolation of minimum thickness between these diameters; maximum wall thickness 14,2 mm	-	EI 120 C/U

Wall:

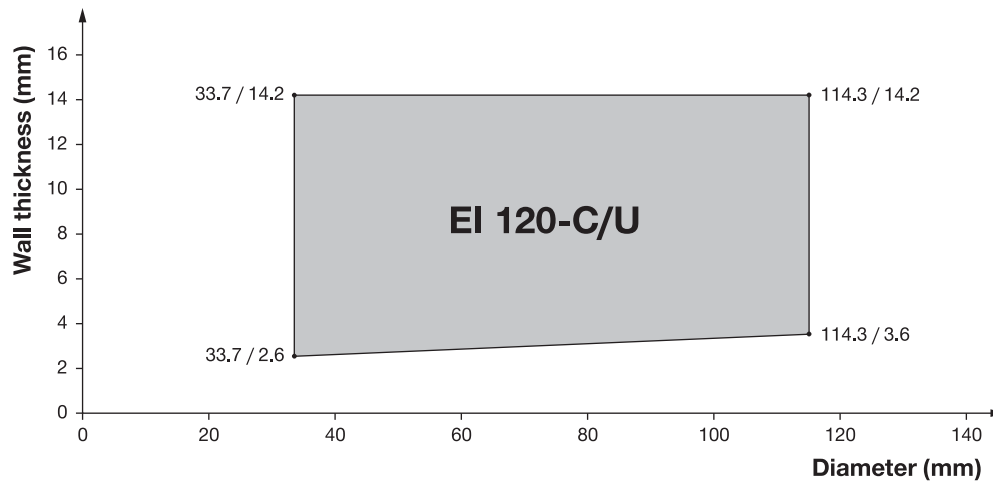

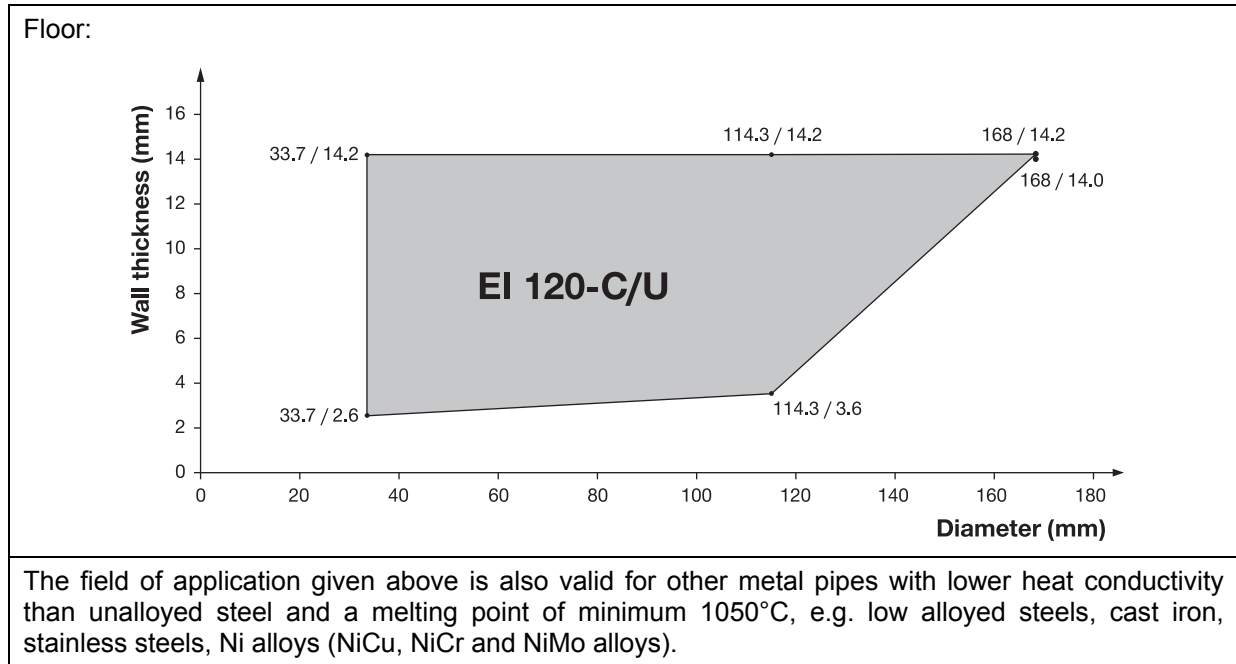

**Copper pipes**

Services	Classification	
	Wall	Floor
<b>Copper pipes</b> arranged linear or in a cluster with sustained insulation made from <b>Rockwool RS800</b> - continued or local (minimum length L <sub>D</sub> from seal surface on both sides: 500 mm).		
Diameter between Ø28 mm and Ø88,9 mm, with minimum wall thickness 1 mm and 2 mm respectively, interpolation of minimum thickness between these diameters; maximum wall thickness 14,2 mm	EI 60 C/U E 120 C/U	EI 120 C/U
Diameter Ø88,9 mm with minimum wall thickness 2 mm, maximum wall thickness 14,2 mm	EI 90 C/U E 120 C/U	-

The field of application given above is also valid for other metal pipes with lower heat conductivity than copper and a melting point of minimum 1050°C, e.g. unalloyed steels, low alloyed steels, cast iron, stainless steels, Ni and Ni alloys (NiCu, NiCr and NiMo alloys).

**Plastic pipes**

**Flexible wall, rigid wall and rigid floor constructions according to 1.2.1**

**Penetration seal: Hilti Firestop Foam CFS-F FX (A) of thickness  $t_A \geq 150$  mm centered regarding the thickness of the building element (E).**

Construction details:

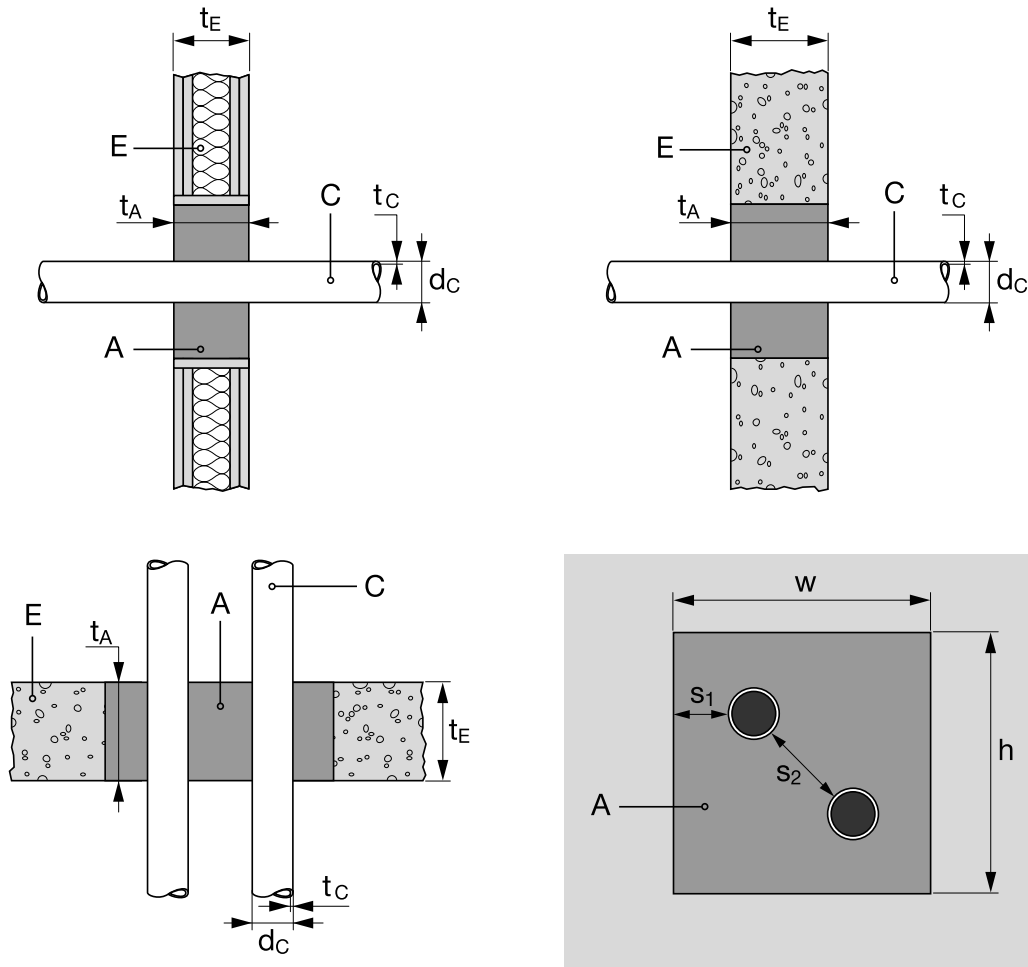

For explanation of abbreviations see the related text and Annex A

Minimum distance (mm):	<u>wall</u>	<u>floor</u>
between pipe and seal edge ( $s_1$ ):	30	50
between pipes ( $s_2$ ):	55	65

Services	Classification	
	Wall	Floor
<b>PE pipes (C)</b> according to EN 1519-1 and DIN 8074/8075 arranged linear, diameter $\varnothing 50$ mm with wall thickness between 2,9 mm and 4,6 mm.	EI 120 U/C	EI 120 U/C
<b>PVC-U pipes (C)</b> according to EN 1452-1 and DIN 8061/8062 arranged linear, diameter $\varnothing 50$ mm with wall thickness between 3,7 mm and 5,6 mm.	EI 120 U/C	EI 120 U/C
<b>PVC-U pipes</b> according to EN 1452-1 and DIN 8061/8062 arranged linear, diameter $\varnothing 50$ mm with wall thickness 3,7 mm.	-	EI 120 U/U

**ANNEX C**

**RESISTANCE TO FIRE CLASSIFICATION OF HILTI FIRESTOP FOAM CFS-F FX IN COMBINATION WITH HILTI FIRESTOP BANDAGE CFS-B**

**Metal pipes – Armaflex insulation**

<p><b>Flexible wall, rigid wall and rigid floor constructions according to 1.2.1</b></p>
<p><b>Penetration seal: Hilti Firestop Foam CFS-F FX (A) of thickness <math>t_A \geq 150</math> mm centered regarding the thickness of the building element (E). Services covered by two layers of Hilti Firestop Bandage CFS-B on both sides. The bandage is positioned with its centre line flush to the seal surface.</b></p>
<p>Construction details:</p>
<p>A) Continued insulation</p>
<p>For explanation of abbreviations see the related text and Annex A</p>

B) Local insulation:

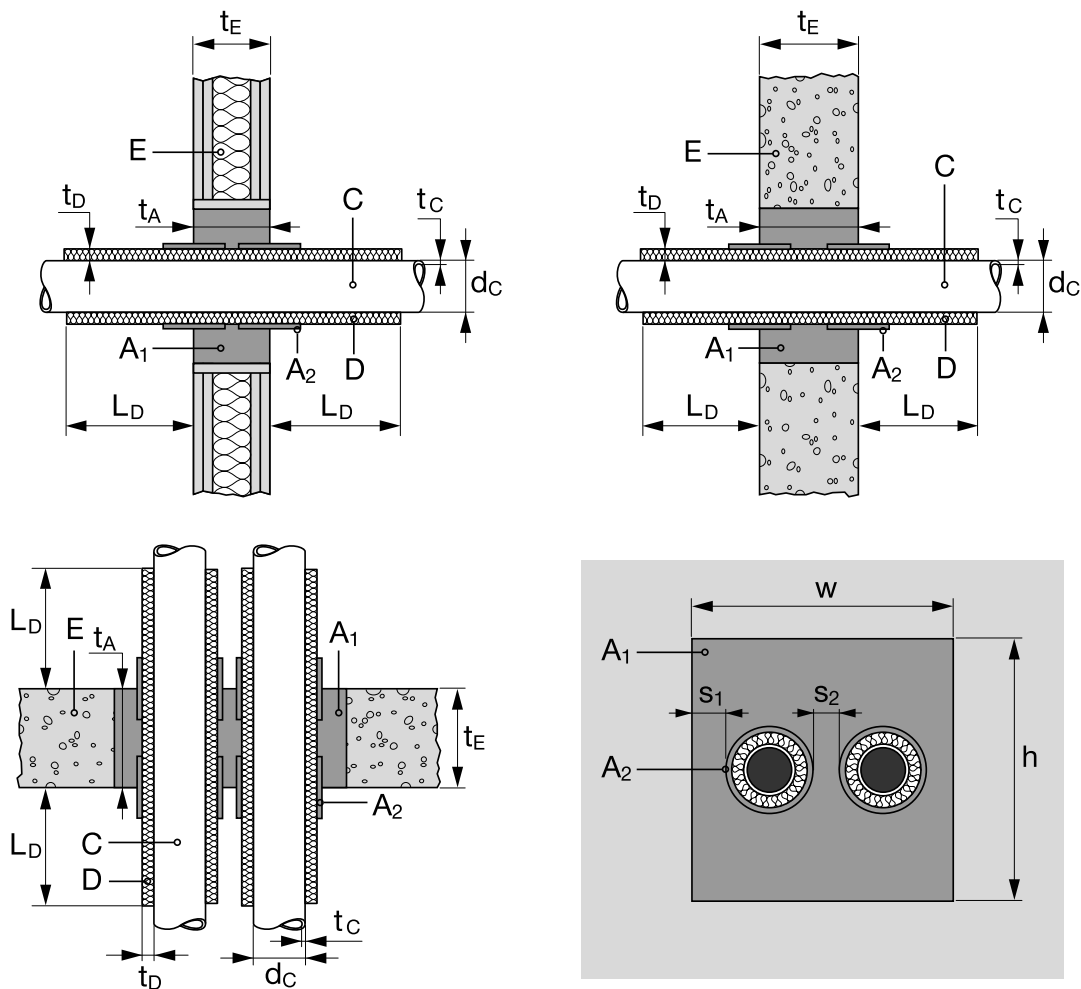

For explanation of abbreviations see the related text and Annex A

Minimum distance (mm):	<u>wall</u>	<u>floor</u>
between pipe and seal edge ( $s_1$ ):	15	40
between pipes ( $s_2$ ):	60	40

**Steel pipes**

Services	Classification	
	Wall	Floor
<b>Steel pipes</b> arranged linear or in a cluster with sustained insulation made from 19 mm <b>Armaflex AF19</b> - continued or local (minimum length $L_D$ from seal surface on both sides: 500 mm)		
Diameter between $\varnothing 33,7$ mm and $\varnothing 114,3$ mm, with minimum wall thickness 2,6 mm and 3,6 mm respectively, interpolation of minimum thickness between these diameters; interpolation of maximum wall thickness between 2,6 and 12,5 mm respectively.	EI 60-C/U E 120-C/U	EI 90-C/U E 120-C/U
Diameter between $\varnothing 33,7$ mm and $\varnothing 114,3$ mm, with minimum wall thickness 2,6 mm and 12,5 mm respectively, interpolation of minimum thickness between these diameters; maximum wall thickness 14,2 mm.	EI 90-C/U E 120-C/U	EI 120-C/U
Wall:		

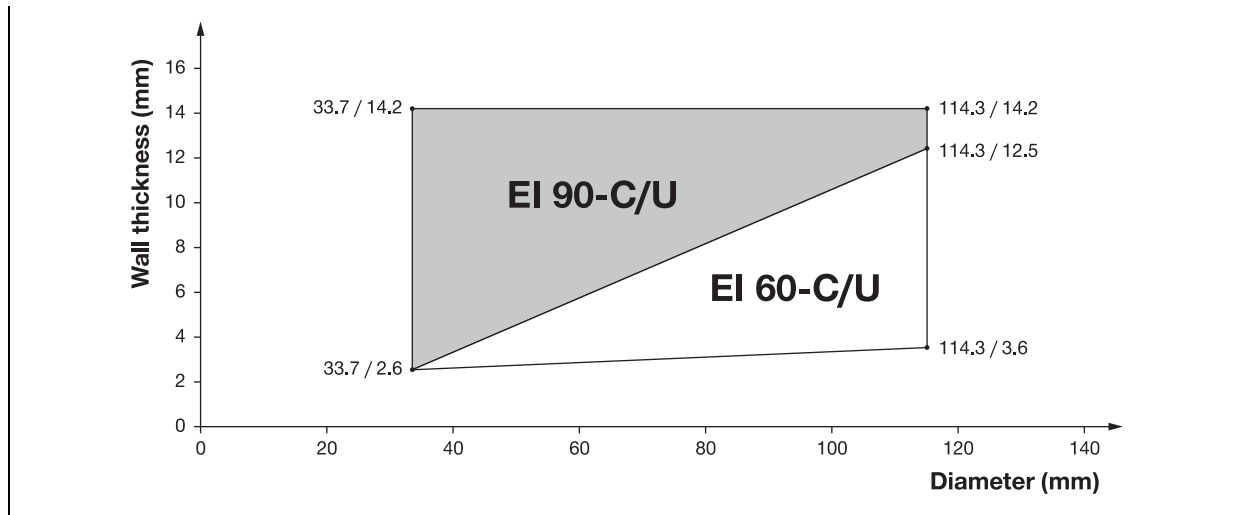

Floor:

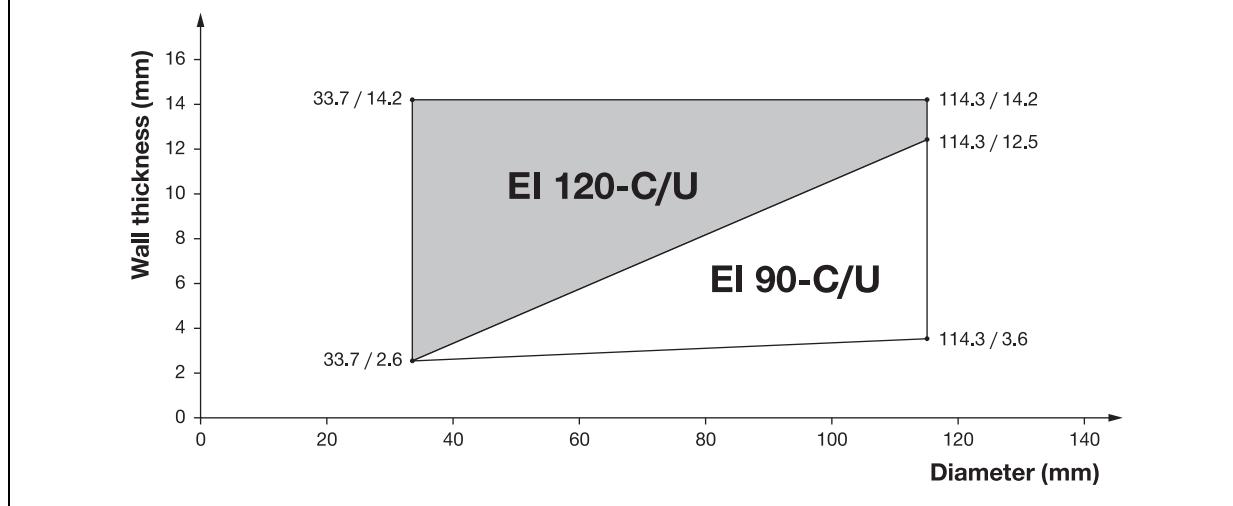

The field of application given above is also valid for other metal pipes with lower heat conductivity than unalloyed steel and a melting point of minimum 1050°C, e.g. low alloyed steels, cast iron, stainless steels, Ni alloys (NiCu, NiCr and NiMo alloys).

### Copper pipes

Services	Classification	
	Wall	Floor
<b>Copper pipes</b> arranged linear or in a cluster with sustained insulation made from 19 mm <b>Armaflex AF19</b> - continued or local (minimum length $L_D$ from seal surface on both sides: 500 mm).		
Diameter between Ø28 mm and Ø88,9 mm, with minimum wall thickness 1 mm and 2 mm respectively, interpolation of minimum thickness between these diameters; maximum wall thickness 14,2 mm	EI 60-C/U E 120-C/U	EI 90-C/U E 120-C/U
Diameter Ø28 mm with minimum wall thickness 1 mm, maximum wall thickness 14,2 mm	EI 120-C/U	EI 120-C/U
Wall:		

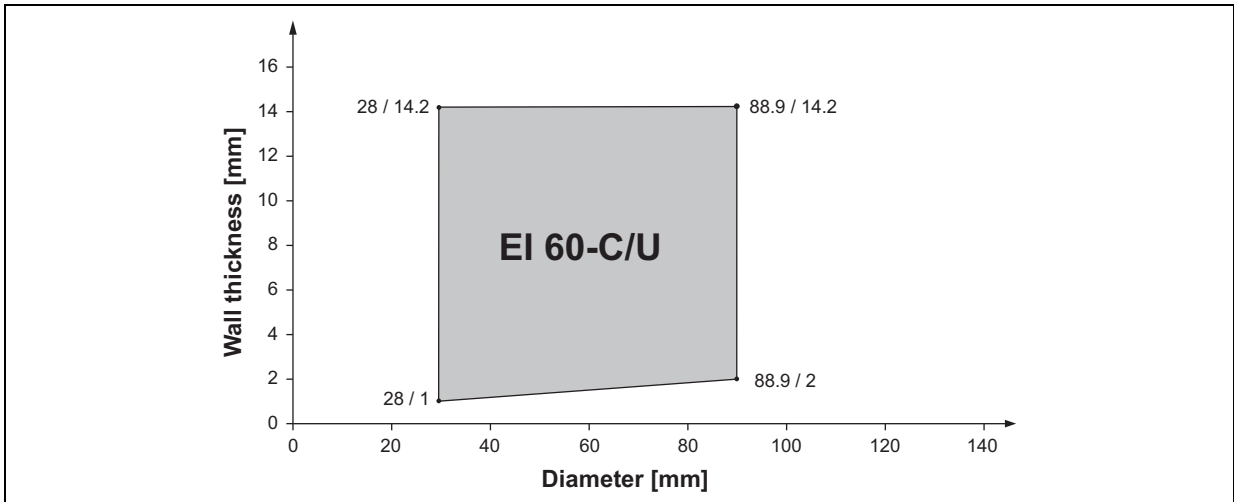

Floor:

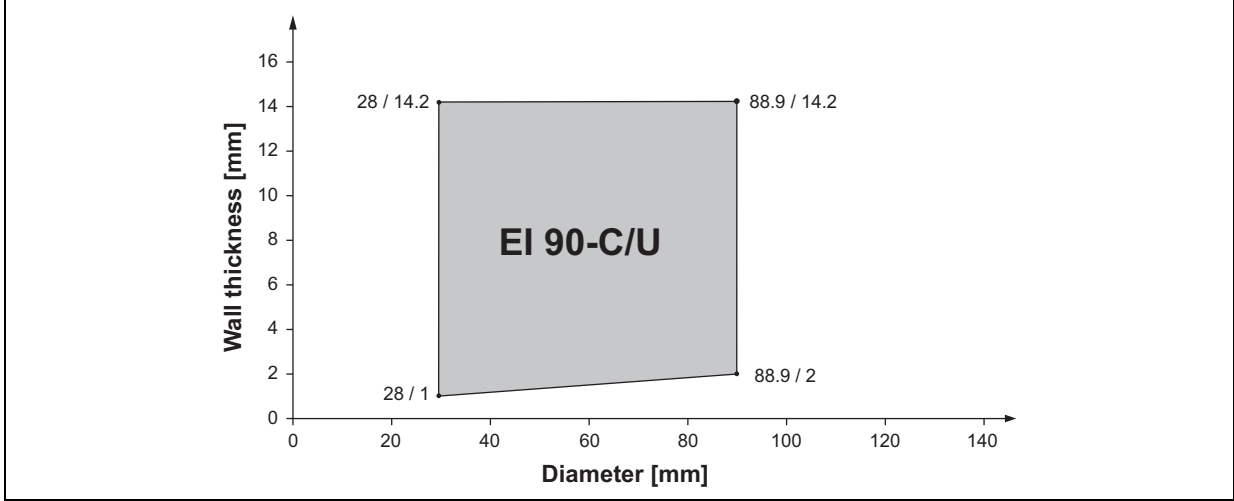

The field of application given above is also valid for other metal pipes with lower heat conductivity than copper and a melting point of minimum 1050°C, e.g. unalloyed steels, low alloyed steels, cast iron, stainless steels, Ni and Ni alloys (NiCu, NiCr and NiMo alloys).



**ANNEX D****RESISTANCE TO FIRE CLASSIFICATION FOR MIXED PENETRATION SEALS****Combination cables / metal pipes / plastic pipes****Flexible and rigid wall constructions according to 1.2.1**

Penetration seal / Services	Classification
<p><b>Hilti Firestop Foam CFS-F FX (A)</b> of thickness <math>t_A</math> (mm) centered regarding the thickness of the building element (E).</p> <p>Metal pipes with Armaflex insulation covered by two layers of <b>Hilti Firestop Bandage CFS-B</b> on both sides. The bandage is positioned with its centre line flush to the seal surface.</p>	<p><math>t_A \geq 150</math> mm</p>
<p><b>Cables / cable trays / small conduits/tubes:</b></p> <p>All <b>sheathed cable</b> types currently and commonly used in building practice in Europe (e.g. power, control, signal, telecommunication, data, optical fibre cables with a diameter up to 80 mm).</p> <p><b>Tied cable bundle</b> <sup>6)</sup>, maximum diameter of 100 mm, maximum diameter of single cable 21 mm.</p> <p>Cable support construction: Perforated <b>metal cable</b> trays with a melting point higher than 1100°C (e.g. galvanised steel, stainless steel). Trays with organic coatings are covered if their overall classification is minimum A2 according to EN 13501-1.</p> <p>Steel conduits and tubes or other metal conduits or tubes with lower heat conductivity than unalloyed steel and a melting point of minimum 1050°C, e.g. low alloyed steels, stainless steels, Ni alloys (NiCu, NiCr and NiMo alloys), Ø maximum 16 mm.</p>	<p>EI 60 / E 120</p>
<p><b>Metal pipes:</b></p> <p><b>Steel pipes (C)</b> or other metal pipes with lower heat conductivity than unalloyed steel and a melting point of minimum 1050°C, e.g. low alloyed steels, cast iron, stainless steels, Ni alloys (NiCu, NiCr and NiMo alloys) arranged linear or in a cluster with sustained insulation (D) made from 40 mm thick <b>Rockwool RS800</b> – continued or local (minimum length <math>L_D</math> from seal surface on both sides: 500 mm). Pipe diameter between Ø33,7 mm and Ø114,3 mm, with minimum wall thickness 2,6 mm and 3,6 mm respectively, interpolation of minimum thickness between these diameters; maximum wall thickness 14,2 mm.</p> <p><b>Copper pipes</b> or other metal pipes with lower heat conductivity than copper and a melting point of minimum 1050°C, e.g. unalloyed steels, low alloyed steels, cast iron, stainless steels, Ni and Ni alloys (NiCu, NiCr and NiMo alloys) arranged linear or in a cluster with sustained insulation made from 40 mm thick <b>Rockwool RS800</b> - continued or local (minimum length <math>L_D</math> from seal surface on both sides: 500 mm). Diameter between Ø28 mm and Ø88,9 mm, with minimum wall thickness 1 mm and 2 mm respectively, interpolation of minimum thickness between these diameters; maximum wall thickness 14,2 mm.</p> <p><b>Steel pipes</b> or other metal pipes with lower heat conductivity than unalloyed steel and a melting point of minimum 1050°C, e.g. low alloyed steels, cast iron, stainless steels, Ni alloys (NiCu, NiCr and NiMo alloys) arranged linear or in a cluster with sustained insulation made from 19 mm <b>Armaflex AF19</b> - continued or local (minimum length <math>L_D</math> from seal surface on both sides: 500 mm); Diameter between Ø33,7 mm and Ø114,3 mm, with minimum wall thickness 2,6 mm and 3,6 mm respectively, interpolation of minimum thickness between these diameters; maximum wall thickness 14,2 mm.</p>	<p>EI 60 C/U E 120 C/U</p>

<p><b>Copper pipes</b> or other metal pipes with lower heat conductivity than copper and a melting point of minimum 1050°C, e.g. unalloyed steels, low alloyed steels, cast iron, stainless steels, Ni and Ni alloys (NiCu, NiCr and NiMo alloys) arranged linear or in a cluster with sustained insulation made from 19 mm <b>Armaflex AF19</b> - continued or local (minimum length <math>L_D</math> from seal surface on both sides: 500 mm). Diameter between <math>\varnothing 28</math> mm and <math>\varnothing 88,9</math> mm, with minimum wall thickness 1 mm and 2 mm respectively, interpolation of minimum thickness between these diameters; maximum wall thickness 14,2 mm.</p>	<p>EI 60 C/U E 120 C/U</p>														
<p><b>Plastic pipes:</b> <b>PE pipes</b> (<math>C_4</math>) according to EN 1519-1 and DIN 8074/8075 arranged linear, diameter <math>\varnothing 50</math> mm with wall thickness between 2,9 mm and 4,6 mm. <b>PVC-U pipes</b> (C) according to EN 1452-1 and DIN 8061/8062 arranged linear, diameter <math>\varnothing 50</math> mm with wall thickness between 3,7 mm and 5,6 mm.</p>	<p>EI 60 U/C E 120 U/C</p>														
<p>Minimum distance (mm):</p> <table border="0"> <tr> <td>between cables/cable tray and seal edge (<math>s_1</math>):</td> <td>0</td> </tr> <tr> <td>between cables and cable tray above / cables and pipes (<math>s_2</math>):</td> <td>35</td> </tr> <tr> <td>between metal pipes and seal edge (<math>s_1</math>):</td> <td>0</td> </tr> <tr> <td>between metal pipes - linear arrangement (<math>s_2</math>):</td> <td>0</td> </tr> <tr> <td>between metal pipes - cluster arrangement (<math>s_2</math>):</td> <td>40</td> </tr> <tr> <td>between plastic pipes and seal edge (<math>s_1</math>):</td> <td>30</td> </tr> <tr> <td>between plastic pipes and between metal and plastic pipes (<math>s_2</math>):</td> <td>55</td> </tr> </table>		between cables/cable tray and seal edge ( $s_1$ ):	0	between cables and cable tray above / cables and pipes ( $s_2$ ):	35	between metal pipes and seal edge ( $s_1$ ):	0	between metal pipes - linear arrangement ( $s_2$ ):	0	between metal pipes - cluster arrangement ( $s_2$ ):	40	between plastic pipes and seal edge ( $s_1$ ):	30	between plastic pipes and between metal and plastic pipes ( $s_2$ ):	55
between cables/cable tray and seal edge ( $s_1$ ):	0														
between cables and cable tray above / cables and pipes ( $s_2$ ):	35														
between metal pipes and seal edge ( $s_1$ ):	0														
between metal pipes - linear arrangement ( $s_2$ ):	0														
between metal pipes - cluster arrangement ( $s_2$ ):	40														
between plastic pipes and seal edge ( $s_1$ ):	30														
between plastic pipes and between metal and plastic pipes ( $s_2$ ):	55														
<p>Construction details:</p>															
<p>A) Continued pipe insulation</p>															
<p>For explanation of abbreviations see the related text and Annex A</p>															

B) Local pipe insulation:

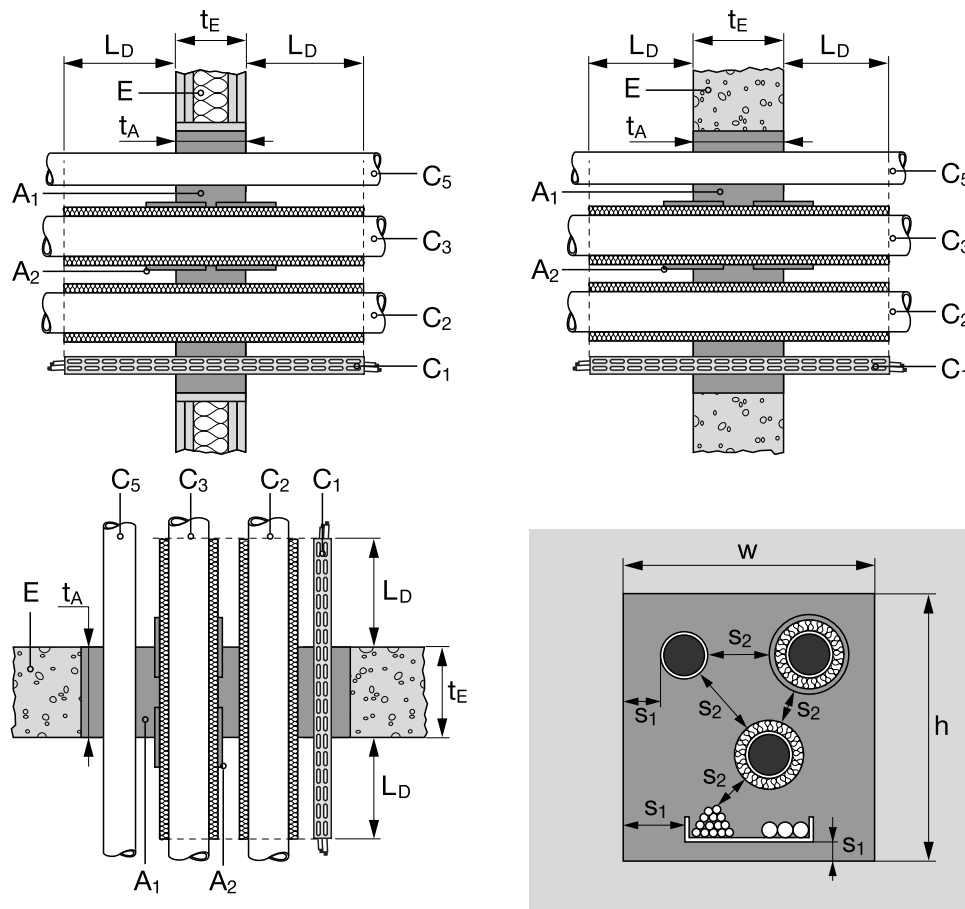

For explanation of abbreviations see the related text and Annex A

Rigid floor constructions according to 1.2.1

Penetration seal / Services	Classification
<p><b>Hilti Firestop Foam CFS-F FX (A)</b> of thickness <math>t_A</math> (mm) centered regarding the thickness of the building element (E).</p> <p>Metal pipes with Armaflex insulation covered by two layers of <b>Hilti Firestop Bandage CFS-B</b> on both sides. The bandage is positioned with its centre line flush to the seal surface.</p>	<p><math>t_A \geq 150</math> mm</p>
<p><b>Cables / cable trays / small conduits/tubes:</b></p> <p>All <b>sheathed cable</b> types currently and commonly used in building practice in Europe (e.g. power, control, signal, telecommunication, data, optical fibre cables with a diameter up to 80 mm).</p> <p><b>Tied cable bundle</b> <sup>6</sup>, maximum diameter of 100 mm, maximum diameter of single cable 21 mm.</p> <p>Cable support construction: Perforated <b>metal cable</b> trays with a melting point higher than 1100°C (e.g. galvanised steel, stainless steel). Trays with organic coatings are covered if their overall classification is minimum A2 according to EN 13501-1.</p> <p>Steel conduits and tubes or other metal conduits or tubes with lower heat conductivity than unalloyed steel and a melting point of minimum 1050°C, e.g. low alloyed steels, stainless steels, Ni alloys (NiCu, NiCr and NiMo alloys), Ø maximum 16 mm.</p>	<p>EI 60 / E 120</p>

<p><b>Metal pipes:</b></p> <p><b>Steel pipes</b> (C) or other metal pipes with lower heat conductivity than unalloyed steel and a melting point of minimum 1050°C, e.g. low alloyed steels, cast iron, stainless steels, Ni alloys (NiCu, NiCr and NiMo alloys) arranged linear or in a cluster with sustained insulation (D) made from 40 mm thick <b>Rockwool RS800</b> – continued or local (minimum length <math>L_D</math> from seal surface on both sides: 500 mm). Pipe diameter between Ø33,7 mm and Ø114,3 mm, with minimum wall thickness 2,6 mm and 3,6 mm respectively, interpolation of minimum thickness between these diameters; maximum wall thickness 14,2 mm.</p> <p><b>Copper pipes</b> or other metal pipes with lower heat conductivity than copper and a melting point of minimum 1050°C, e.g. unalloyed steels, low alloyed steels, cast iron, stainless steels, Ni and Ni alloys (NiCu, NiCr and NiMo alloys) arranged linear or in a cluster with sustained insulation made from 40 mm thick <b>Rockwool RS800</b> - continued or local (minimum length <math>L_D</math> from seal surface on both sides: 500 mm). Diameter between Ø28 mm and Ø88,9 mm, with minimum wall thickness 1 mm and 2 mm respectively, interpolation of minimum thickness between these diameters; maximum wall thickness 14,2 mm.</p> <p><b>Steel pipes</b> or other metal pipes with lower heat conductivity than unalloyed steel and a melting point of minimum 1050°C, e.g. low alloyed steels, cast iron, stainless steels, Ni alloys (NiCu, NiCr and NiMo alloys) arranged linear or in a cluster with sustained insulation made from 19 mm <b>Armaflex AF19</b> - continued or local (minimum length <math>L_D</math> from seal surface on both sides: 500 mm); Diameter between Ø33,7 mm and Ø114,3 mm, with minimum wall thickness 2,6 mm and 3,6 mm respectively, interpolation of minimum thickness between these diameters; maximum wall thickness 14,2 mm.</p> <p><b>Copper pipes</b> or other metal pipes with lower heat conductivity than copper and a melting point of minimum 1050°C, e.g. unalloyed steels, low alloyed steels, cast iron, stainless steels, Ni and Ni alloys (NiCu, NiCr and NiMo alloys) arranged linear or in a cluster with sustained insulation made from 19 mm <b>Armaflex AF19</b> - continued or local (minimum length <math>L_D</math> from seal surface on both sides: 500 mm). Diameter between Ø28 mm and Ø88,9 mm, with minimum wall thickness 1 mm and 2 mm respectively, interpolation of minimum thickness between these diameters; maximum wall thickness 14,2 mm.</p>	<p>EI 60 C/U E 120 C/U</p>														
<p><b>Plastic pipes:</b></p> <p><b>PE pipes</b> (C<sub>4</sub>) according to EN 1519-1 and DIN 8074/8075 arranged linear, diameter Ø50 mm with wall thickness between 2,9 mm and 4,6 mm.</p> <p><b>PVC-U pipes</b> (C) according to EN 1452-1 and DIN 8061/8062 arranged linear, diameter Ø50 mm with wall thickness between 3,7 mm and 5,6 mm.</p>	<p>EI 60 U/C E 120 U/C</p>														
<p>Minimum distance (mm):</p> <table> <tr> <td>between cables/cable tray and seal edge (<math>s_1</math>):</td> <td>0</td> </tr> <tr> <td>between cables and cable tray above / cables and pipes (<math>s_2</math>):</td> <td>35</td> </tr> <tr> <td>between metal pipes and seal edge (<math>s_1</math>):</td> <td>0</td> </tr> <tr> <td>between metal pipes - linear arrangement (<math>s_2</math>):</td> <td>0</td> </tr> <tr> <td>between metal pipes - cluster arrangement (<math>s_2</math>):</td> <td>40</td> </tr> <tr> <td>between plastic pipes and seal edge (<math>s_1</math>):</td> <td>30</td> </tr> <tr> <td>between plastic pipes and between metal and plastic pipes (<math>s_2</math>):</td> <td>55</td> </tr> </table>		between cables/cable tray and seal edge ( $s_1$ ):	0	between cables and cable tray above / cables and pipes ( $s_2$ ):	35	between metal pipes and seal edge ( $s_1$ ):	0	between metal pipes - linear arrangement ( $s_2$ ):	0	between metal pipes - cluster arrangement ( $s_2$ ):	40	between plastic pipes and seal edge ( $s_1$ ):	30	between plastic pipes and between metal and plastic pipes ( $s_2$ ):	55
between cables/cable tray and seal edge ( $s_1$ ):	0														
between cables and cable tray above / cables and pipes ( $s_2$ ):	35														
between metal pipes and seal edge ( $s_1$ ):	0														
between metal pipes - linear arrangement ( $s_2$ ):	0														
between metal pipes - cluster arrangement ( $s_2$ ):	40														
between plastic pipes and seal edge ( $s_1$ ):	30														
between plastic pipes and between metal and plastic pipes ( $s_2$ ):	55														
<p>Construction details: see E.1.1</p>															

**ANNEX E****INSTRUCTION FOR USE****Instructions for use**

Hilti Firestop Foam CFS-F FX is approved **as a permanent firestop seal for indoor applications.**

The foam can be used to form a firestop seal around cables, cable trays, combustible / non-combustible pipes passing through medium-sized openings in fire compartment walls and ceilings.

**National approval and fire prevention regulations take priority and must be observed.**

**Read these instructions and safety precautions before using the product.**

**Expiry date:** See date printed on the manifold (month/year). Use of the foil pack after this date is not permissible!

**Transport and storage:** Store in a cool, dry, dark place at a temperature of **+5°C to +25°C / +41°F to +77°F.**

**Foil pack temperature:** Must be between **+10°C and +35°C / +50°F and +97°F** during application.

**Base material temperature:** Must be between **0°C and +40°C / 32°F and +104°F** during application.

**Installation instructions:** The operations to be carried out are illustrated in pictograms 1- 9.

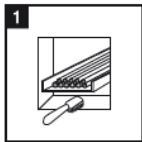

**Clean the opening to be sealed.** The material around the opening must be dry, in sound condition and free from dust or grease.

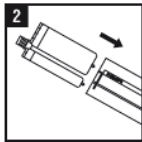

Check the foil pack holder for damage and ensure that it functions correctly. **Slide the foil pack into the holder.** **Caution:** Never use damaged foil packs and/or damaged or badly soiled foil pack holders.

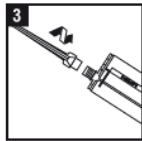

Remove the cap. **Screw the mixing nozzle all the way onto the foil pack and tighten it securely.** Check that the black mixing element is in place inside the nozzle! Do not use damaged mixing nozzles. Do not, under any circumstances, modify or tamper with the mixing nozzle. The foil pack should only be used together with the mixing nozzle supplied. A new mixing nozzle must be used with each new foil pack.

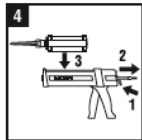

**Insert the holder containing the foil pack into the dispenser:** Press the release button on the dispenser, pull the piston rod back as far as it will go and then insert the holder containing the foil pack into the dispenser.

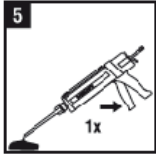

The foil pack opens automatically when dispensing begins. Never pierce a hole in the foil pack! This will cause the system to malfunction.

**Discard the unevenly mixed initial quantity:** The foam dispensed by the first stroke of the dispenser must be discarded, e.g. in the empty outer packaging material.

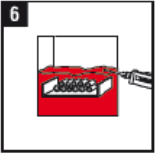

**Apply the firestop foam in the opening to be sealed.** The mixed components of the foam react and begin to expand approx. 30 seconds after application (at 23°C). Fill the opening completely with firestop foam, including gaps between individual cables, etc.

**- NOTE -**

It is generally best to begin in the middle of the opening, building up the foam by working from bottom to top. In openings with access from only one side, begin at the rear and work toward the front.

The foam will harden in the mixing nozzle during pauses (i.e. > 1 minute at 23°C; > 20 seconds at 35°C). **The mixing nozzle must then be changed.** Release the pressure from the piston rod before changing the mixing nozzle.

Use formwork made from an air-permeable material (e.g. perforated cardboard) when filling openings in ceilings.



The foam can be shaped or smoothed by hand (if necessary) after approx. 5 minutes (at 23°C).

**Wear protective gloves!** After approx. 10 minutes (at 23°C) the foam becomes hard and it can then be cut.

**- NOTE -**

After hardening, any projecting foam can be trimmed off to the specified minimum depth. Trimmed-off scraps of hardened foam can be placed in the next opening and fresh foam applied around these.

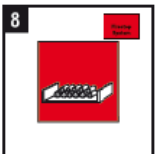

**Mount the installation identification plate beside the correctly sealed opening.**



#### **Subsequent installation of cables or pipes**

Additional cables or pipes can be installed in the opening without difficulty.

Do not exceed the approved maximum number and size of cables or pipes.

1. The cable or pipe may be pushed directly through the foam. Where necessary, use a suitable tool (screwdriver or drill bit, etc.) to make a hole in the foam before pushing the cable or pipe through. Do not damage existing cables.

2. Seal any remaining gaps carefully with Hilti Firestop Foam CFS-F FX