



Underwriters Laboratories, Inc.
to UL 2079 and CAN/ULC-S115

System No. HW-S-0133

HWS0133

ANSI/UL2079	CAN/ULC S115
Assembly Rating — 2 Hr	F Rating — 2 Hr
Joint Width - 3/4 In. Max	FT Rating — 2 Hr
L Rating at Ambient — Less than 1 CFM/Lin Ft	FH Rating — 2 Hr
L Rating at 400°F — Less than 1 CFM/Lin Ft	FTH Rating — 2 Hr
	Joint Width - 19 mm Max
	L Rating at Ambient — Less than 1.55 L/s/lin m
	L Rating at 204°C — Less than 1.55 L/s/lin m

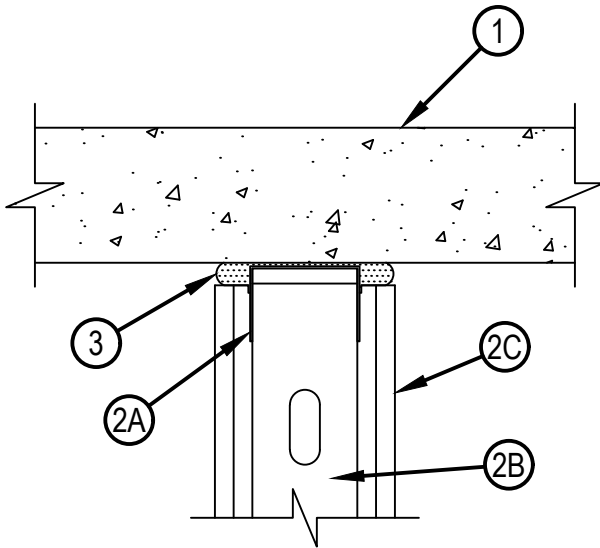

CONFIGURATION A

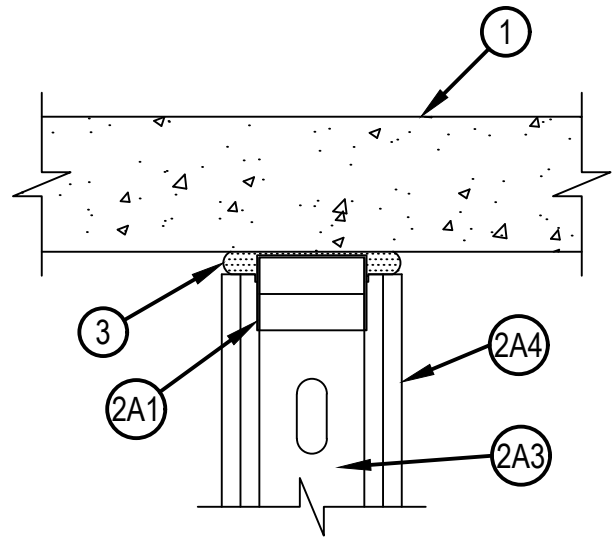

CONFIGURATION B



Reproduced by HILTI, Inc. Courtesy of
Underwriters Laboratories, Inc.
April 30, 2020

System No. HW-S-0133

HWS0133

1. Floor Assembly — Min 4-1/2 in. (114 mm) thick lightweight or normal weight (100 - 150 pcf or 1600-2400 kg/m³) concrete.
2. Wall Assembly — (Configuration A) The 2 hr fire rated gypsum board/steel stud wall assembly shall be constructed of the materials and in the manner described in the individual U400 Series Wall or Partition Design in the UL Fire Resistance Directory and shall include the following construction features:
 - A. Steel Floor And Ceiling Runners — Floor and ceiling runners of wall assembly shall consist of min 25 ga galv steel channels sized to accommodate steel studs (Item 2B). Runners to be provided with min 1 in. (25 mm) flanges. Ceiling runner is secured to floor with steel masonry anchors spaced a max of 24 in. (610 mm) OC.
 - A1. Light Gauge Framing* — Slotted Ceiling Runner — As an alternate to the ceiling runner in Item 2A, slotted ceiling runner to consist of min No. 20 gauge galv steel channel with slotted flanges having flange height of min 2 in. (51 mm) and sized to accommodate the steel studs (Item 2B). Slotted ceiling runner secured to concrete floor slab with steel masonry anchors or steel fasteners spaced max 24 in. (610 mm) OC.

BRADY CONSTRUCTION INNOVATIONS INC, DBA SLIPTRACK SYSTEMS — SLP-TRK
CALIFORNIA EXPANDED METAL PRODUCTS CO — CST
CLARKDIETRICH BUILDING SYSTEMS — Types SLT, SLT-H
MARINO/WARE, DIV OF WARE INDUSTRIES INC — Type SLT
METAL-LITE INC — The System
SCAFCO STEEL STUD MANUFACTURING CO — Slotted Track
TELLING INDUSTRIES L L C — True-Action Deflection Track

 - B. Studs — Steel studs to be min 2-1/2 in. (64 mm) wide. Studs attached to ceiling runner with sheet metal screws. Stud spacing not to exceed 24 in. (610 mm) OC.
 - C. Gypsum Board* — Gypsum board sheets installed to a min total thickness of 1-1/4 in. (32 mm) on each side of wall. Wall to be constructed as specified in the individual Wall and Partition Design in the UL Fire Resistance Directory, except that a max 3/4 in. (19 mm) gap shall be maintained between the top of the gypsum board and the lower surface of the floor.
- 2A. Wall Assembly — (Configuration B) The 2 hr fire rated gypsum board/wood stud wall assembly shall be constructed of the materials and in the manner described in the individual U300, V300 or W300 Series Wall or Partition Design in the UL Fire Resistance Directory and shall include the following construction features:
 - A1. Top Plate — The double top plate shall consist of two 2 by 4 in. (51 by 102 mm) lumber plates, tightly butted. First lumber plate secured to concrete floor with Hilti X-C P8S 2-27/32 in. (72 mm) long concrete nails spaced max 24 in. (610 mm) OC. Second lumber plate secured to first lumber plate with min 2-1/2 in. (64 mm) long wood screws spaced max 24 in. (610 mm) OC. Joints in lumber plates staggered.
 - A2. Sole Plate — (Not Shown) Nom 2 by 4 in. (51 by 102 mm) lumber plate.
 - A3. Wood Studs — Nom 2 by 4 in. (51 by 102 mm) lumber studs spaced 16 in. (406 mm) OC max.
 - A4. Gypsum Board* — Gypsum board sheets installed to a min total thickness of 1-1/4 in. (32 mm) on each side of wall. Wall to be constructed as specified in the individual Wall and Partition Design in the UL Fire Resistance Directory, except that a max 3/4 in. (19 mm) gap shall be maintained between the top of the gypsum board and the lower surface of the floor.
3. Fill, Void or Cavity Material* - Top Track Seal — Factory supplied foam seal cut in half lengthwise at dotted line or tear strip, and the halves then folded and pushed into the joint to be friction fit and to be flush against the ceiling runner or top plate at each side of wall. The butt joints in the Top Track Seal shall be compressed together by min 1/4 in. (6 mm) and spaced min 36 in. (914 mm) apart along length of joint. Butt joints shall be offset min 12 in. (305 mm) on opposite sides of wall.
HILTI CONSTRUCTION CHEMICALS, DIV OF HILTI INC — CFS-TTS 212, CFS-TTS 358, CFS-TTS 600, CFS-TTS R or CFS-TTS-OS

* Indicates such products shall bear the UL or cUL Certification Mark for jurisdictions employing the UL or cUL Certification (such as Canada), respectively.