



Classified by
Underwriters Laboratories, Inc.
to UL 2079 and CAN/ULC-S115

System No. HW-D-0934

HWD 0934

| ANSI/UL2079 | CAN/ULC S115 |
|--|--|
| Assembly Rating — 1 and 2 Hr (See Item 2) | F Rating — 1 and 2 Hr (See Item 2) |
| Nominal Joint Width - 1 In or 1-1/2 In (See Item 3) | FT Rating — 1 and 2 Hr (See Item 2) |
| Class II or III Movement Capabilities — 50% Compression or Extension or 66% Compression only | FH Rating — 1 and 2 Hr (See Item 2) |
| L Rating at Ambient - Less than 1 CFM/Lin ft | FTH Rating — 1 and 2 Hr (See Item 2) |
| L Rating at 400°F - Less than 1 CFM/Lin ft | Nominal Joint Width - 25 mm or 38mm (See Item 3) |
| | Class II or III Movement Capabilities — 50% Compression or Extension or 66% Compression only |
| | L Rating at Ambient - Less than 1.55 L/s/m |
| | L Rating at 204°C - Less than 1.55 L/s/m |

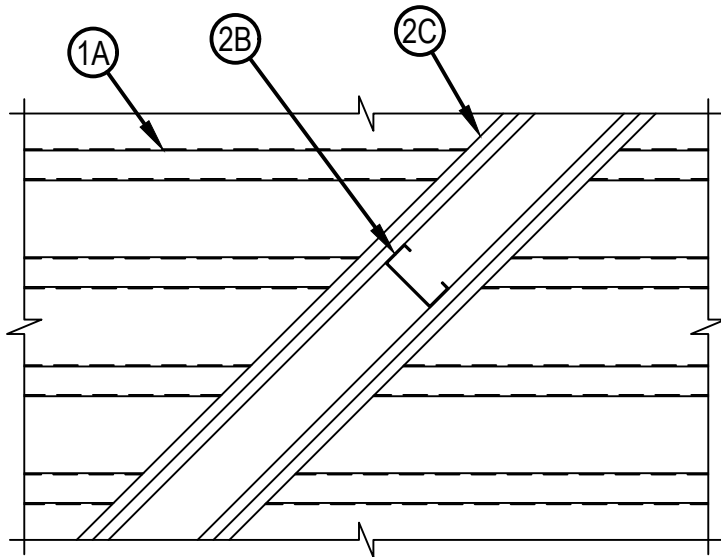

BOTTOM VIEW

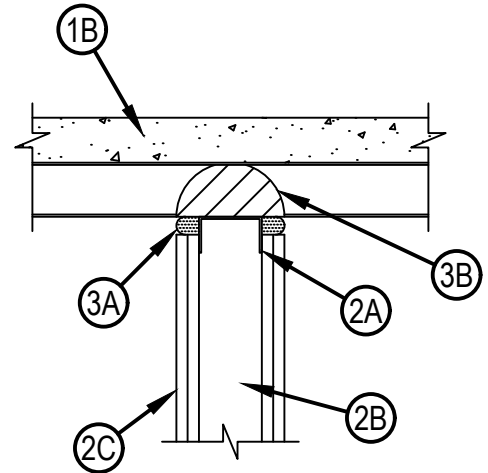

1. Floor Assembly — The fire-rated fluted steel deck/concrete floor assembly shall be constructed of the materials and in the manner described in the individual D900 Floor-Ceiling Design in the UL Fire Resistance Directory. The hourly fire rating of the floor assembly shall be equal to or greater than the hourly fire rating of the wall assembly. The floor assembly shall include the following construction features:

- A. Steel Floor And Form Units* — Composite max 4 in. (102 mm) deep galv steel fluted units.
EPIC METALS CORP — Types “EC” or “Toris C”
- A1. Steel Floor And Form Units* — Composite max 2 in. (51 mm) and max 3.5 in. (89 mm) deep galv steel fluted units.
NEW MILLENNIUM BUILDING SYSTEMS L L C — Versa-Dek®, Versa-Dek® 3.5VLSC
- B. Concrete — Min 2-1/2 in. (64 mm) thick reinforced (100-150 pcf or 1600-2400 kg/m³) concrete, as measured from the top plane of the floor units.

1A. Roof Assembly — (Not Shown) — As an alternate to the floor assembly, a fire rated fluted steel deck roof assembly may be used. The roof assembly shall be constructed of the materials and in the manner described in the individual P900 Series Roof-Ceiling Design in the UL Fire Resistance Directory. The hourly rating of the roof assembly shall be equal to or greater than the hourly rating of the wall assembly. The roof assembly shall include the following construction features:

- A. Steel Floor And Form Units* — Composite max 4 in. (102 mm) deep galv steel fluted units.
EPIC METALS CORP — Types “Toris C” or “ER2R”



Hilti Firestop Systems

Reproduced by HILTI, Inc. Courtesy of
Underwriters Laboratories, Inc.
August 27, 2021

System No. HW-D-0934

HWD 0934

- A1. Steel Floor And Form Units* — Composite max 2 in. (51 mm) and max 3.5 in. (89 mm) deep galv steel fluted units.
NEW MILLENNIUM BUILDING SYSTEMS L L C — Versa-Dek®, Versa-Dek® 3.5VLSC
- B. Roof Insulation — Min 2-1/2 in. (64 mm) thick poured insulating concrete, as measured from the top plane of the floor units.
2. Wall Assembly — The 1 or 2 h fire-rated gypsum board /steel stud wall assembly shall be constructed of the materials and in the manner specified in the individual U400, V400 or W400 Series Wall and Partition Design in the UL Fire Resistance Directory and shall include the following construction features:
- A. Steel Floor and Ceiling Runners — Floor and ceiling runners of wall assembly shall consist of min No. 25 gauge galv steel channels sized to accommodate steel studs (Item 2B). Flange height of ceiling runner shall be min 1 in. (25.4 mm) greater than max extended joint width. Ceiling runner installed at an angular traverse of the fluted steel deck and secured to valleys with steel masonry anchors or steel fasteners spaced max 24 in. (610 mm) OC.
- A1. Light Gauge Framing* — Slotted Ceiling Runner — As an alternate to Item 1, slotted ceiling runner to consist of galv steel channel with slotted flanges sized to accommodate steel studs (Item 2B). Flange height of slotted ceiling runner shall be min 1 in. (25.4 mm) greater than max extended joint width. Slotted ceiling runner installed at an angular traverse of the fluted steel deck and secured to valleys with steel masonry anchors, steel fasteners or welds spaced max 24 in. (610 mm) OC.
BRADY CONSTRUCTION INNOVATIONS INC, DBA SLIPTRACK SYSTEMS — SLP-TRK 325
CALIFORNIA EXPANDED METAL PRODUCTS CO — CST 325
CLARKDIETRICH BUILDING SYSTEMS — Types SLT, SLT-H
MARINO/WARE, DIV OF WARE INDUSTRIES INC — Type SLT
METAL-LITE INC — The System
SCAFCO STEEL STUD MANUFACTURING CO — Slotted Track
TELLING INDUSTRIES L L C — True-Action Slotted Track
- B. Studs — Steel studs to be min 3-5/8 in. (92 mm) wide. Studs cut 3/4 to 1 in. (19 to 25 mm) less in length than assembly height with bottom nesting in and resting on floor runner and with top nesting in ceiling runner without attachment. When slotted ceiling runner (Item 2A1) is used, steel stud secured to slotted ceiling runner with No. 8 by 1/2 in. (13 mm) long wafer head steel screws at mid-height of slot on each side of wall. Stud spacing not to exceed 24 in. (610 mm) OC.
- C. Gypsum Board* — For 1 hr assembly, one layer of 5/8 in (16mm) thick gypsum board is required in the individual Wall and Partition Design. For 2 hr assembly, two layers of 5/8 in. (16 mm) thick gypsum board is required in the individual Wall and Partition Design. The screws attaching the gypsum board to studs at the top of the wall shall be located 3-1/2 in. (89 mm) to 5-1/2 in. (138 mm) below the bottom edge of the ceiling runner.
The hourly ratings are equal to the hourly rating of the wall assembly.
3. Joint System — Max separation between the bottom of steel floor unit and top of wall is 1 in. (25 mm). The joint system is designed to accommodate a max 50 percent compression or extension from its installed width. When max separation between the bottom of steel floor unit and top of wall is 1-1/2 in. (38 mm), the joint system is designed to accommodate a max 66% compression only from its installed width. The joint system consists of the following:
- A. Fill, Void or Cavity Material* — Top Track Seal — Factory supplied foam seal installed over the ceiling runner (Item 2A) prior to attachment to the floor assembly in accordance with the installation instructions.
HILTI CONSTRUCTION CHEMICALS, DIV OF HILTI INC — CFS-TTS MD OS or CFS-TTS MD 600 Firestop Top Track Seal
- B. Fill, Void or Cavity Material* — Foam — The fluted areas of the composite steel floor deck above the wall to be filled continuously with foam. The foam is to extend at least flush with outer surface of the top track seal on both sides of the wall. In 2 hr rated walls, foam to be installed flush with bottoms of flutes; and foam may be gradually recessed in from face of wall by max 1/2 to 1 in. (13 to 25 mm) as it rises to the top of the flutes.
HILTI CONSTRUCTION CHEMICALS, DIV OF HILTI INC — CP 620 Fire Foam

* Indicates such products shall bear the UL or cUL Certification Mark for jurisdictions employing the UL or cUL Certification (such as Canada), respectively.



Hilti Firestop Systems

Reproduced by HILTI, Inc. Courtesy of
Underwriters Laboratories, Inc.
August 27, 2021

Page: 2 of 2