



Classified by
Underwriters Laboratories, Inc.
to UL 2079 and CAN/ULC-S115

System No. HW-D-0906

HW-D-0906

ANSI/UL2079	CAN/ULC S115
Assembly Ratings — 1 and 2 Hr (See Item 2)	F Ratings — 1 and 2 Hr (See Item 2)
Nominal Joint Width — 3/4 In.	FT Ratings — 1 and 2 Hr (See Item 2)
Class II Movement Capabilities — 33% Compression or Extension	FH Ratings — 1 and 2 Hr (See Item 2)
L Rating at Ambient — 2.1 CFM/Lin Ft	FTH Ratings — 1 and 2 Hr (See Item 2)
L Rating at 400° F — 1.9 CFM/Lin Ft	Nominal Joint Width — 19 mm
	Class II Movement Capabilities — 33% Compression or Extension
	L Rating at Ambient — 3.3 L/s/Lin m
	L Rating at 204°C — 2.9 L/s/Lin m

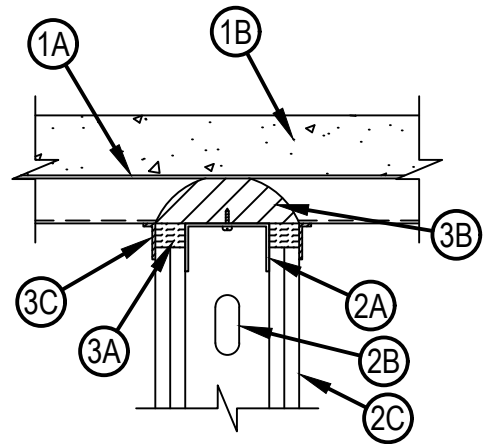
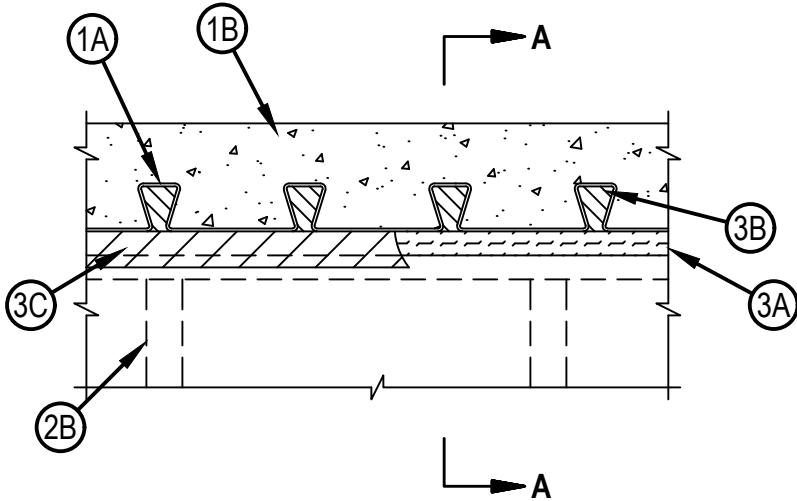

SECTION A-A



Reproduced by HILTI, Inc. Courtesy of
Underwriters Laboratories, Inc.
June 23, 2023

System No. HW-D-0906

HW-D-0906

1. Floor Assembly — The fire-rated fluted steel deck/concrete floor assembly shall be constructed of the materials and in the manner described in the individual D700 or D900 Series Floor-Ceiling Design in the UL Fire Resistance Directory and shall include the following construction features:
 - A. Steel Floor And Form Units* — Composite max 4 in. (102 mm) deep galv steel fluted units.
EPIC METALS CORP — Types EC, EC3.5, Toris C and Toris 4C
A1. Steel Floor And Form Units* — Composite max 2 in. (51 mm) and max 3.5 in. (89 mm) deep galv steel fluted units.
NEW MILLENNIUM BUILDING SYSTEMS L L C — Versa-Dek® 3.5VLSC
 - B. Concrete — Min 2-1/2 in. (64 mm) thick reinforced concrete, as measured from the top plane of the floor units.
 - 1A. Roof Assembly — (Not Shown) — As an alternate to the floor assembly, a fire rated fluted steel deck roof assembly may be used. The roof assembly shall be constructed of the materials and in the manner described in the individual P900 Series Roof-Ceiling Design in the UL Fire Resistance Directory. The hourly rating of the roof assembly shall be equal to or greater than the hourly rating of the wall assembly. The roof assembly shall include the following construction features:
 - A. Steel Floor And Form Units* — Composite max 4 in. (102 mm) deep galv steel fluted units.
EPIC METALS CORP — Types EC, EC3.5, Toris C and Toris 4C
A1. Steel Floor And Form Units* — Composite max 2 in. (51 mm) and max 3.5 in. (89 mm) deep galv steel fluted units.
NEW MILLENNIUM BUILDING SYSTEMS L L C — Versa-Dek®, Versa-Dek® 3.5VLSC
 - B. Roof Insulation — Min 2-1/2 in. (64 mm) thick poured insulating concrete, as measured from the top plane of the floor units.
2. Wall Assembly — The 1 or 2 hr fire rated gypsum board /steel stud wall assembly shall be constructed of the materials and in the manner described in the individual U400, V400 or W400 Series Wall and Partition Design in the UL Fire Resistance Directory and shall include the following construction features:
 - A. Steel Floor And Ceiling Runners — Floor and ceiling runners of wall assembly shall consist of min 25 ga galv steel channels sized to accommodate steel studs (Item 2C). Flange height of ceiling runner shall be min 1/4 in. (6 mm) greater than max extended joint width. Ceiling runner installed perpendicular to direction of fluted steel deck and secured with steel masonry anchors, steel fasteners or welds spaced max 24 in. (610 mm) OC.
 - A1. Light Gauge Framing* — Slotted Ceiling Runner — As an alternate to the ceiling runner in Item 2A, slotted ceiling runner to consist of min 20 ga galv steel channel with min 2-1/2 in. (64 mm) slotted flanges to accommodate steel studs (Item 2C). Slotted ceiling runner installed perpendicular to direction of fluted steel deck and secured with steel masonry anchors, steel fasteners or welds spaced max 24 in. (610 mm) OC.
BRADY CONSTRUCTION INNOVATIONS INC, DBA SLIPTRACK SYSTEMS — SLP-TRK
CEMCO, LLC — CST
CLARKDIETRICH BUILDING SYSTEMS — Type SLT, SLT-H
MARINO/WARE, DIV OF WARE INDUSTRIES INC — Type SLT
METAL-LITE INC — The System
RAM SALES L L C — RAM Slotted Track
SCAFCO STEEL STUD MANUFACTURING CO
STEELE INC — Steeler Slotted Ceiling Runner
TELLING INDUSTRIES L L C — True-Action Deflection TrackThe hourly rating of the joint system is dependent on the hourly rating of the wall.
 - B. Studs — Steel studs to be min 3-5/8 in. (92 mm) wide. Studs cut 1/2 to 3/4 in. (13 to 19 mm) less in length than assembly height with bottom nesting in and resting on floor runner and with top nesting in ceiling runner without attachment. When slotted ceiling runner (Item 2A1) is used, steel studs secured to slotted ceiling runner with No. 8 by 1/2 in. (13 mm) long wafer head steel screws at midheight of slot on each side of wall. Stud spacing not to exceed 24 in. (610 mm) OC. Stud spacing not to exceed 24 in. (610 mm) OC.
 - C. Gypsum Board* — Gypsum board installed to a min total thickness of 5/8 in. or 1-1/4 in. (16 or 32 mm) on each side of wall, for 1 and 2 hr rated walls respectively. Wall to be constructed as specified in the individual Wall and Partition Design in the UL Fire Resistance Directory, except that a nom 3/4 in. (19 mm) gap shall be maintained between the top of the gypsum board and the bottom of the steel floor units and the top row of screws shall be installed into the studs max 5-3/4 in. or 146 mm (outer layer) and max 7 in. or 178 mm (inner layer) below the bottom of the fluted deck.



Hilti Firestop Systems

Reproduced by HILTI, Inc. Courtesy of
Underwriters Laboratories, Inc.
June 23, 2023

Page: 2 of 3

3. Joint System — Max separation between bottom of floor and top of wall at time of installation of joint system is 3/4 in. (19 mm). The joint system is designed to accommodate a max 33 percent compression or extension from its installed width. The joint system consists of forming material and a fill material, as follows:
- A. Forming Material* — Nom 5/8 in. (16 mm) or 1-1/4 in. (32 mm) wide strips of min 4 pcf (64 kg/m³) mineral wool batt insulation, for 1 or 2 hr rated walls respectively, cut to a thickness twice the width of the joint and firmly packed with min 50 percent compression into the gap between the top of the gypsum board and bottom of the steel floor units on both sides of the wall. Pieces of mineral wool shall be packed to the maximum depth possible to fill any embossments within the valleys of the fluted deck.
INDUSTRIAL INSULATION GROUP L L C — MinWool-1200 Safing
ROCKWOOL — SAFE
THERMAFIBER INC — Type SAF
 - A1. Forming Material* — Strips — (Optional) — Nom 5/8 in. (16 mm) or 1-1/4 in. (32 mm) wide precut mineral wool strips, for 1 or 2 hr rated walls respectively. The strips are compressed 50 percent in thickness and firmly packed into the gap between the top of the gypsum board and bottom of the steel floor units on both sides of the wall.
HILTI CONSTRUCTION CHEMICALS, DIV OF HILTI INC — CP 767 Speed Strips
 - B. Fill, Void or Cavity Material* — Fill material installed to fill flutes above wall assembly. In 1 hr rated walls, foam to be installed flush with wall surfaces at both sides of wall. In 2 hr rated walls, foam to be installed flush with bottoms of flutes; and foam may be gradually recessed in from face of wall by max 1/2 to 1 in. (13 to 25 mm) as it rises to the top of the flutes.
HILTI CONSTRUCTION CHEMICALS, DIV OF HILTI INC — CP 620 Fire Foam
 - C. Fill, Void or Cavity Material* — Min 1/16 in. (1.6 mm) dry thickness (min 1/8 in. or 3.2 mm wet thickness) of fill material sprayed or troweled on each side of the wall to completely cover mineral wool forming material (Item 3A) and to overlap a min of 1/2 in. (13 mm) onto gypsum board and steel deck on both sides of wall. No fill material is required in the flutes of the deck.
HILTI CONSTRUCTION CHEMICALS, DIV OF HILTI INC — CFS-SP WB Firestop Joint Spray

* Indicates such products shall bear the UL or cUL Certification Mark for jurisdictions employing the UL or cUL Certification (such as Canada), respectively.

