



Classified by
Underwriters Laboratories, Inc.
to UL 1479 and CAN/ULC-S115

System No. W-J-3189

W-J-3189

ANSI/UL1479 (ASTM E814)	CAN/ULC S115
F Rating - 2 Hr	F Rating - 2 Hr
T Ratings - 1/2 and 1-1/2 Hr (See Item 2)	FT Ratings - 1/2 and 1-1/2 Hr (See Item 2)
L Rating At Ambient - 1.2 and Less Than 1 CFM per Device (See Items 2, 3A and 3A1)	FH Rating - 2 Hr
L Ratings At 400 F - 1.3, 1.6 and Less Than 1 CFM per Device (See Items 2, 3A and 3A1)	FTH Ratings - 1/2 and 1-1/2 Hr (See Item 2)
	L Rating At Ambient - 0.6 and Less Than 0.5 L/s per Device (See Items 2, 3A and 3A1)
	L Ratings At 204°C - 0.6, 0.8 and Less Than 0.5 L/s per Device (See Items 2, 3A and 3A1)

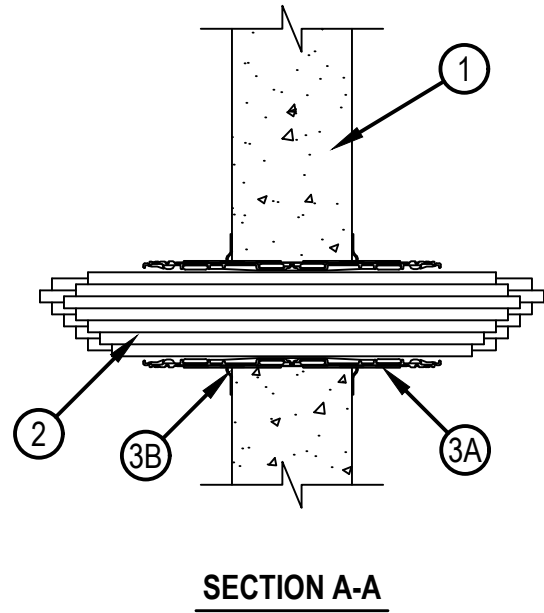
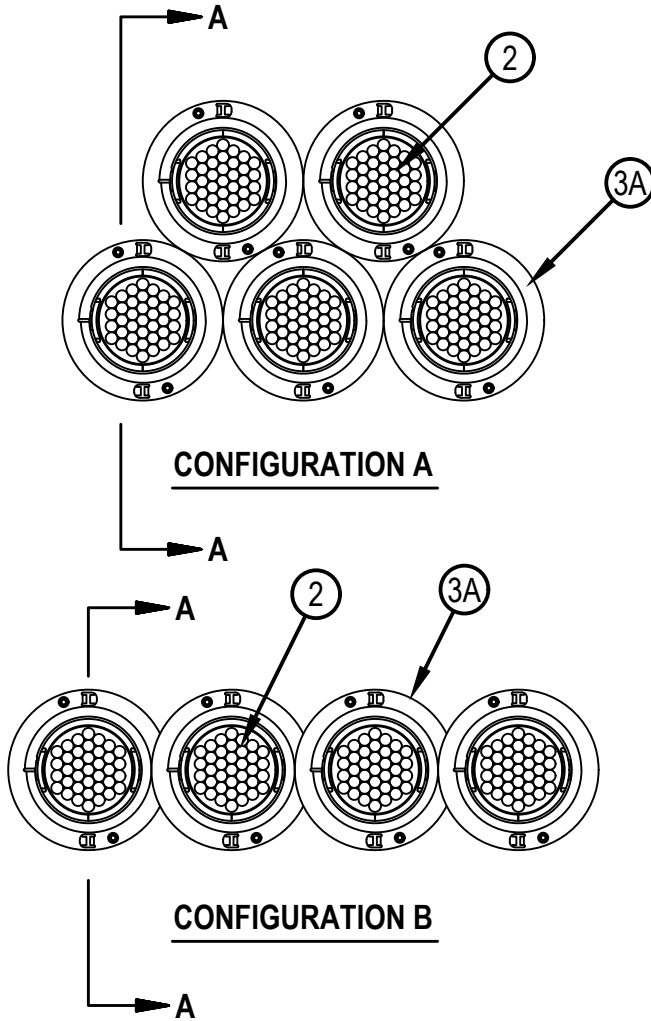

Reproduced by HILTI, Inc. Courtesy of
Underwriters Laboratories, Inc.
July 02, 2018

System No. W-J-3189

W-J-3189

1. Wall Assembly — Minimum 5 in. (127 mm) thick reinforced lightweight or normal weight (100-150 pcf or 1600-2400 kg/m³) concrete wall. Wall may also be constructed of any UL Classified Concrete Blocks*. Maximum five individual openings may be provided (see Item 3A). Diam of opening for each firestop device shall not exceed 4-1/2 in. (114 mm) and shall be sized to the OD of the firestop device.
See Concrete Blocks (CAZT) category in the Fire Resistance Directory for names of manufacturers.
2. Cables — The aggregate cross-sectional area of cables in firestop devices to be min 0 percent (blank) to max 100 percent visual fill. Cables to be tightly bundled within the device and rigidly supported on both sides of wall assembly. Any combination of the following types and sizes of cables may be used:
 - A. Max 100 pair No. 24 AWG (or smaller) copper conductor telecommunication cable with polyvinyl chloride (PVC) jacketing and insulation.
 - B. Max 7/C No. 12 AWG copper conductor control cable with PVC or XLPE jacket and insulation.
 - C. Max 4/0 AWG Type RHH ground cable.
 - D. Max 4 pr No. 22 AWG Cat 5 or Cat 6 computer cables.
 - E. Max RG 6/U coaxial cable with fluorinated ethylene insulation and jacketing.
 - F. Fiber optic cable with polyvinyl chloride (PVC) or polyethylene (PE) jacket and insulation having a max diam of 1/2 in. (13 mm).
 - G. Max 20/C No. 22 AWG shielded printer cable with PVC jacket.
 - H. Through-Penetrating Product* - Two copper conductors No. 18 AWG (or smaller) Power or Non Power Limited Fire Alarm Cable with or without a jacket under a metal armor.
AFC CABLE SYSTEMS INC
 - I. Max. 1/4 in. (6 mm) diameter S-Video Cable consisting of 2 max 24 AWG 75 ohm coax or twisted pair cable with PE insulation and PVC jacket .
 - J. Max 3/C No 12 AWG MC Cable.
 - K. Through Penetrating Product* — Any cables, Armored Cable+ or Metal Clad Cable+ currently Classified under the Through Penetrating Product category. See Through Penetrating Product (XHLY) category in the Fire Resistance Directory for names of manufacturers.

For opening with cables, the T, FT and FTH Ratings are 1/2 hr. For blank opening (no cables), the T, FT and FTH Ratings are 1-1/2 hr.

L Ratings vary depending on whether the gasketing material (see Item 3) or the sealant (Item 4) is used. See Table below for L Ratings.

Max Cable Fill	Cable Type	Type L Rating, CFM (L/s) Per Device			
		Ambient		400°F (204°C)	
		Sealant	Gasket	Sealant	Gasket
0%	—	Less than 1 (Less than 0.5)	Less than 1 (Less than 0.5)	Less than 1 (Less than 0.5)	Less than 1 (Less than 0.5)
100%	Item 2D only	Less than 1 (Less than 0.5)	Less than 1 (Less than 0.5)	Less than 1 (Less than 0.5)	Less than 1 (Less than 0.5)
100%	Any cables (Item 2) in any combination	1.2 (0.6)	1.2 (0.6)	1.3 (0.6)	1.6 (0.8)



Hilti Firestop Systems

Reproduced by HILTI, Inc. Courtesy of
Underwriters Laboratories, Inc.
July 02, 2018

3. Firestop System — The firestop system shall consist of the following:

A. Firestop Device* — Maximum five firestop devices grouped in two row configuration as depicted. The individual openings in the wall for each device are spaced min 2-7/16 in. (62 mm) apart such that the device flanges of adjacent devices are no closer than point contact. Firestop device consists of a corrugated steel tube with an inner plastic housing, intumescent material rings, twisted inner fabric smoke seal, flanges and gasketing material (not shown). Firestop device to be installed in accordance with the accompanying installation instructions. As an option, the inner fabric seal within each device may remain open except that, for all blank devices (no cables), the inner fabric seal shall be twisted to completely close the device. In addition, to attain the L Rating, the inner fabric seal must also be twisted to completely close the opening within each device. Device slid into wall such that ends project an equal distance from the approximate centerline of the wall assembly. Device provided with flanges that are spun clockwise onto device threads, over gasketing material butting tightly to both sides of wall. The annular space between each device and the periphery of the opening shall be nom 0 in. (point contact). Device flanges are to be secured to wall with min two 1-1/4 in. (32 mm) long masonry screws or anchors. As an alternate to gasket material, sealant (Item 3B) may be used.

HILTI CONSTRUCTION CHEMICALS, DIV OF HILTI INC — CP 653 and CP 653 BA 2" Speed Sleeve, CP 653 and CP 653 BA 4" Speed Sleeve, CFS-SL GA L Speed Sleeves, CP 653 4" BA ILS and CFS-SL GA L ILS Speed Sleeve.

The CFS-SL GA L and CFS-SL GA L ILS Speed Sleeves shall only be used in wall thickness of 8 in. (203 mm) or greater.

A1. Firestop Device* — Same as Item A above except maximum four firestop devices grouped in one row as depicted. The individual openings in the wall for each device are spaced min 1-7/16 in. (36.5 mm) apart. Device flanges may overlap one another. As an option, the inner fabric seal may remain open except that, to attain the L Rating, the inner fabric seal shall be twisted to completely close off the opening within each device.

HILTI CONSTRUCTION CHEMICALS, DIV OF HILTI INC — CP 653 and CP 653 BA 2" Speed Sleeve, CP 653 and CP 653 BA 4" Speed Sleeve, CFS-SL GA L Speed Sleeves, CP 653 4" BA ILS and CFS-SL GA L ILS Speed Sleeve.

The CFS-SL GA L and CFS-SL GA L ILS Speed Speed Sleeves shall only be used in wall thickness of 8 in. (203 mm) or greater.

B. Fill, Void or Cavity Material* — As an alternate to gasket material (see Item 3A), min 1/4 in. (6 mm) bead of fill material applied around periphery of each device to wall interface on both sides of wall prior to installing device flanges.

HILTI CONSTRUCTION CHEMICALS, DIV OF HILTI INC — CP 606 or FS-ONE MAX Intumescent Sealant.

* Indicates such products shall bear the UL or cUL Certification Mark for jurisdictions employing the UL or cUL Certification (such as Canada), respectively.

