



Classified by  
Underwriters Laboratories, Inc.  
to UL 1479 and CAN/ULC-S115

# System No. W-L-1164

WL 1164

ANSI/UL 1479 (ASTM E814)	CAN/ULC S115
F Ratings — 1 and 2 Hr (See Items 1 and 4)	F Ratings — 1 and 2 Hr (See Items 1 and 4)
T Rating — 0 Hr	FT Rating — 0 Hr
	FH Ratings — 1 and 2 Hr (See Items 1 and 4)
	FTH Rating — 0 Hr

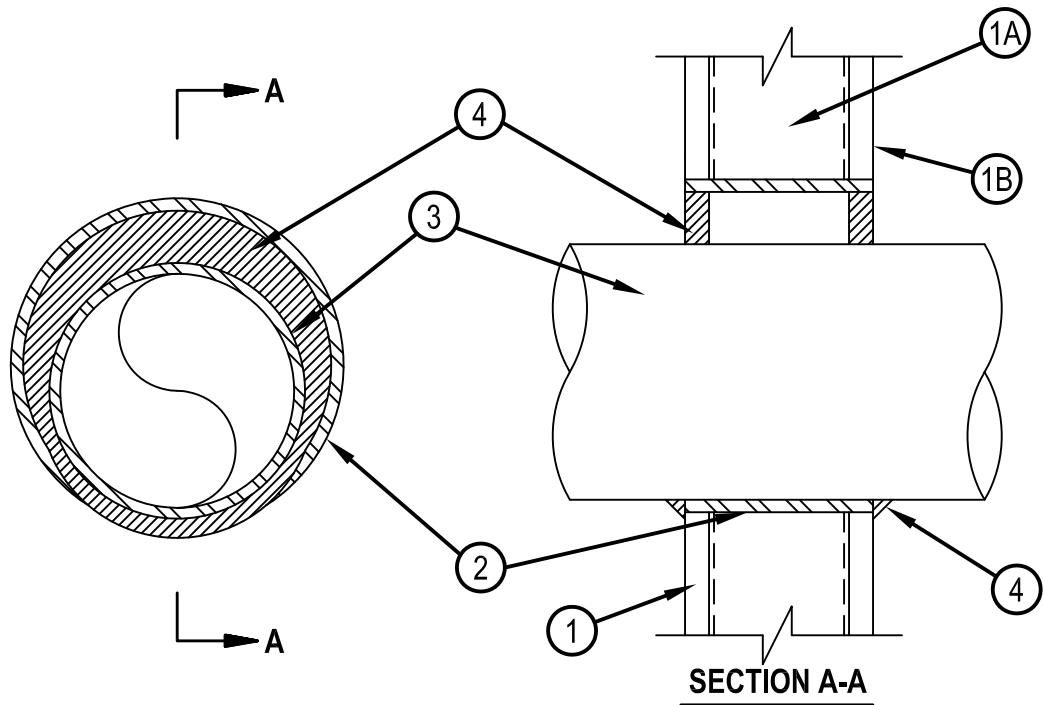

1. Wall Assembly — The 1 or 2 hr fire-rated gypsum wallboard/stud wall assembly shall be constructed of the materials and in the manner described in the individual U300, U400, V400 or W400 Series Wall or Partition Design in the UL Fire Resistance Directory and shall include the following construction features:

- A. Studs — Wall framing may consist of either wood studs or steel channel studs. Wood studs to consist of nom 2 by 4 in. (51 by 102 mm) lumber spaced 16 in. (406 mm) OC. Steel studs to be min 2-1/2 in. (64 mm) wide and spaced max 24 in. (610 mm) OC. When steel studs are used and the diam of opening exceeds the width of stud cavity, the opening shall be framed on all sides using lengths of steel stud installed between the vertical studs and screw-attached to the steel studs at each end. The framed opening in the wall shall be 4 to 6 in. (102 to 152 mm) wider and 4 to 6 in. (102 to 152 mm) higher than the diam of the penetrating item such that, when the penetrating item is installed in the opening, a 2 to 3 in. (51 to 76 mm) clearance is present between the penetrating item and the framing on all four sides.
- B. Gypsum Board\* — The gypsum wallboard type, thickness, number of layers, fastener type and sheet orientation shall be as specified in the individual Wall and Partition Design. Max diam of opening in steel stud walls is 32 in. (813 mm). Max diam of openings in wood stud walls is 14-1/2 in. (368 mm).

The hourly F, FH Ratings of the firestop system are equal to the hourly fire rating of the wall assembly in which it is installed.

2. Steel Sleeve — Nom 32 in. (813 mm) diam (or smaller) Schedule 40 (or heavier) steel pipe sleeve friction fit in nom 32 in. (813 mm) diam circular opening cut through gypsum board layers. Length of steel sleeve to be equal to thickness of wall.

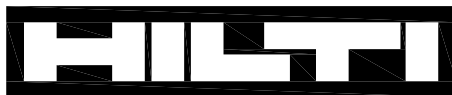

**Hilti Firestop Systems**

Reproduced by HILTI, Inc. Courtesy of  
Underwriters Laboratories, Inc.  
January 22, 2015

3. Through-Penetrant — One metallic pipe, conduit or tubing installed either concentrically or eccentrically within the firestop system. The annular space between pipe, conduit or tubing and the steel sleeve shall be min of 0 in. (point contact) to max 1-7/8 in. (48 mm) Pipe, conduit or tubing to be rigidly supported on both sides of wall assembly. The following types and sizes of metallic pipes, conduits or tubing may be used:
- A. Steel Pipe — Nom 30 in. (762 mm) diam (or smaller) Schedule 10 (or heavier) steel pipe.
  - B. Iron Pipe — Nom 30 in. (762 mm) diam (or smaller) service weight (or heavier) cast iron soil pipe or Class 50 (or heavier) ductile iron pressure pipe.
  - C. Conduit — Nom 4 in. (102 mm) diam (or smaller) steel electrical metallic tubing.
  - D. Copper Tubing — Nom 6 in. (152 mm) diam (or smaller) Type L (or heavier) copper tubing.
  - E. Copper Pipe — Nom 6 in. (152 mm) diam (or smaller) Regular (or heavier) copper pipe.
4. Fill, Void or Cavity Material\*-Sealant — Min 5/8 in. (16 mm) and 1-1/4 in. (32 mm) thickness of fill material applied within annulus, flush with both surfaces of wall assembly for 1 or 2 hr rated walls, respectively. Min 1/2 in. (13 mm) diam bead of caulk applied to the penetrant/gypsumboard interface at the point contact location on both sides of wall.  
HILTI CONSTRUCTION CHEMICALS, DIV OF HILTI INC — FS-ONE Sealant or FS-ONE MAX Intumescent Sealant
- \* Indicates such products shall bear the UL or cUL Certification Mark for jurisdictions employing the UL or cUL Certification (such as Canada), respectively.

