

**FIRE-RATED JOINT THROUGH CONCRETE WALL OR BLOCK WALL ASSEMBLY**

**ASSEMBLY RATING = 3-HR.**

**CLASS II AND CLASS III MOVEMENT CAPABILITIES - 25% COMPRESSION OR EXTENSION**

**CROSS-SECTIONAL VIEW**

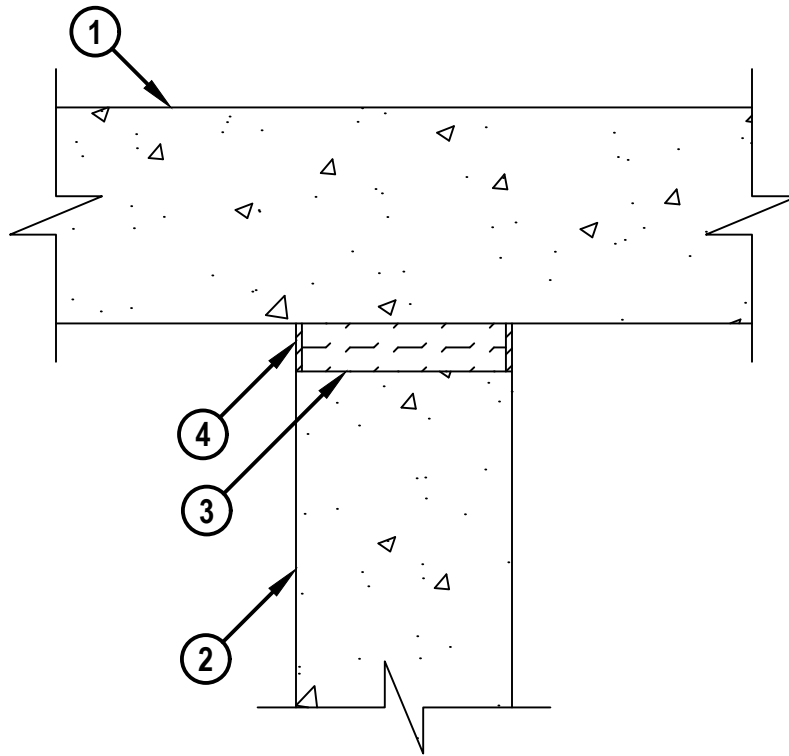

HWD0929a.062521

1. LIGHTWEIGHT OR NORMAL WEIGHT CONCRETE FLOOR (MINIMUM 4-1/2" THICK) (3-HR. FIRE-RATING).
2. CONCRETE WALL ASSEMBLY (3-HR. FIRE-RATING) :
  - A. LIGHTWEIGHT OR NORMAL WEIGHT CONCRETE WALL (MINIMUM 4-1/2" THICK).
  - B. ANY UL/cUL CLASSIFIED CONCRETE BLOCK WALL.
3. MINIMUM 4" THICKNESS MINERAL WOOL SAFING (MIN. 4 PCF DENSITY) COMPRESSED MINIMUM 50% AND RECESSED TO ACCOMMODATE FIRESTOP JOINT SPRAY.
4. MINIMUM 1/8" (WET) THICKNESS HILTI CFS-SP WB FIRESTOP JOINT SPRAY APPLIED WITHIN THE JOINT, FLUSH WITH BOTH SURFACES OF WALL.

**NOTE : MAXIMUM WIDTH OF JOINT = 1".**



HILTI, Inc.  
Plano, Texas USA (800) 879-8000

Sheet	1 of 1
Scale	1/4" = 1"
Date	June 25, 2021

Drawing No.  
**HWD  
0929a**