



Classified by  
Underwriters Laboratories, Inc.  
to UL 1479 and CAN/ULC-S115

# System No. W-L-7151

WL 7151

ANSI/UL1479 (ASTM E814)	CAN/ULC S115
F Ratings - 1 and 2 Hr (See Item 1)	F Ratings - 1 and 2 Hr (See Item 1)
T Rating - 0, 1, and 2 Hr (See Item 4C)	FT Rating - 0, 1, and 2 Hr (See Item 4C)
	FH Ratings - 1 and 2 Hr (See Item 1)
	FTH Ratings - 0, 1, and 2 Hr (See Item 4C)

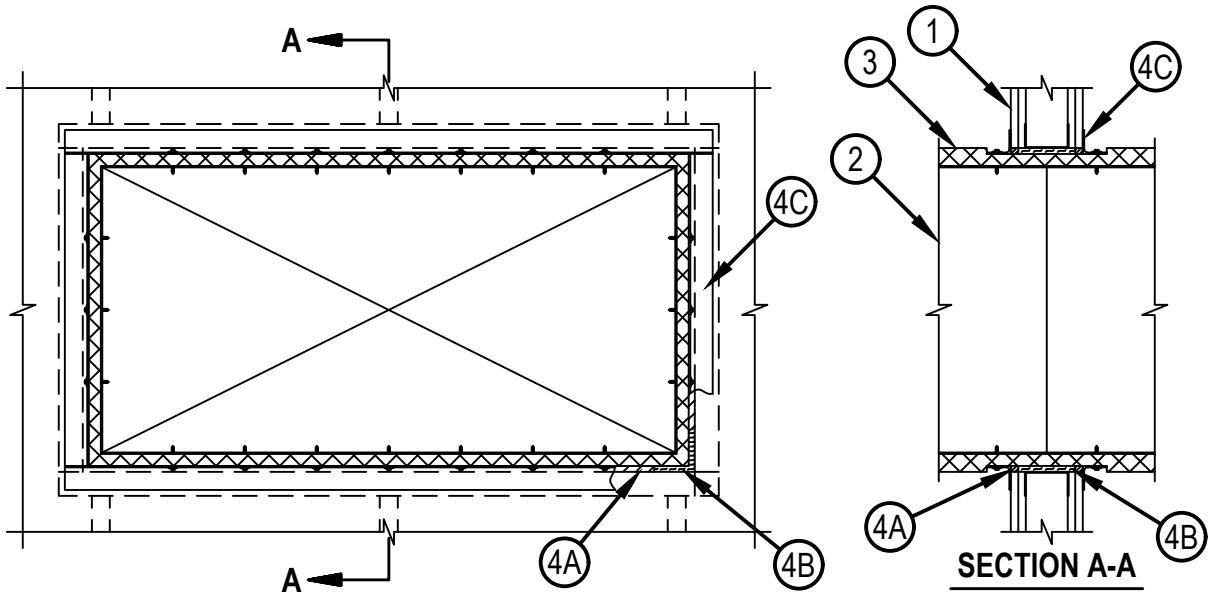

- 1. Wall Assembly** — The fire-rated gypsum board/stud wall assembly shall be constructed of the materials and in the manner specified in the individual U300, U400, V400 or W400 Series Wall and Partition Designs in the Fire Resistance Directory and shall include the following construction features:

  - A. Studs** — Wall framing may consist of either wood studs or steel channel studs. Wood studs to consist of nom 2 by 4 in. (51 by 102 mm) lumber spaced 16 in. (406 mm) OC. Steel studs to be min 3-1/2 in. (89 mm) wide and spaced max 24 in. (610 mm). Additional framing members shall be used to completely frame around opening.
  - B. Gypsum Board\*** — Nom 5/8 in. (16 mm) thick with square or tapered edges. The gypsum wallboard type, number of layers and sheet orientation shall be as specified in the individual Wall and Partition Design Number. Max area of opening is 210 sq in. (1355 cm<sup>2</sup>) with a max width of 14-1/2 in. (368 mm) for wood studs. Max area of opening is 2457 in<sup>2</sup> (1.58 m<sup>2</sup>) with the max length or width dimension of 63 in. (1600 mm) for steel studs. The hourly F and FH Ratings of the firestop system are equal to the hourly fire rating of the wall assembly in which it is installed.
- 2. Steel Duct** — Nom 36 in. by 60 in. (914 mm by 1524 mm or smaller) galv steel duct to be installed within the firestop system. The duct shall be constructed and reinforced in accordance with SMACNA construction standards. Duct to be rigidly supported on both sides of the wall assembly.
- 3. Batts and Blankets\*** — Max 2 in. (51 mm) thick min 3/4 pcf (12 kg/m<sup>3</sup>) glass fiber batt or blanket jacketed on the outside with a foil-scrim-kraft facing. Longitudinal and transverse joints sealed with aluminum foil tape. During the installation of the fill material, the batt or blanket shall be compressed minimum 50% such that the annular space within the firestop system shall be min 1/4 in. (6 mm) to a max 3-1/2 in. (89mm); refer to the table below.  
See Batts and Blankets - (BKNV) category in the Building Materials Directory for names of manufacturers. Any batt or blanket meeting the above specifications and bearing the UL Classification Marking with a Flame Spread Index of 25 or less and a Smoke Developed Index 50 or less may be used.



**Hilti Firestop Systems**

Reproduced by HILTI, Inc. Courtesy of  
Underwriters Laboratories, Inc.  
August 22, 2018

# System No. W-L-7151

WL 7151

4. Firestop System — The firestop system shall consist of the following:

- A. Packing Material — Min 3-1/2 in. (89 mm) thickness of min 4.0 pcf (64 kg/m<sup>3</sup>) mineral wool batt insulation firmly packed into the opening as a permanent form. Packing material to be recessed from both sides of the wall to accommodate the required thickness of fill material.
- B. Fill, Void or Cavity Material\*—Sealant — Min 5/8 in. (16 mm) thickness of fill material applied within annulus flush with both surfaces of the wall.

HILTI CONSTRUCTION CHEMICALS, DIV OF HILTI INC — FS-ONE MAX Intumescent Sealant

- C. Steel Retaining Angle — No. 18 MSG (or heavier) galv steel angles. When duct dimension exceeds 48 in. (1219 mm), angles shall be No. 16 MSG (or heavier). Angles cut to fit contour of duct with a 2 in. (51 mm) overlap on the duct and a min 1 in. (25 mm) overlap on the gypsum board assembly on both surfaces of wall. 2 in. (51 mm) leg of angle secured to duct with min No. 8 by 3/4 in. (19 mm) long sheet metal screws, spaced a max of 6 in. (152 mm) OC. Angles are optional for ducts 30 in. (762 mm) by 24 in. (610 mm) and smaller. In addition, see table below for additional conditions and options regarding retaining angles.

Max Duct Dimension	Duct Thickness	Max Insulation Thickness (Item 3)	Annular Space	Packing Material (Item 4A) Required	Angle (Item 4C) Required	T-Rating Hr
**24 in. (610 mm)	24 ga or heavier	1-1/2 in. (38 mm)	1/4 in. min to 1 in. max (6 to 25 mm)	No	No	0
25 in. (635 mm) wide by 45 in. (1143 mm) high	24 ga or heavier	2 in. (51 mm)	1/4 in. min to 3-1/2 in. max (6 to 89 mm)	Yes	No	1 and 2 (Same as wall rating)

\*\* Indicates that when max 1-1/2 in. (38 mm) thick insulation is used, steel angles are optional for those sides of the duct that do not exceed the dimension specified.

\* Indicates such products shall bear the UL or cUL Certification Mark for jurisdictions employing the UL or cUL Certification (such as Canada), respectively.



Reproduced by HILTI, Inc. Courtesy of Underwriters Laboratories, Inc.  
August 22, 2018