



Classified by
Underwriters Laboratories, Inc.
to UL 2079 and CAN/ULC-S115

System No. HW-D-0209

HWD 0209

ANSI/UL2079	CAN/ULC S115
Assembly Ratings — 1, 2, 3 and 4 Hr (See Item 2)	F Ratings — 1, 2, 3 and 4 Hr (See Item 2)
Nominal Joint Width — 3/4, 7/8 or 1 In. (See Item 3)	FT Ratings — 1, 2, 3 and 4 Hr (See Item 2)
Class II Movement Capabilities — 19% Compression or Extension, 16% Extension and 33% Compression or 43% Compression (See Item 3)	FH Ratings — 1, 2, 3 and 4 Hr (See Item 2)
L Rating At Ambient — Less Than 1 CFM/lin ft (See Item 3)	FTH Ratings — 1, 2, 3 and 4 Hr (See Item 2)
L Rating At 400°F — Less Than 1 CFM/lin ft (See Item 3)	Nominal Joint Width — 3/4, 7/8 or 1 In. (See Item 3)
	Class II Movement Capabilities — 19% Compression or Extension, 16% Extension and 33% Compression or 43% Compression (See Item 3)
	L Rating At Ambient — Less Than 1.55 L/s/m (See Item 3)
	L Rating At 204°C — Less Than 1.55 L/s/m (See Item 3)

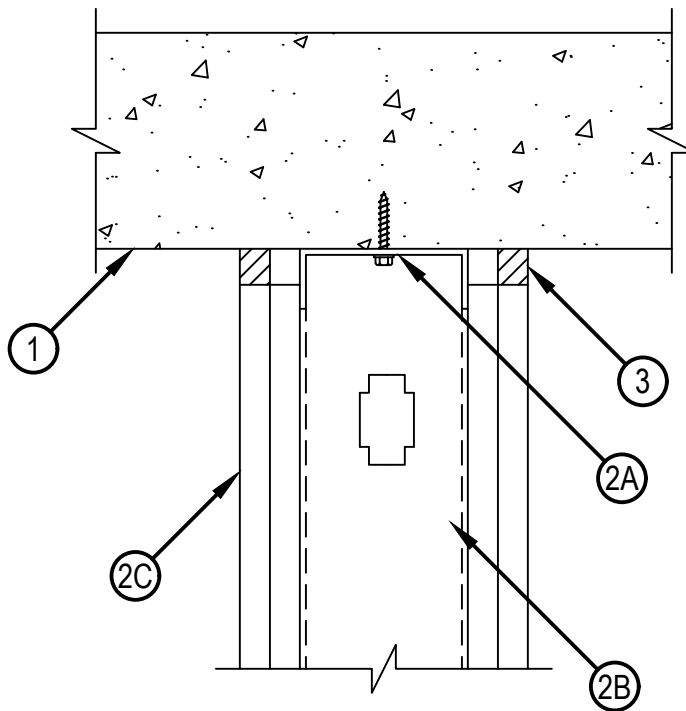

1. Floor Assembly — Min 4-1/2 in. (114 mm) thick reinforced lightweight or normal weight (100-150 pcf or 1600-2400 kg/m³) structural concrete. Floor may also be constructed of any 6 in. (152 mm) thick UL Classified hollow-core Precast Concrete Units*. See Precast Concrete Units category in the Fire Resistance Directory for names of manufactures.
2. Wall Assembly — The 1, 2, 3 or 4 hr fire rated gypsum board/steel stud wall assembly shall be constructed of the materials and in the manner specified in the individual U400, V400 or W400 Series Wall and Partition Design in the UL Fire Resistance Directory and shall include the following construction features:



Hilti Firestop Systems

Reproduced by HILTI, Inc. Courtesy of
Underwriters Laboratories, Inc.
June 26, 2023

A. Steel Floor and Ceiling Runners — Floor and ceiling runners of wall assembly shall consist of min No. 25 gauge galv steel channels sized to accommodate steel studs (Item 2B). Flange height of ceiling runner shall be min 1/4 in. (6 mm) greater than max extended joint width. Ceiling runner secured with masonry anchors or steel fasteners spaced 24 in. (610 mm) OC.

A1. Light Gauge Framing* — Slotted Ceiling Runner - As an alternate to the ceiling runner in Item 2A, slotted ceiling runner to consist of galv steel channel with slotted flanges sized to accommodate steel studs (Item 2B). Slotted ceiling runner secured to valleys lower surface of floor with steel fasteners spaced max 24 in. (610 mm) OC.

BRADY CONSTRUCTION INNOVATIONS INC, DBA SLIPTRACK SYSTEMS — SLP-TRK

CEMCO, LLC — CST

MARINO/WARE, DIV OF WARE INDUSTRIES INC — Type SLT

A2. Light Gauge Framing* — Vertical Deflection Ceiling Runner - As an alternate to the ceiling runners in Items 2A and 2A1, vertical deflection ceiling runner to consist of galv steel channel with slotted vertical deflection clips mechanically fastened within runner. Slotted clips provided with step bushings for permanent fastening of steel studs. Flanges sized to accommodate steel studs (Item 2B). Vertical deflection ceiling runner secured to lower surface of floor with steel fasteners spaced max 24 in. (610 mm) OC.

THE STEEL NETWORK INC — VertiTrack VTD250, VTD362, VTD400, VTD600 and VTD800

B. Studs — Steel studs to be min 3-1/2 in. (89 mm) wide. Studs cut 1/2 to 3/4 in. (13 to 19 mm) less in length than assembly height with bottom nesting in and resting on floor runner and with top nesting in ceiling runner without attachment. When slotted ceiling runner (Item 2A1) is used, steel studs secured to slotted ceiling runner with No. 8 by 1/2 in. (13 mm) long wafer head steel screws at mid-height of slot on each side of wall. Stud spacing not to exceed 24 in. (610 mm) OC. When vertical deflection ceiling runner (Item 2A2) is used, steel studs secured to slotted vertical deflection clips, through the bushings, with steel screws at mid-height of each slot. Stud spacing not to exceed 24 in. (610 mm) OC.

C. Gypsum Board* — One, two, three or four layers of 5/8 in. (16 mm) thick gypsum board for 1, 2, 3 and 4 hr rated assemblies, respectively, as required in the individual Wall and Partition Design. Wall to be constructed as specified in the individual U400 or V400 Series Design in the UL Fire Resistance Directory, except that a max 1 in. (25 mm) gap shall be maintained between the top of gypsum board and bottom of concrete floor for 1 and 2 hr rated assemblies or a max 3/4 in. (19 mm) or 7/8 in. (22 mm) for 3 and 4 hr rated assemblies, dependent on the movement capabilities described in Item 3.. The screws attaching the gypsum board to the studs at the top of the first layer shall be located 4 in. (102 mm) below the floor. The screws attaching the second layer to the steel studs shall be installed into the studs 3-1/2 in. (89 mm) below the floor. The screws attaching the gypsum board to the studs at the top of the third and fourth layers shall be located 5 in. (102 mm) and 6 in. (152 mm) below the floor, respectively.

The hourly fire rating of the joint system is equal to the hourly ratings of the walls.

3. Fill, Void or Cavity Material* - Sealant — Max separation between bottom of floor and top of wall is 1 in. (25 mm) for 1 and 2 hr rated assemblies. The joint system is designed to accommodate a max 19 percent compression or extension from its installed width. Max separation between bottom of floor and top of wall is 3/4 in. (19 mm) or 7/8 in. (22 mm) for 3 and 4 hr rated assemblies. The joint system is designed to accommodate a max 16 percent extension or 33 percent compression from its installed width for 3/4 in. (19 mm) joints or 43 percent compression only for 7/8 in. joints. Min 5/8 in. (16 mm) thickness of fill material installed on each side of the wall between the top of the gypsum board and the bottom of the concrete floor, flush with each surface of the wall for 1 and 2 hr rated assemblies. Min 1 in. (25 mm) thickness of fill material installed on each side of the wall between the top of the gypsum board and the bottom of the concrete floor, flush with each surface of the wall for 3 and 4 hr rated assemblies.

HILTI CONSTRUCTION CHEMICALS, DIV OF HILTI INC — CP601S Elastomeric Firestop Sealant or CP606 Flexible Firestop Sealant or CFS-S SIL GG Sealant. L Ratings apply only when CP606 or CFS-S SIL GG Sealant is used.

4. Forming Material — (Optional, Not Shown) - Mineral wool insulation, fiberglass batt insulation or polyurethane/polyethylene foam backer rod. Forming material to be recessed from both surfaces of the 2, 3 and 4 hr fire rated wall to accommodate the required thickness of fill material.

* Indicates such products shall bear the UL or cUL Certification Mark for jurisdictions employing the UL or cUL Certification (such as Canada), respectively.

