

TOP OF WALL JOINT : GYPSUM WALL ASSEMBLY

ASSEMBLY RATING = 1-HR. OR 2-HR.

L-RATING AT AMBIENT = LESS THAN 1 CFM / LIN FT

L-RATING AT 400°F = LESS THAN 1 CFM / LIN FT

CLASS II AND III MOVEMENT CAPABILITIES - 50% COMPRESSION OR EXTENSION OR 66% COMPRESSION ONLY (SEE NOTES NO. 2 AND 3 BELOW)

HWDD0757g.032323

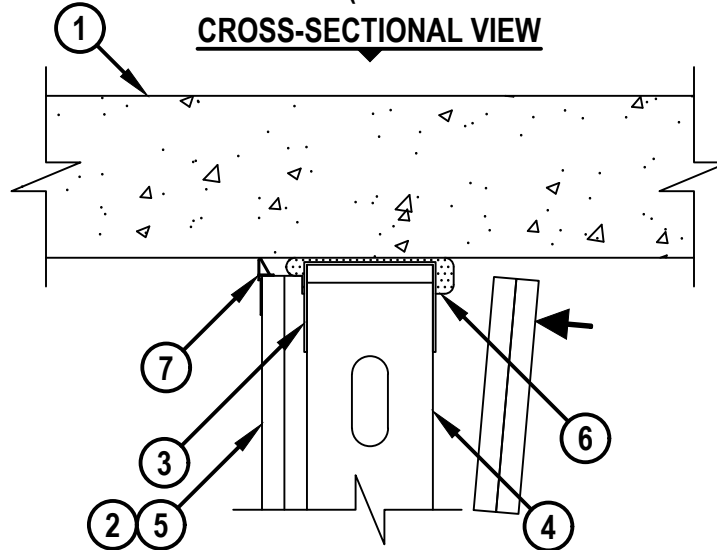

1. CONCRETE FLOOR ASSEMBLY (2-HR. FIRE-RATING) :
 - A. LIGHTWEIGHT OR NORMAL WEIGHT CONCRETE FLOOR (MINIMUM 4-1/2" THICK).
 - B. ANY UL/cUL CLASSIFIED PRECAST (HOLLOW-CORE) CONCRETE FLOOR (MINIMUM 6" THICK).
2. GYPSUM WALL ASSEMBLY (UL/cUL CLASSIFIED U400 OR V400 SERIES) (1-HR. OR 2-HR. FIRE-RATING) (2-HR. SHOWN).
3. CEILING RUNNER (MIN. 25 GA., FLANGE HEIGHT OF CEILING RUNNER SHALL BE MINIMUM 1/4" GREATER THAN MAXIMUM EXTENDED JOINT WIDTH) FASTENED TO UNDERSIDE OF CONCRETE FLOOR WITH MASONRY ANCHORS OR STEEL FASTENERS (SPACED MAX. 24" OC) (SEE NOTE NO. 1 BELOW).
4. STEEL STUDS (MINIMUM 3-1/2" WIDE) CUT 3/4" TO 1" LESS IN LENGTH THAN ASSEMBLY HEIGHT WITH BOTTOM NESTING IN CEILING RUNNER WITHOUT ATTACHMENT.
5. 5/8" OR 1-1/4" THICKNESS GYPSUM WALLBOARD AS SPECIFIED IN THE INDIVIDUAL UL DESIGN. TOP ROW OF SCREWS SHALL BE INSTALLED INTO STUD 1" TO 1-1/2" BELOW THE BOTTOM EDGE OF THE CEILING RUNNER.
6. HILTI CFS-TTS 212, CFS-TTS 358, CFS-TTS 600, CFS-TTS OS, OR CFS-TTS R OS FIRESTOP TOP TRACK SEAL INSTALLED OVER CEILING RUNNER PRIOR TO ATTACHMENT TO UNDERSIDE OF CONCRETE FLOOR IN ACCORDANCE WITH THE ACCOMPANYING INSTALLATION INSTRUCTIONS.
7. [OPTIONAL] PVC WALL MOUNTED DEFLECTION BEAD (BY TRIM-TEX INC.) INSTALLED PER MANUFACTURER'S INSTRUCTIONS. DEFLECTION BEAD INSTALLED ON ONE OR BOTH SIDES OF WALL.

NOTES : 1. AS AN ALTERNATE TO CEILING RUNNER IN ITEM 3, SLOTTED CEILING RUNNERS MAY BE USED FOR MIN 3-5/8" STUDS ONLY. CONSULT THE UL FIRE RESISTANCE DIRECTORY FOR APPROVED MANUFACTURERS.
 2. TO ACCOMMODATE MAX. 50% COMPRESSION OR EXTENSION MAX. WIDTH OF JOINT = 1/2".
 3. TO ACCOMMODATE MAX. 66% COMPRESSION ONLY MAX. WIDTH OF JOINT = 3/4".



HILTI, Inc.
 Plano, Texas USA (800) 879-8000

Sheet	1 of 1
Scale	3/16" = 1"
Date	Mar. 23, 2023

Drawing No.
**HWD
 0757g**