



Classified by
Underwriters Laboratories, Inc.
to UL 2079 and CAN/ULC-S115

System No. HW-D-0884

HWD 0884

ANSI/UL2079	CAN/ULC S115
Assembly Ratings — 1 and 2 Hr (See Item 2)	F Ratings — 1 and 2 Hr (See Item 2)
Nominal Joint Widths — 7/8, 1 or 1-5/8 In. (See Item 3)	FT Ratings — 1 and 2 Hr (See Item 2)
Class II Movement Capabilities — 62% Compression or Extension, 86 Compression or Extension or 92% Compression only (See Item 3-Table 1)	FH Ratings — 1 and 2 Hr (See Item 2)
L Rating At Ambient — Less Than 1 CFM/Lin ft	FTH Ratings — 1 and 2 Hr (See Item 2)
L Rating At 400°F — Less Than 1 CFM/Lin ft	Nominal Joint Widths — 22, 25.4 or 41 mm (See Item 3)
	Class II Movement Capabilities — 62% Compression or Extension, 86 Compression or Extension or 92% Compression only (See Item 3-Table 1)
	L Rating At Ambient — Less Than 1.55 L/s/m
	L Rating At 204°C — Less Than 1.55 L/s/m

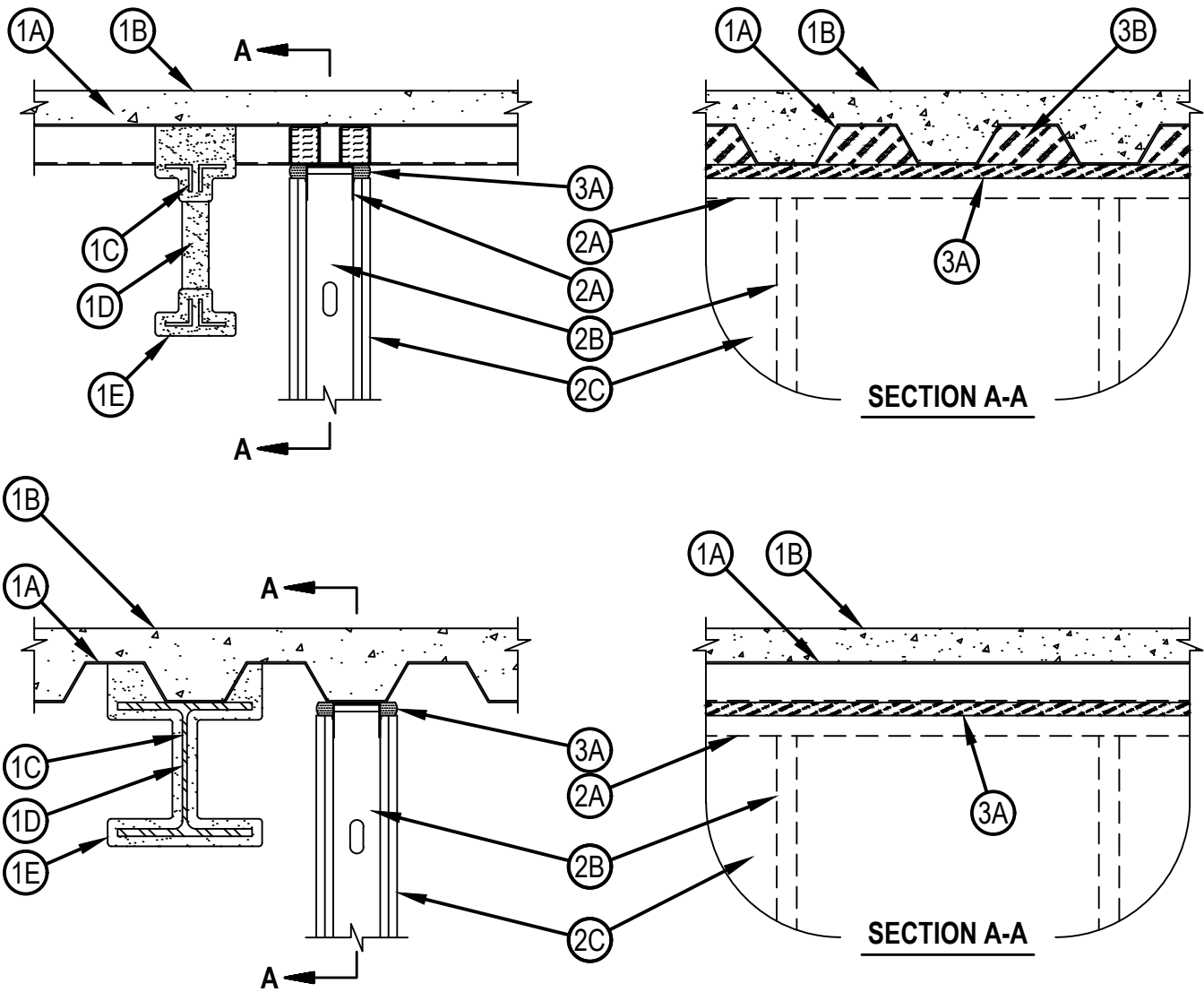

Hilti Firestop Systems

Reproduced by HILTI, Inc. Courtesy of
Underwriters Laboratories, Inc.
October 2, 2024

1. Floor Assembly — The fire-rated fluted steel deck/concrete floor assembly shall be constructed of the materials and in the manner described in the individual D900 Series Floor-Ceiling Design in the UL Fire Resistance Directory. The hourly fire rating of the floor assembly shall be equal to or greater than the hourly fire rating of the wall assembly. The floor assembly shall include the following construction features:
 - A. Steel Floor and Floor Units* — Max 3 in. (76 mm) deep galv steel fluted floor units.
 - B. Concrete — Min 2-1/2 in. (64 mm) thick reinforced concrete, as measured from the top plane of the floor units.
 - C. Structural Steel Support — Steel beam or open-web steel joist, as specified in the individual D900 Series Floor-Ceiling Design, used to support steel floor units. Structural steel support oriented parallel to and max 4 in. (25 to 102 mm) from wall assembly.
 - D. Steel Lath — When structural steel support (Item 1C) consists of open-web steel joists, 3/8 in. (10 mm) diamond mesh expanded steel lath having a nom weight of 1.7 to 3.4 lb per sq yd (0.9 to 1.8 kg/m²) shall be installed to completely cover one side of each joist which is located within 4 in. (102 mm) of wall assembly. The lath shall be secured with steel tie wire and shall be fully covered with spray applied fire resistive material.
 - E. Spray-Applied Fire Resistive Material* — After installation of the ceiling runner (Item 2A), and Top Track Seal (Item 3A), structural steel supports to be sprayed with the thickness of material specified in the individual D900 Series Design. The flutes of the steel floor units above the structural steel supports shall be filled with spray-applied fire resistive material.
 - ISOLATEK INTERNATIONAL — Type 300, Type 400
 - GCP APPLIED TECHNOLOGIES INC — Type MK-6/HY, MK-6/HY ES, MK-6s, RG, MK-10HB
2. Wall Assembly — The 1 or 2 hr fire-rated gypsum board/steel stud wall assembly shall be constructed of the materials and in the manner described in the individual U400, V400 or W400 Series Wall and Partition Design in the UL Fire Resistance Directory and shall include the following construction features:
 - A. Steel Floor and Ceiling Runners — Floor and ceiling runners of wall assembly shall consist of galv steel channels sized to accommodate steel studs (Item 2B). Legs of ceiling runner to be min 2-1/2 in. (64 mm) long. Ceiling runner is secured to steel floor units (Item 1A) after installation of Top Track Seal (Item 3A) with steel fasteners spaced max 24 in. (610 mm) OC. Ceiling runner to be installed parallel with structural steel support and located such that a max clearance of 4 in. (102 mm) is present between the finished wall and the spray-applied fire resistive material at the lowest elevation of the structural steel support. Ceiling runner may be installed parallel to and centered below, or perpendicular to, flutes in steel floor units.
 - A1. Light Gauge Framing* — Slotted Ceiling Runner — As an alternate to the ceiling runner in Item 2A, ceiling runner to consist of galv steel channel with min 2-1/2 in. (64 mm) slotted flanges sized to accommodate steel studs (Item 2B). Ceiling runner secured to valleys with steel fasteners spaced max 24 in. (610 mm) OC.
 - CEMCO, LLC — CST, CST325
 - MARINO/WARE, DIV OF WARE INDUSTRIES INC — Type SLT
 - A2. Light Gauge Framing* - Notched Ceiling Runner — As an alternate to the ceiling runners in Items 2A through 2A2, notched ceiling runners to consist of C-shaped galv steel channel with notched return flanges min 2-1/2 in. (64 mm) long, sized to accommodate steel studs (Item 2B). Notched ceiling runner secured to valleys with steel masonry anchors spaced max 24 in. (610 mm) OC.
 - OLMAR SUPPLY INC — Type SCR
 - A3. Light Gauge Framing* — Slotted Ceiling Runner — As an alternate to the ceiling runner in Item 2A, ceiling runner to consist of galv steel channel with slotted flanges sized to accommodate steel studs (Item 2B). Flange height of slotted ceiling runner shall be 3-1/4 in. (83 mm) with 2 in. (51 mm) deep slots. Ceiling runner secured to valleys with steel fasteners or welds spaced max 24 in. (610 mm) OC.
 - SCAFCO STEEL STUD MANUFACTURING CO — Slotted Track-Type SDLT
 - B. Studs — Steel studs to be min 3-1/2 in. (89 mm) wide. Studs cut 3/4 in. to 1 in. (19 to 25 mm) less in length than assembly height with bottom nesting in and secured to floor runner. When slotted ceiling runner (Item 2A1) is used, steel studs secured to slotted ceiling runner with No. 8 by 1/2 (13 mm) long wafer head steel screws at mid-height of slot on each side of wall.



System No. HW-D-0884

HWD 0884

C. Gypsum Board* — Gypsum board sheets installed to a min total 5/8 in. (16 mm) or 1-1/4 in. (32 mm) thickness on each side of wall for 1 and 2 hr fire rated assemblies, respectively. Wall to be constructed as specified in the individual U400, V400 or W400 Series Design in the UL Fire Resistance Directory. The screws attaching the gypsum board to the studs along the top of the wall shall be located 3-1/2 in. (89 mm) to 12 in. (305 mm) below the top of the ceiling runner. No gypsum board attachment screws shall be driven into the ceiling runner. Where the top of the wall assembly is inaccessible above the lowest elevation of the structural steel support, the gypsum board attachment screws may be omitted. The hourly fire rating of the joint system is equal to the hourly fire rating of the wall.

3. Joint System — Max separation between the steel floor units and top of gypsum board (at time of installation of joint system) is 7/8 in. (22 mm), 1 in (25mm), or 1-5/8 in (41mm). See Item 3-Table 1 for additional details Max separation between spray applied fire resistive material on structural support member and surface of wall is 4 in. (102 mm).

Table 1

Max Nom Joint Width, In. (mm)	Max Movement Capabilities, (% of nominal)		Max Movement, in. (mm)
7/8 (22)	Compression	86%	3/4 (19)
	Extension	86%	3/4 (19)
1 (25)	Compression	62%	5/8 (16)
	Extension	62%	5/8 (16)
1-5/8 (41)	Compression	92%	1-1/2 (38)
	Extension	0%	0

As an alternative to the movement percentages above, the joint system may move freely without restriction to the percentage of movement within the range of a min 1/8 in. (3 mm) to max 1-5/8 in. (41 mm) joint width.

A. Fill, Void or Cavity Material* — Top Track Seal — Factory supplied foam seal installed over the ceiling runner prior to attachment to underside of steel floor unit in accordance with the installation instructions. Butt joints in the Top Track Seal shall be compressed min 1/2 in. (13 mm).

HILTI CONSTRUCTION CHEMICALS, DIV OF HILTI INC — CFS-TTS MD OS or CFS-TTS MD 600 Firestop Top Track Seal

B. Forming Material* — Plugs — When ceiling runner is perpendicular to flutes, the fluted area of steel floor above the ceiling runner is to be filled with preformed plugs, formed to the shape of the flutes. The plug size to match deck height and to be friction fit above the ceiling runner, flush with both sides of the wall.

HILTI CONSTRUCTION CHEMICALS, DIV OF HILTI INC — CFS-TTS MD P 1.5, CFS-TTS MD P2, CFS-TTS MD P3 Firestop Top Track Plug

B1. Forming Material* — Plugs — (Optional, Not Shown) — As an alternate to Item 3B, preformed mineral wool plugs formed to the shape of the trapezoidal fluted floor units, friction fit to completely fill the flutes above the ceiling channel. The plugs shall project beyond each side of the ceiling runner, flush with wall surfaces.

HILTI CONSTRUCTION CHEMICALS, DIV OF HILTI INC — CP777 Speed Plugs

* Indicates such products shall bear the UL or cUL Certification Mark for jurisdictions employing the UL or cUL Certification (such as Canada), respectively.



Hilti Firestop Systems

Reproduced by HILTI, Inc. Courtesy of
Underwriters Laboratories, Inc.
October 2, 2024