



Classified by
Underwriters Laboratories, Inc.
to UL 2079 and CAN/ULC-S115

System No. HW-D-0874

HWD 0874

ANSI/UL2079	CAN/ULC S115
Assembly Rating — 2 Hr	F Rating — 2 Hr
Nominal Joint Width - 1 or 1-1/4 in. (See Item 3)	FT Rating — 2 Hr
Class II and III Movement Capabilities — 25% Compression or Extension or 60% Compression Only	FH Rating — 2 Hr
	FTH Rating — 2 Hr
	Nominal Joint Width - 25 or 32 mm (See Item 3)
	Class II and III Movement Capabilities — 25% Compression or Extension or 60% Compression Only

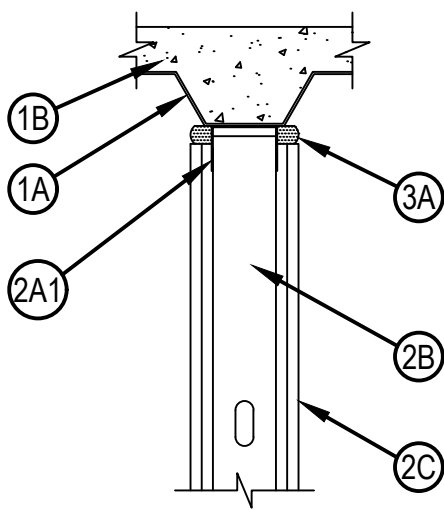
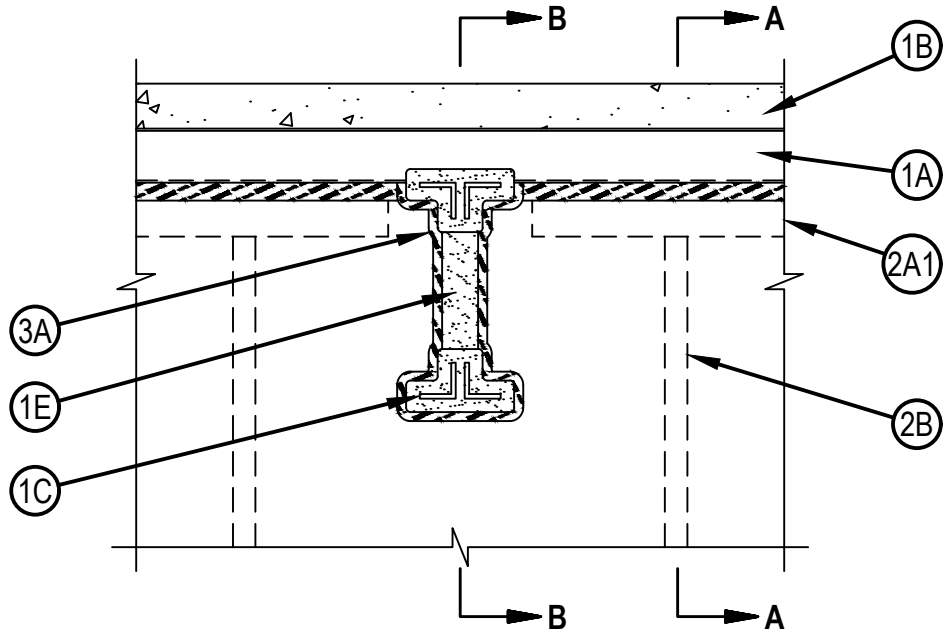

SECTION A-A

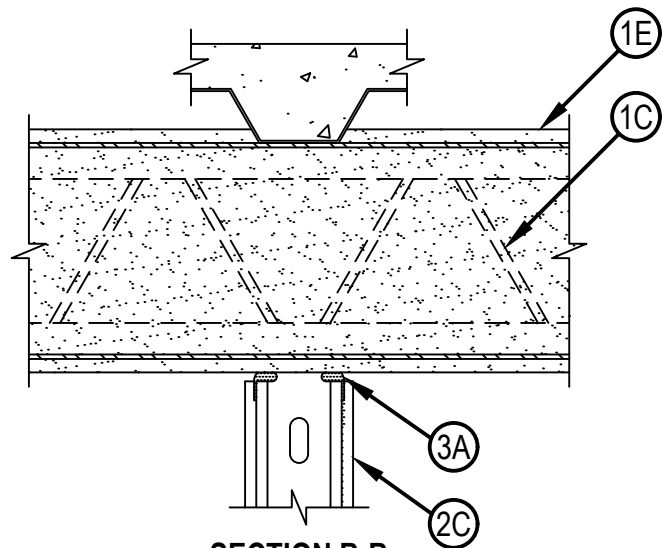

SECTION B-B



Hilti Firestop Systems

Reproduced by HILTI, Inc. Courtesy of
Underwriters Laboratories, Inc.
June 22, 2023

1. Floor Assembly — The fire-rated fluted steel floor unit/concrete floor assembly shall be constructed of the materials and in the manner described in the individual D900 Series Floor-Ceiling Design in the Fire Resistance Directory and shall include the following construction features:
 - A. Steel Floor and Form Units* — Max 3 in. (76 mm) deep galv steel fluted floor units.
 - B. Concrete — Min 2-1/2 in. (64 mm) thick reinforced concrete, as measured from the top plane of the floor units.
 - C. Structural Steel Support (Optional) — Steel beam or open-web steel joist, as specified in the individual D900 Series Floor-Ceiling Design, used to support steel floor units. Structural steel support oriented perpendicular to wall assembly.
 - D. Steel Lath — Where open-web steel joists pass through the fire rated wall, 3/8 in. diamond mesh expanded steel lath having a nom weight of 1.7 to 3.4 lb per sq yd (0.9 to 1.8 kg/m²) shall be secured to one side of each joist with steel tie wire and the lath shall be fully covered with no min thickness requirement.
 - E. Spray-Applied Fire Resistive Material* — — After the installation of the ceiling runner (Item 2A1), the structural steel supports to be sprayed in accordance with the specifications in the individual D900 Series Design. Material is to be excluded from the steel floor units, directly above the gypsum board and from the flanges of the ceiling runners.
 - ISOLATEK INTERNATIONAL — Type 300, Type 400
 - GCP APPLIED TECHNOLOGIES INC — Types MK-6/HY or MK-10HB
2. Wall Assembly* — The 2 h fire-rated gypsum board/stud wall assembly shall be constructed of the materials and in the manner specified in the individual U400, V400 or W400 Series Wall and Partition Design in the UL Fire Resistance Directory and shall include the following construction features:
 - A. Steel Floor Runner — Floor runner of wall assembly shall consist of min No. 25 gauge galv steel channel sized to accommodate steel studs (Item 2B). See Item 2A1 for ceiling runner.
 - A1. Light Gauge Framing*- Slotted Ceiling Runner — Slotted ceiling runner to consist of galv steel channel with slotted flanges sized to accommodate steel studs (Item 2B). Flange height of slotted ceiling runner shall be min 1/4 in. (6 mm) greater than max extended joint width. Slotted ceiling runner centered beneath and parallel with valley of steel floor units (Item 1A), or perpendicular to direction of fluted steel floor units, and secured with steel masonry anchors, steel fasteners or welds spaced max 24 in. (610 mm) OC. Ceiling runner to be secured within 1 in. (25 mm) of ends at the structural steel support.
 - BRADY CONSTRUCTION INNOVATIONS INC, DBA SLIPTRACK SYSTEMS — SLP-TRK, SLPTRK325
 - CEMCO, LLC — CST, CST325
 - CLARKDIETRICH BUILDING SYSTEMS — Types SLT, SLT-H
 - MARINO/WARE, DIV OF WARE INDUSTRIES INC — Type SLT
 - RAM SALES L L C — RAM Slotted Track
 - SCAFCO STEEL STUD MANUFACTURING CO
 - TELLING INDUSTRIES L L C — True-Action Deflection Track
 - THE STEEL NETWORK INC — VertTrack VT series, 250VT, 362VT, 400VT, 600VT and 800VT
 - B. Studs — Steel studs to be min 3-5/8 in. (92 mm) wide. Studs cut 1/2 to 1 in. (13 to 25 mm) less in length than assembly height with bottom nesting in and fastened to the floor runner and with top nesting in slotted ceiling runner. Steel studs secured to slotted ceiling runner with min No. 8 by 1/2 in. (13 mm) long wafer head steel screws at mid-height of slot on each side of wall. Stud spacing not to exceed 24 in. (610 mm) OC.
 - C. Gypsum Board* — Two layers of 5/8 in. (16 mm) thick gypsum board as specified in the individual Wall and Partition Design. A max 1 in. (25 mm) gap shall be maintained between the top of gypsum board and the bottom of the steel floor units. The screws attaching the gypsum board to studs at the top of the wall shall be located 3-1/2 in. (89 mm) to 5-1/2 in. (138 mm) below the bottom edge of the ceiling runner. The gypsum board shall be cut to contour around the structural steel support with a nom 1/2 in. (13 mm) gap between the spray applied fire resistive material on the support member and the cut edge of the gypsum board. The CFS-TTS MD (Item 3B) shall be friction fit between the first layer of gypsum board and the spray applied fire resistive material on the structural steel support, with the top portion of the CFS-TTS MD pressed against the face of the gypsum board and the rod fit into the gap around the beam and projecting slightly into the wall cavity. The top portion of the CFS-TTS MD will be sandwiched in by the second layer of gypsum board.



3. Joint System — When max separation between the bottom of steel floor unit and top of wall is 1 in. (25 mm), the joint system is designed to accommodate a max 25 percent compression or extension from its installed width. When max separation between the bottom of steel floor unit and top of wall is 1-1/4 in. (32 mm), the joint system is designed to accommodate a max 60% compression only from its installed width. Separation between spray-applied fire resistive material on structural support and cut edge of gypsum board is nom 1/2 in. (13 mm). The joint system consists of a fill material installed on the slotted ceiling runner and within the gap between first layer of gypsum board and the structural steel support as follows:

A. Fill, Void or Cavity Material* — Top Track Seal — Factory supplied foam seal installed over the slotted ceiling runner (Item 2A) prior to attachment to underside of steel floor unit in accordance with the installation instructions. In addition, Top Seal Track also friction fit between the first layer of gypsum board and the sprayed structural steel support with the top portion of the CFS-TTS pressed against the face of the gypsum board and the rod fit into the gap around the beam and projecting slightly into the wall cavity. The CFS-TTS will then be sandwiched in by the second layer of gypsum board.

HILTI CONSTRUCTION CHEMICALS, DIV OF HILTI INC — CFS-TTS MD OS or CFS-TTS MD 600 Firestop Top Track Seal

B. Forming Material* — Flute Plugs (Not Shown) — When wall is oriented perpendicular to the fluted deck, the fluted area of the steel floor above the wall is filled with preformed flute plugs, formed to the shape of the flutes. The plug size to match deck height and to be friction fit above the ceiling runner, flush with the outer surface of the Top Track Seal (Item 3A) at both sides of wall. Where a partial flute exists, the Flute Plug can be cut to fit the partial flute and the cut side of the Plug sealed with aluminum foil tape.

HILTI CONSTRUCTION CHEMICALS, DIV OF HILTI INC — CFS-TTS MD P 1.5, CFS-TTS MD P2, CFS-TTS MD P3 Firestop Top Track Plug

* Indicates such products shall bear the UL or cUL Certification Mark for jurisdictions employing the UL or cUL Certification (such as Canada), respectively.

