

UL/cUL SYSTEM NO. W-L-7188

SUPPORT MEMBER THROUGH GYPSUM WALL ASSEMBLY

F-RATING = 1-HR. OR 2-HR.

T-RATING = 0-HR.

L-RATING AT AMBIENT = LESS THAN 1 CFM / SQ FT

L-RATING AT 400°F = LESS THAN 1 CFM / SQ FT

WL7188b.011415

FRONT VIEW

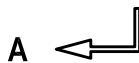
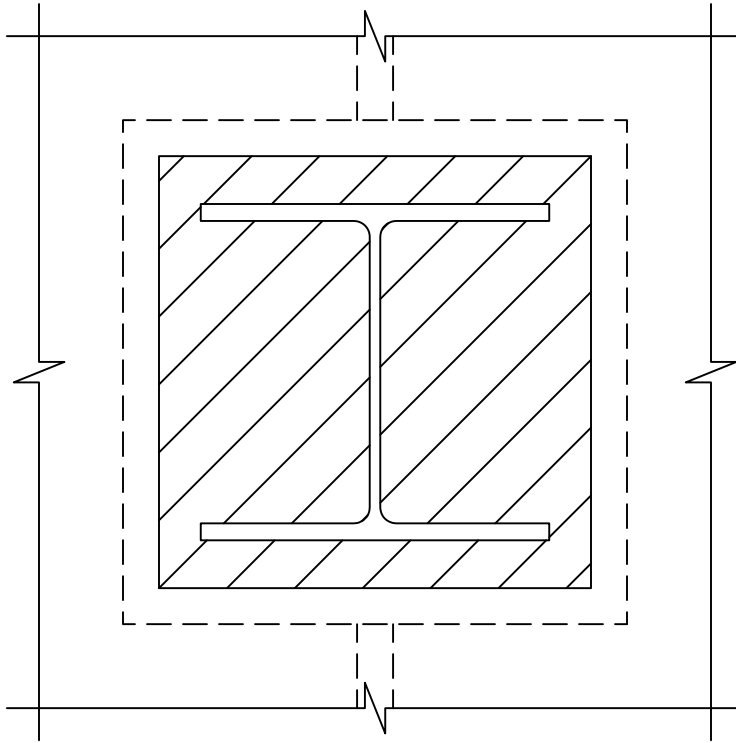
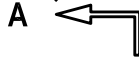

SECTION A-A

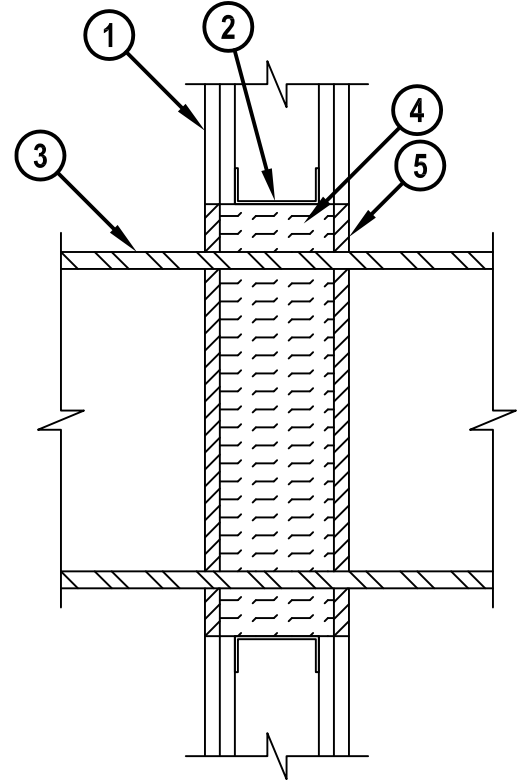

1. GYPSUM WALL ASSEMBLY (UL/cUL CLASSIFIED U400 OR V400 SERIES) (1-HR. OR 2-HR. FIRE-RATING) (2-HR. SHOWN) TO INCLUDE THE FOLLOWING CONSTRUCTION FEATURES :
 - A. STEEL STUDS TO BE MINIMUM 3-1/2" WIDE (SPACED MAXIMUM 24" OC).
 - B. NOMINAL 5/8" THICK GYPSUM WALLBOARD. TYPE, NUMBER OF LAYERS, AND SHEET ORIENTATION AS SPECIFIED IN THE INDIVIDUAL UL DESIGN.
2. OPENING TO BE FRAMED OUT WITH ADDITIONAL FRAMING MEMBERS.
3. STEEL I-BEAM SERVICE SUPPORT (MAXIMUM SIZE : W14x90).
4. MINERAL WOOL (MIN. 4 PCF DENSITY) TIGHTLY PACKED, RECESSED TO ACCOMMODATE SEALANT.
5. MINIMUM 5/8" DEPTH HILTI FS-ONE MAX OR FS-ONE INTUMESCENT FIRESTOP SEALANT.

NOTES : 1. MAXIMUM SIZE OF OPENING = 324 SQ. IN., WITH A MAXIMUM DIMENSION OF 18".
2. ANNULAR SPACE = MINIMUM 1/2", MAXIMUM 3".



Hilti Firestop Systems

HILTI, Inc.
Tulsa, Oklahoma USA (800) 879-8000

Sheet	1 of 1
Scale	1/8" = 1"
Date	Jan. 14, 2015

Drawing No.

**WL
7188b**

Saving Lives through Innovation and Education