

FIRE-RATED JOINT THROUGH CONCRETE FLOOR ASSEMBLY

F-RATING = 3-HR.

CLASS II MOVEMENT CAPABILITES - 14% COMPRESSION OR EXTENSION

TOP VIEW

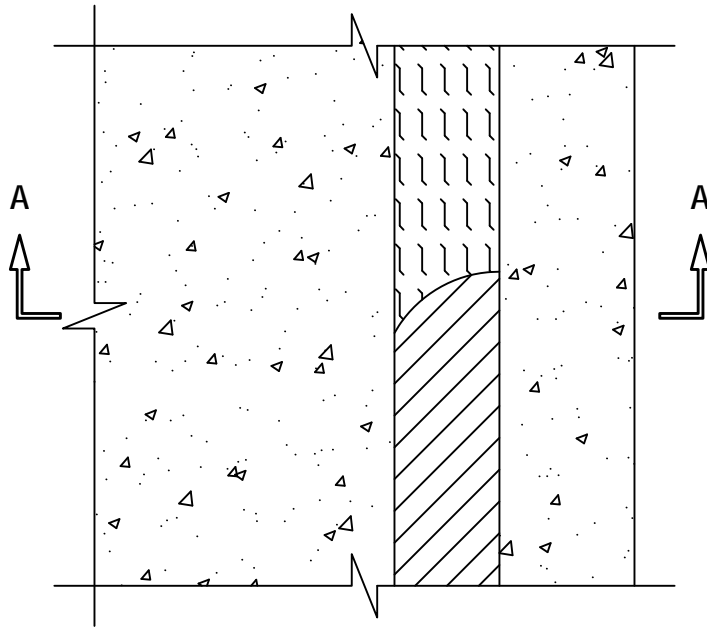

SECTION A-A

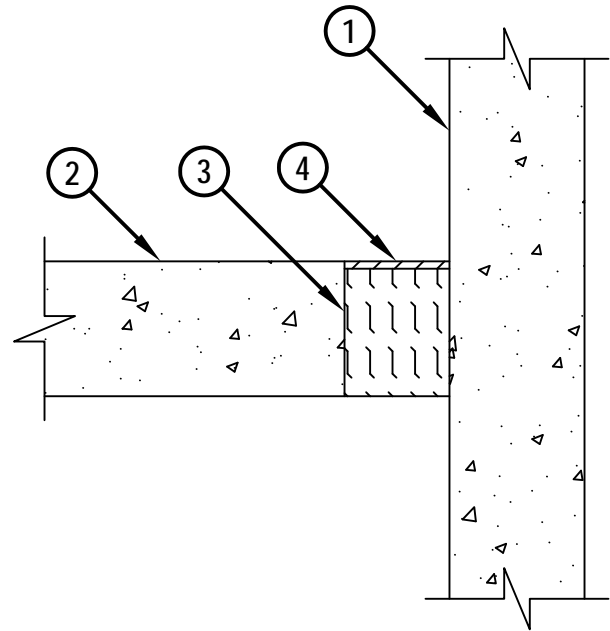

FWD1011g.021414

1. CONCRETE WALL ASSEMBLY (3-HR. FIRE-RATING) :
 - A. LIGHTWEIGHT OR NORMAL WEIGHT CONCRETE WALL (MINIMUM 4-1/2" THICK).
 - B. ANY UL/cUL CLASSIFIED CONCRETE BLOCK WALL.
2. LIGHTWEIGHT OR NORMAL WEIGHT CONCRETE FLOOR (MINIMUM 4-1/2" THICK) (3-HR. FIRE-RATING).
3. MINIMUM 4-1/4" THICKNESS MINERAL WOOL SAFING (MIN. 4 PCF DENSITY) COMPRESSED MINIMUM 42%.
4. MINIMUM 1/4" DEPTH HILTI CFS-S SIL GG FIRESTOP SILICONE SEALANT, HILTI CP 601S ELASTOMERIC FIRESTOP SEALANT, OR HILTI CFS-S SIL SL FIRESTOP SILICONE SEALANT.

NOTE : MAXIMUM WIDTH OF JOINT = 3-1/2".



HILTI, Inc.
Tulsa, Oklahoma USA (800) 879-8000

Sheet	1 of 1
Scale	5/32" = 1"
Date	Feb. 14, 2014

Drawing No.
**FWD
1011g**