



Classified by
Underwriters Laboratories, Inc.
to UL 1479 and CAN/ULC-S115

System No. C-AJ-5069

CAJ 5069

ANSI/UL1479 (ASTM E814)	CAN/ULC S115
F Rating — 2 Hr	F Rating — 2 Hr
T Ratings — 0 & 1 Hr (See Item 4)	T Ratings — 0 & 1 Hr (See Item 4)
	FH Rating — 2 Hr
	T Ratings — 0 & 1 Hr (See Item 4)

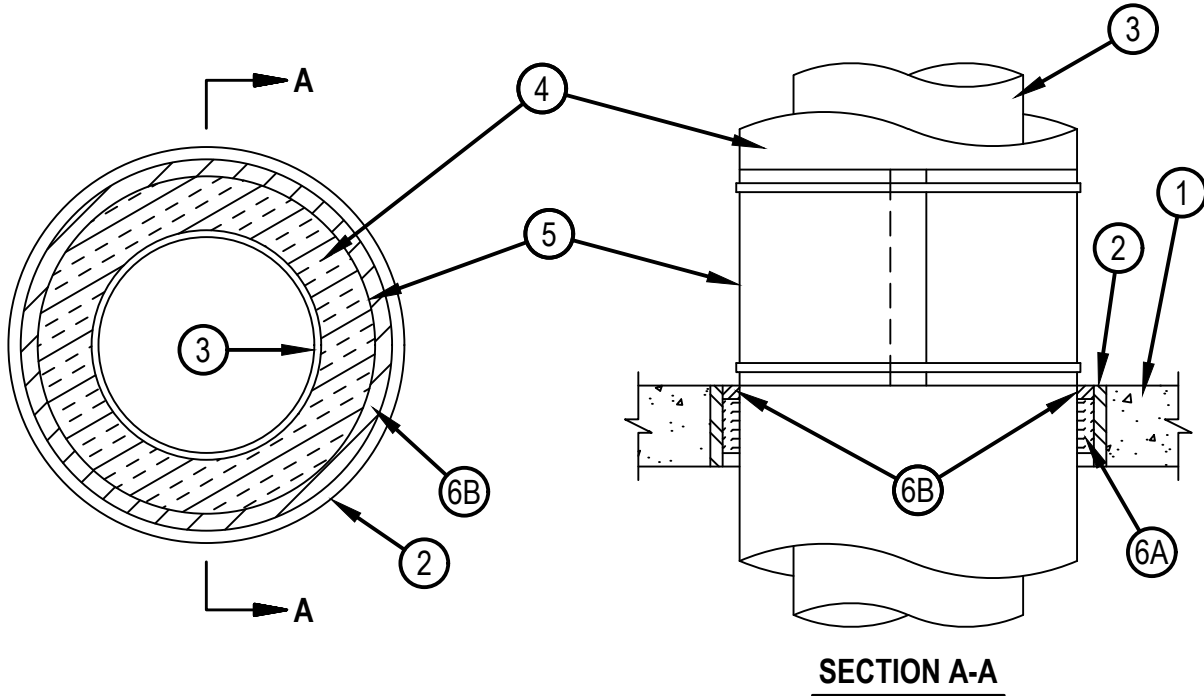

1. Floor or Wall Assembly — Min 4-1/2 in. (114 mm) thick reinforced lightweight or normal weight (100-150 pcf or 1600-2400 kg/m³) concrete. Floor assembly may also be constructed of any 6 in. (152 mm) thick UL Classified hollow-core Precast Concrete Units*. Wall may also be constructed of any UL Classified Concrete Blocks*. Max diam of opening is 22 in. (559 mm) except that for hollow-core precast concrete unit floors, max diameter of opening is 7 in. (178 mm).
See Concrete Blocks (CAZT) category and Precast Concrete Units CFTV) categories in the Fire Resistance Directory for names of manufacturers.
2. Metallic Sleeve — (Optional) — Nom 22 in. (559 mm) diam (or smaller) Schedule 40 steel pipe cast or grouted into floor or wall assembly, flush with floor or wall surfaces.
3. Through Penetrants — One metallic pipe or tubing to be positioned within the firestop system. Pipe or tubing to be rigidly supported on both sides of floor or wall assembly. The following types and sizes of metallic pipes or tubing may be used:
 - A. Steel Pipe — Nom 12 in. (305 mm) diam (or smaller) Schedule 40 (or heavier) steel pipe.
 - B. Copper Tubing — Nom 6 in. (152 mm) diam (or smaller) Type L (or heavier) copper tubing.
 - C. Copper Pipe — Nom 6 in. (152 mm) diam (or smaller) Regular (or heavier) copper pipe.



Hilti Firestop Systems

Reproduced by HILTI, Inc. Courtesy of
Underwriters Laboratories, Inc.
October 27, 2017

System No. C-AJ-5069

4. Pipe Covering Materials* — Cellular Glass Insulation — Nom 1-1/2 in. to 3 in. (38 to 76 mm) thick cellular glass pipe insulation sized to the outside diam of the steel pipe or tube and installed in accordance with the manufacturer's instructions. T, FT and FTH Ratings are 0 hr when nom thickness of pipe insulation is less than 3 in. (76 mm). T Rating is 1 hr when nom 3 in. (76 mm) thick pipe insulation is used. The annular space shall be min 3/4 in. (19 mm) to max 3 in. (76 mm).
5. Metal Jacket — Min 12 in. (305 mm) long jacket formed of min 0.010 in. (0.254 mm) thick steel or aluminum sheet cut to wrap tightly around the pipe insulation with a min 2 in. (51 mm) lap. Jacket secured with min 1/2 in. (13 mm) wide stainless steel hose clamps or bands located within 2 in. (51 mm) of each end of the jacket and spaced a max of 10 in. (254 mm) OC. Jacket to be installed with abutting surface of sealant (Item 6B) on top of floor or both surfaces of wall.
6. Firestop System — The firestop system shall consist of the following:
 - A. Packing Material — Min 3 in. (76 mm) thickness of min 4.0 pcf (64 kg/m³) mineral wool batt insulation firmly packed into opening as a permanent form. Packing material to be recessed from top surface of floor or from both surfaces of wall as required to accommodate the required thickness of fill material. In hollow-core precast concrete unit floors, an additional min 1 in. (25 mm) thickness of packing material shall be tightly packed within annular space flush with bottom surface of floor.
 - B. Fill, Void or Cavity Material* — Sealant — Min 3/4 in. (19 mm) thickness of fill material applied within the annulus, flush with the top surface of the floor or with both surfaces of the wall.
HILTI CONSTRUCTION CHEMICALS, DIV OF HILTI INC — FS-One Sealant or FS-ONE MAX Intumescent Sealant

* Indicates such products shall bear the UL or cUL Certification Mark for jurisdictions employing the UL or cUL Certification (such as Canada), respectively.



Hilti Firestop Systems

Reproduced by HILTI, Inc. Courtesy of
Underwriters Laboratories, Inc.
October 27, 2017