



Classified by
Underwriters Laboratories, Inc.
to UL 1479 and CAN/ULC-S115

System No. W-J-5213

WJ 5213

ANSI/UL1479 (ASTM E814)	CAN/ULC S115
F Rating — 1 or 2 Hr (See Item 1)	F Rating — 1 or 2 Hr (See Item 1)
T Rating — 1 or 2 Hr (See Item 1)	FT Rating — 1 or 2 Hr (See Item 1)
L Rating at Ambient — Less Than 1 CFM/Sq Ft	FH Rating — 1 or 2 Hr (See Item 1)
L Rating at 400°F — Less Than 1 CFM/Sq Ft	FTH Rating — 1 or 2 Hr (See Item 1)
	L Rating At Ambient — Less Than 5.1 L/s/m ²
	L Rating At 204°C — Less Than 5.1 L/s/m ²

FRONT VIEW

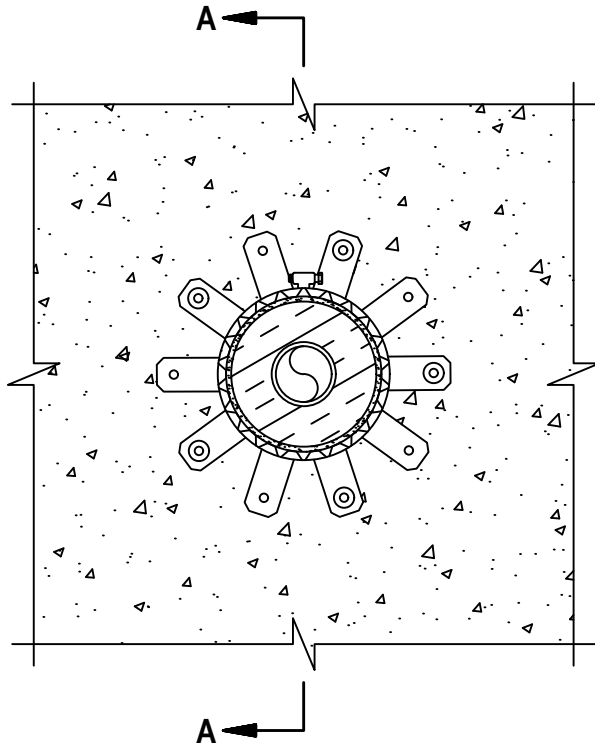

SECTION A-A

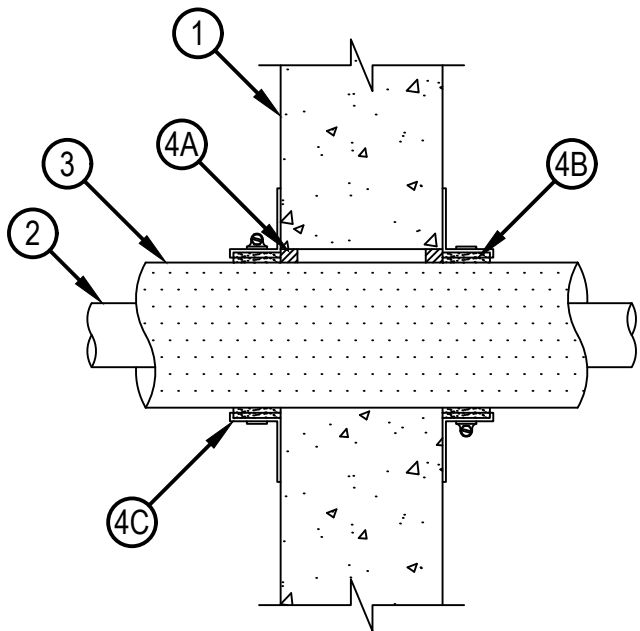

Reproduced by HILTI, Inc. Courtesy of
Underwriters Laboratories, Inc.
October 3, 2022

System No. W-J-5213

WJ 5213

1. Wall Assembly —Min 4-7/8 in. (124 mm) and 6-1/8 in. (156 mm) thick normal weight or lightweight (100-150 pcf or 1600-2400 kg/m³) concrete for 1 and 2 hour rated assemblies, respectively. Wall may also be constructed of any UL Classified Concrete Blocks*. Max diam of opening is 6 in. (153 mm).

See Concrete Blocks (CAZT) category in the Fire Resistance Directory for names of manufacturers.

The F, T, FT, FH, FTH Ratings are 1 and 2 hr for 1 and 2 hr rated assemblies, respectively.

2. Through Penetrants —One pipe or tubing to be centered within the firestop system. Pipe to be rigidly supported on both sides of wall. The following types and sizes of pipes may be used:

A. Copper Tube —Nom 2 in. (51 mm) diam (or smaller) Type L (or heavier) copper tube.

B. Copper Pipe —Nom 2 in. (51 mm) diam (or smaller) Regular (or heavier) copper pipe.

3. Tube Insulation —Plastics+ —Max 1-1/2 in. (38 mm) thick acrylonitrile butadiene/polyvinyl chloride (AB/PVC) flexible foam furnished in the form of tubing. The annular space shall be min 0 in. to max 1-1/4 in. (0 to 32 mm).

See Plastics+ (QMFZ2) category in the Recognized Component Directory for names of manufacturers. Any Recognized Component tube insulation material meeting the above specifications and having a UL 94 Flammability Classification of 94-5VA may be used.

4. Firestop System —The firestop system shall consist of the following:

A. Fill, Void or Cavity Material* - Sealant —Min 5/8 in. (16 mm) thickness of fill material applied within the annulus, flush with both surfaces of wall.

HILTI CONSTRUCTION CHEMICALS, DIV OF HILTI INC — FS-ONE Sealant or FS-ONE MAX Intumescent Sealant

B. Fill, Void or Cavity Material* — Wrap Strip —Nom 3/16 in. (5 mm) thick by 1-3/4 in. (44 mm) wide intumescent wrap strip. Layers individually wrapped around the through-penetrant with the ends butted and held in place with tape. Butted ends in successive layers shall be offset. Each wrap strip layer is to be installed flush with both surfaces of wall. Wrap strips are installed on each surface of the wall.

Product Designation	Max Pipe Size, in. (mm)	Number of Layers
CP648-E W45/1-3/4"	2 (51)	2

HILTI CONSTRUCTION CHEMICALS, DIV OF HILTI INC — CP-648E Wrap Strip

C. Steel Collar —Steel collar fabricated from coils of precut min 0.016 in. (0.4 mm) thick (No. 28 gauge) galv steel available from fill material manufacturer. Collar shall be nom 1-3/4 in. (44 mm) deep with 1 in. (25 mm) wide by 2 in. (51 mm) long anchor tabs on 1-3/4 in. (44 mm) centers for securement to both surfaces of wall. In addition, collars contain retainer tabs 1/2 in. (13 mm) wide by 3/16 in. (5 mm) long, located opposite the anchor tabs. Collar shall be tightly wrapped over the wrap strip, overlapping min 1 in. (25 mm) at seam and compressed with a 1/2 in. (13 mm.) wide by min 0.028 in. (0.7 mm) thick stainless-steel band at collar mid-height. The retainer tabs are folded 90 deg towards the pipe to maintain the annular space around the pipe and to retain the wrap strip. Each tab of collar secured to surface of wall by means of nom 1-1/2 in. (38 mm) long steel masonry screws or anchors in conjunction with 3/4 in. (19 mm) diam steel fender washers.

* Indicates such products shall bear the UL or cUL Certification Mark for jurisdictions employing the UL or cUL Certification (such as Canada), respectively.



Hilti Firestop Systems

Reproduced by HILTI, Inc. Courtesy of
Underwriters Laboratories, Inc.
October 3, 2022