

MARK	ITEM NO.	DESCRIPTION	QTY.
1	2268365	MT-70 OC	1
2	2272101	MT-B-GS O4U OC	1
3	2210261	ANCHOR KB-TZ2 1/2" x 4-1/2" SS304	4
4	2272084	MT-TFB OC	6
5	2273697	MT-EC-70	1

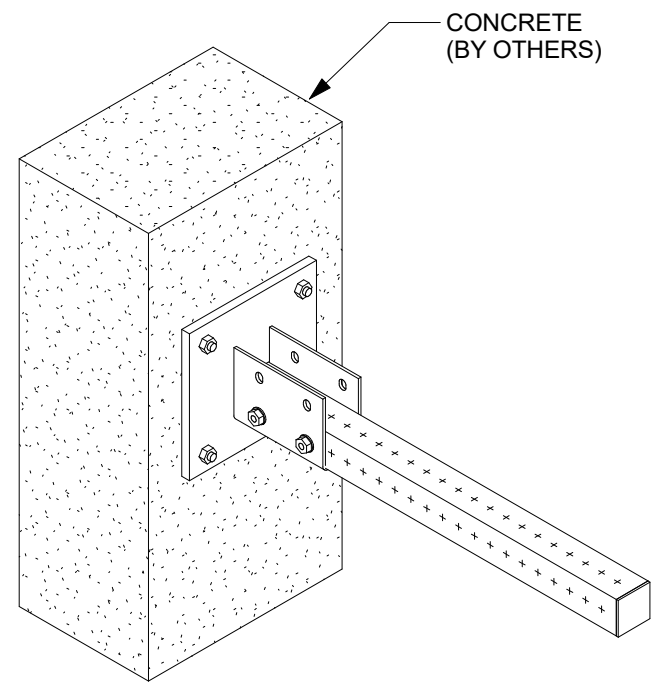

1 ISOMETRIC
N.T.S.

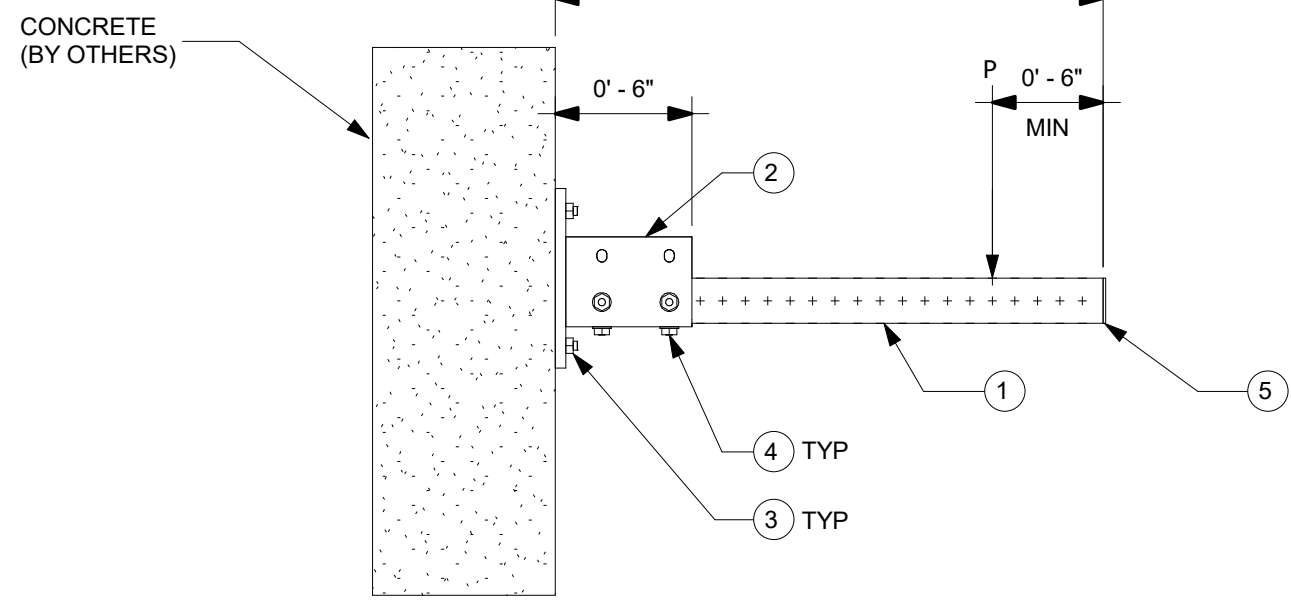

2 ELEVATION
N.T.S.

NOTE(S):

A. THE TYPICAL SUPPORT IS LOAD RATED AND DIMENSIONALLY LIMITED BASED ON DESIGN METHODOLOGY AND GENERIC NON-PROJECT SPECIFIC ASSUMPTIONS SET FORTH IN PROFIS MODULAR SUPPORTS ENGINEERING SOFTWARE VERSION 1.3. THE ENGINEER OF RECORD SHALL EVALUATE THIS TYPICAL SUPPORT TO DETERMINE ITS SUITABILITY FOR THE ACTUAL PROJECT SPECIFIC DESIGN CRITERIA AND REQUIREMENTS.

B. THE EVALUATION OF EXISTING STRUCTURE IS OUTSIDE OF THE TYPICAL DESIGN SCOPE AND SHALL BE PERFORMED BY THE ENGINEER OF RECORD.

C. TYPICAL SUPPORT DESIGN IS BASED ON INTERNATIONAL BUILDING CODE (IBC) 2018. SEE TABLE-A FOR ALLOWABLE STRENGTH DESIGN LOADS (STATIC U.N.O.); GOVERNING LATERAL LOADS NOTED IN THE ALLOWABLE LOAD TABLE IS MAXIMUM OF 30% OF DEAD LOAD.

D. ALL LOADS ASSUMED TO ACT ON THE SUPPORT, NO ECCENTRICITY CONSIDERED

E. MAXIMUM ALLOWABLE LOADS NOTED IN TABLE-A ARE BASED ON THE GOVERNING COMBINATION OF VERTICAL LOAD WITH TRANSVERSE LOAD OR VERTICAL LOAD WITH LONGITUDINAL LOAD. A SEPARATE ANALYSIS MUST BE PERFORMED WHEN TRANSVERSE AND LONGITUDINAL LOAD OCCURS SIMULTANEOUSLY.

F. REFER TO HILTI INSTRUCTION FOR USE SHEET FOR REQUIRED INSTALLATION INFORMATION. THREAD FORMING BOLT MAY BE INSTALLED USING A TORQUE WRENCH OR SI-AT-A22 PER INSTRUCTION FOR USE.

G. SEE BOM FOR KWIK BOLT-TZ2 ANCHOR BOLT. FOR 1/2" DIA. HILTI KWIK BOLT-TZ2 USE MIN. 3-1/4" EFFECTIVE EMBEDMENT. FOR 5/8" DIA. KWIK BOLT-TZ2 USE 3-1/4" MIN. EFFECTIVE EMBEDMENT. INSTALL ANCHOR PER ESR-4266 AND HILTI'S INSTRUCTIONS FOR USE AND RECOMMENDATIONS. MIN. CONCRETE COMPRESSIVE STRENGTH F'C=3000 PSI, MIN. CONCRETE EDGE DISTANCE = 6", AND MIN. CONCRETE THICKNESS = 6".

H. CONCRETE ANCHORS NOTED IN THE BILL OF MATERIAL ARE DESIGNED ONLY FOR WIND LATERAL LOADING. ENGINEER OF RECORD TO VERIFY ADEQUACY OF ANCHOR WHEN TYPICAL IS BEING USED FOR SEISMIC LATERAL LOADING.

		TABLE A	
ALLOWABLE LOADS, lbs	Max W, in	18	24
	Vertical (P)	725	475
	Transverse	218	142
	Longitudinal	218	142

		REVISION HISTORY			
NO:	DESCRIPTION:			DATE:	
B	ISSUE FOR REVIEW			02/18/2021	
C	ISSUE FOR BU USE			07/06/2021	
D	ANCHOR NOTE AND BOM MODIFICATION FOR ANCHOR			03/22/2022	

PROJECT NAME: CANTILEVER MT70 C 001

PROJECT DESCRIPTION: CANTILEVER MT70 C 001

DRAWN:	CHECKED:
GAB	IDP
DESIGNED:	REVIEWED:
JDR	BVD
PAPER SIZE: ANSI B	
PROJECT NUMBER: CT7C1 - 1	
PROJECT	JOB
SHEET	

MARK	ITEM NO.	DESCRIPTION	QTY.
1	2268365	MT-70 OC	1
2	2272101	MT-B-GS O4U OC	1
3	2194341	X-BT-MR W10/15 SN 8	4
4	2272084	MT-TFB OC	6
5	2273697	MT-EC-70	1

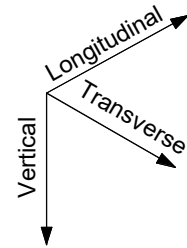
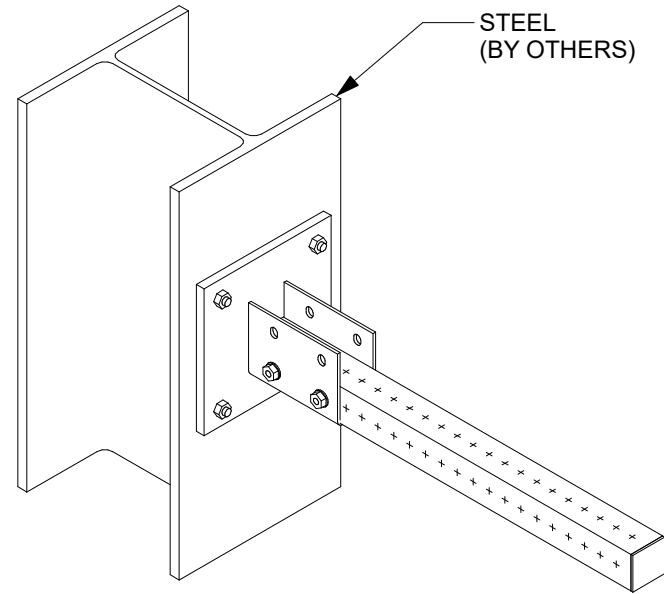

STEEL (BY OTHERS)

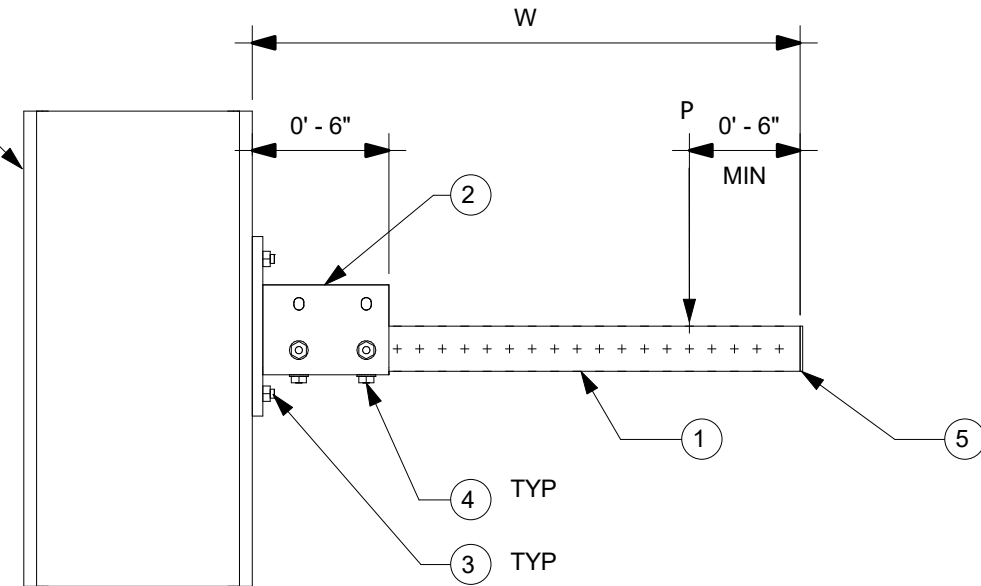

1 ISOMETRIC
N.T.S.

2 ELEVATION
N.T.S.

NOTE(S):

A. THE TYPICAL SUPPORT IS LOAD RATED AND DIMENSIONALLY LIMITED BASED ON DESIGN METHODOLOGY AND GENERIC NON-PROJECT SPECIFIC ASSUMPTIONS SET FORTH IN PROFIS MODULAR SUPPORTS ENGINEERING SOFTWARE VERSION 1.3. THE ENGINEER OF RECORD SHALL EVALUATE THIS TYPICAL SUPPORT TO DETERMINE ITS SUITABILITY FOR THE ACTUAL PROJECT SPECIFIC DESIGN CRITERIA AND REQUIREMENTS.

B. THE EVALUATION OF EXISTING STRUCTURE IS OUTSIDE OF THE TYPICAL DESIGN SCOPE AND SHALL BE PERFORMED BY THE ENGINEER OF RECORD.

C. TYPICAL SUPPORT DESIGN IS BASED ON INTERNATIONAL BUILDING CODE (IBC) 2018. SEE TABLE-A FOR ALLOWABLE STRENGTH DESIGN LOADS (STATIC U.N.O.); GOVERNING LATERAL LOADS NOTED IN THE ALLOWABLE LOAD TABLE IS MAXIMUM OF 30% OF DEAD LOAD.

D. ALL LOADS ASSUMED TO ACT ON THE SUPPORT, NO ECCENTRICITY CONSIDERED.

E. MAXIMUM ALLOWABLE LOADS NOTED IN TABLE-A ARE BASED ON THE GOVERNING COMBINATION OF VERTICAL LOAD WITH TRANSVERSE LOAD OR VERTICAL LOAD WITH LONGITUDINAL LOAD. A SEPARATE ANALYSIS MUST BE PERFORMED WHEN TRANSVERSE AND LONGITUDINAL LOAD OCCURS SIMULTANEOUSLY.

F. REFER TO HILTI INSTRUCTION FOR USE SHEET FOR REQUIRED INSTALLATION INFORMATION. THREAD FORMING BOLT MAY BE INSTALLED USING A TORQUE WRENCH OR SI-AT-A22 PER INSTRUCTION FOR USE.

G. X-BT REQUIREMENT: MIN. STEEL BASE MATERIAL THICKNESS SHALL BE 5/16". MIN EDGE DISTANCE SHALL BE 3/8". MIN YIELD STRENGTH OF STEEL SHALL BE FY=36KSI.

H. MINIMUM 8" FLANGE WIDTH REQUIRED.

	Max W, in	18	24
ALLOWABLE LOADS, lbs	Vertical (P)	550	350
	Transverse	165	105
	Longitudinal	165	105

REVISION HISTORY		
NO:	DESCRIPTION:	DATE:
A	ISSUE FOR REVIEW	08/19/2020
B	ISSUE FOR REVIEW	12/14/2020
C	ISSUE FOR REVIEW - NOTE MODIFICATIONS AND DIM CALLOUTS	05/28/2021

PROJECT NAME: **CANTILEVER MT70 S 001**



PROJECT DESCRIPTION: **CANTILEVER MT70 S 001**

DRAWN:	CHECKED:	DESIGNED:	REVIEWED:
GAB	BAP	JDR	BVD
PAPER SIZE: ANSI B		PROJECT NUMBER: CT7S1 - 1	

MARK	ITEM NO.	DESCRIPTION	QTY.
1	2268367	MT-80 OC	1
2	2272101	MT-B-GS O4U OC	1
3	2210261	ANCHOR KB-TZ2 1/2" x 4-1/2" SS304	4
4	2272084	MT-TFB OC	10
5	2273698	MT-EC-80	1

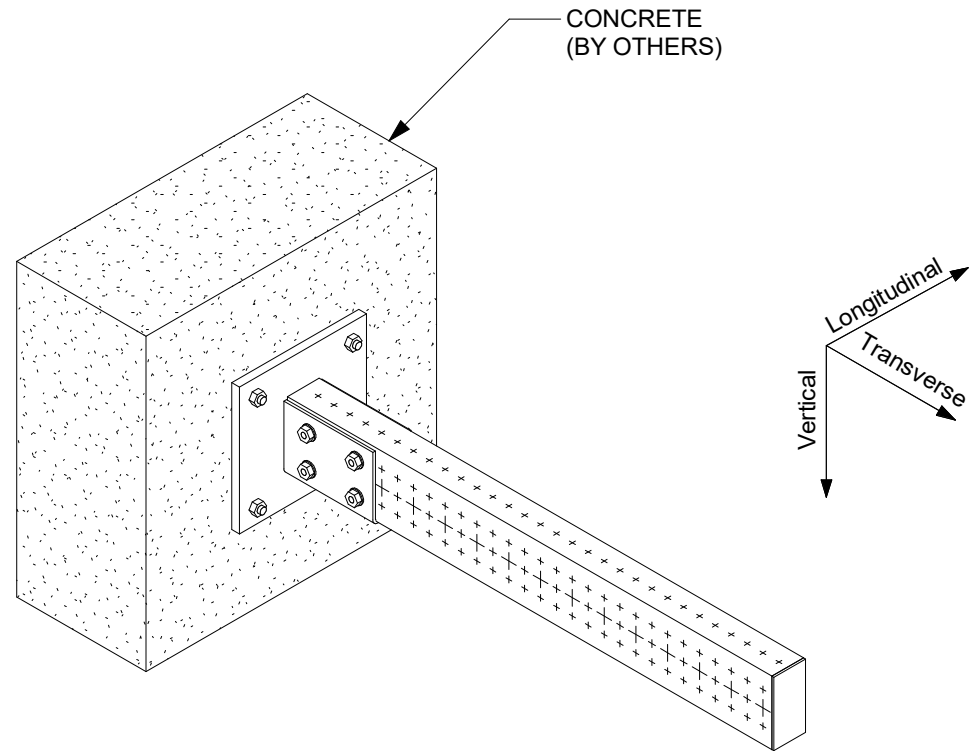

1 ISOMETRIC
N.T.S.

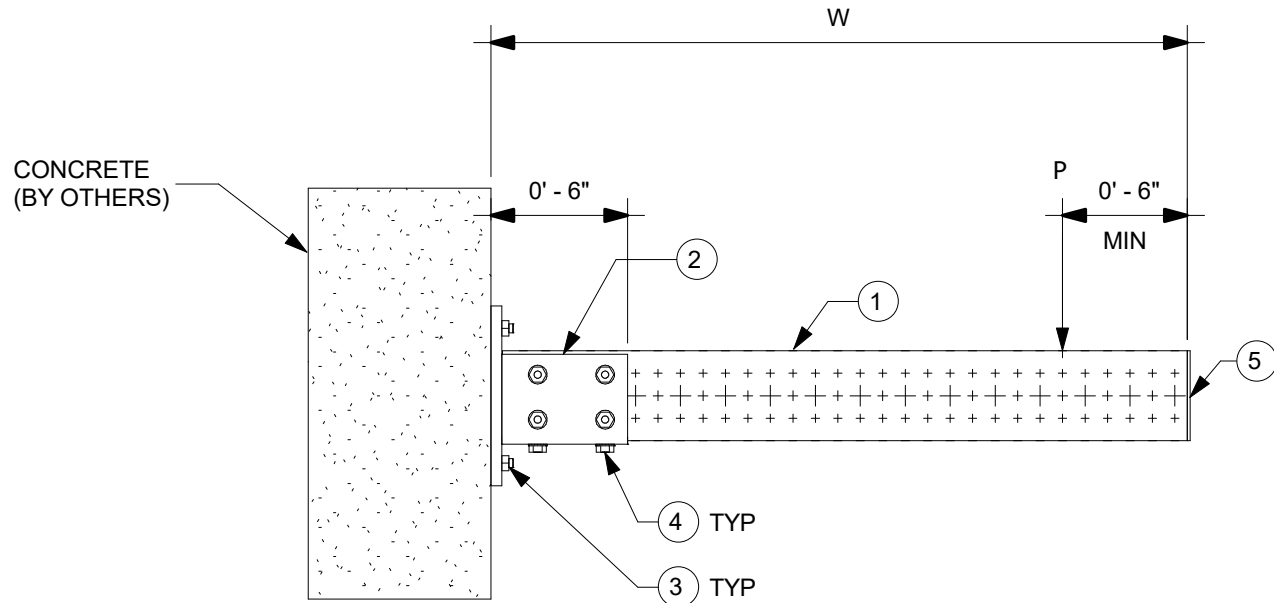

2 ELEVATION
N.T.S.

NOTE(S):

A. THE TYPICAL SUPPORT IS LOAD RATED AND DIMENSIONALLY LIMITED BASED ON DESIGN METHODOLOGY AND GENERIC NON-PROJECT SPECIFIC ASSUMPTIONS SET FORTH IN PROFIS MODULAR SUPPORTS ENGINEERING SOFTWARE VERSION 1.3. THE ENGINEER OF RECORD SHALL EVALUATE THIS TYPICAL SUPPORT TO DETERMINE ITS SUITABILITY FOR THE ACTUAL PROJECT SPECIFIC DESIGN CRITERIA AND REQUIREMENTS.

B. THE EVALUATION OF EXISTING STRUCTURE IS OUTSIDE OF THE TYPICAL DESIGN SCOPE AND SHALL BE PERFORMED BY THE ENGINEER OF RECORD.

C. TYPICAL SUPPORT DESIGN IS BASED ON INTERNATIONAL BUILDING CODE (IBC) 2018. SEE TABLE-A FOR ALLOWABLE STRENGTH DESIGN LOADS (STATIC U.N.O.); GOVERNING LATERAL LOADS NOTED IN THE ALLOWABLE LOAD TABLE IS MAXIMUM OF 30% OF DEAD LOAD.

D. ALL LOADS ASSUMED TO ACT ON THE SUPPORT, NO ECCENTRICITY CONSIDERED

E. MAXIMUM ALLOWABLE LOADS NOTED IN TABLE-A ARE BASED ON THE GOVERNING COMBINATION OF VERTICAL LOAD WITH TRANSVERSE LOAD OR VERTICAL LOAD WITH LONGITUDINAL LOAD. A SEPARATE ANALYSIS MUST BE PERFORMED WHEN TRANSVERSE AND LONGITUDINAL LOAD OCCURS SIMULTANEOUSLY.

F. REFER TO HILTI INSTRUCTION FOR USE SHEET FOR REQUIRED INSTALLATION INFORMATION. THREAD FORMING BOLT MAY BE INSTALLED USING A TORQUE WRENCH OR SI-AT-A22 PER INSTRUCTION FOR USE.

G. SEE BOM FOR KWIK BOLT-TZ2 ANCHOR BOLT. FOR 1/2" DIA. HILTI KWIK BOLT-TZ2 USE MIN. 3-1/4" EFFECTIVE EMBEDMENT. FOR 5/8" DIA. KWIK BOLT-TZ2 USE 3-1/4" MIN. EFFECTIVE EMBEDMENT. INSTALL ANCHOR PER ESR-4266 AND HILTI'S INSTRUCTIONS FOR USE AND RECOMMENDATIONS. MIN. CONCRETE COMPRESSIVE STRENGTH F'C=3000 PSI, MIN. CONCRETE EDGE DISTANCE = 6", AND MIN. CONCRETE THICKNESS = 6".

H. CONCRETE ANCHORS NOTED IN THE BILL OF MATERIAL ARE DESIGNED ONLY FOR WIND LATERAL LOADING. ENGINEER OF RECORD TO VERIFY ADEQUACY OF ANCHOR WHEN TYPICAL IS BEING USED FOR SEISMIC LATERAL LOADING.

		TABLE A	
ALLOWABLE LOADS, lbs	Max W, in	18	24
	Vertical (P)	1400	1000
	Transverse	420	300
	Longitudinal	420	300

REVISION HISTORY		
NO.	DESCRIPTION:	DATE:
B	ISSUE FOR REVIEW - UPDATED DIMENSIONS	03/03/2021
C	ISSUE FOR BU USE	07/06/2021
D	ANCHOR NOTE AND BOM MODIFICATION FOR ANCHOR	03/22/2022

PROJECT NAME: CANTILEVER MT80 C 001

PROJECT DESCRIPTION: CANTILEVER MT80 C 001

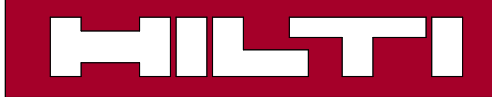

DRAWN:	CHECKED:	DESIGNED:	REVIEWED:
GAB	BAP	JDR	BVD
PAPER SIZE:	PROJECT NUMBER:		
ANSI B	PROJECT	JOB	SHEET
	- CT8C1 -		1

MARK	ITEM NO.	DESCRIPTION	QTY.
1	2268369	MT-90 OC	1
2	VARIES	MT-B-GXL S+ OC (SEE TABLE)	1
3	2272084	MT-TFB OC	18
4	387398	MI-SGC M16	4
5	2273699	MT-EC-90	1

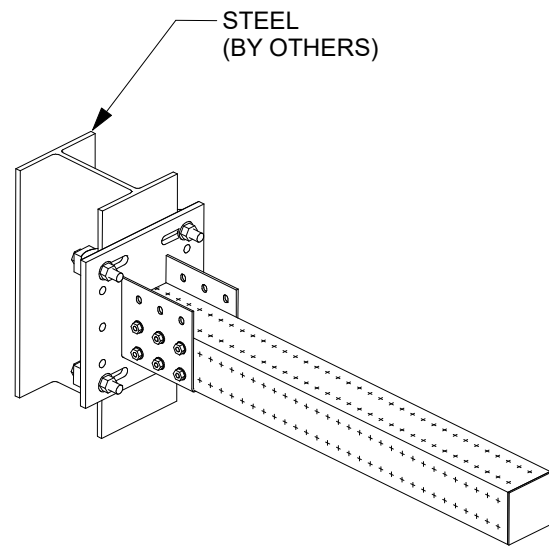

1 ISOMETRIC
N.T.S.

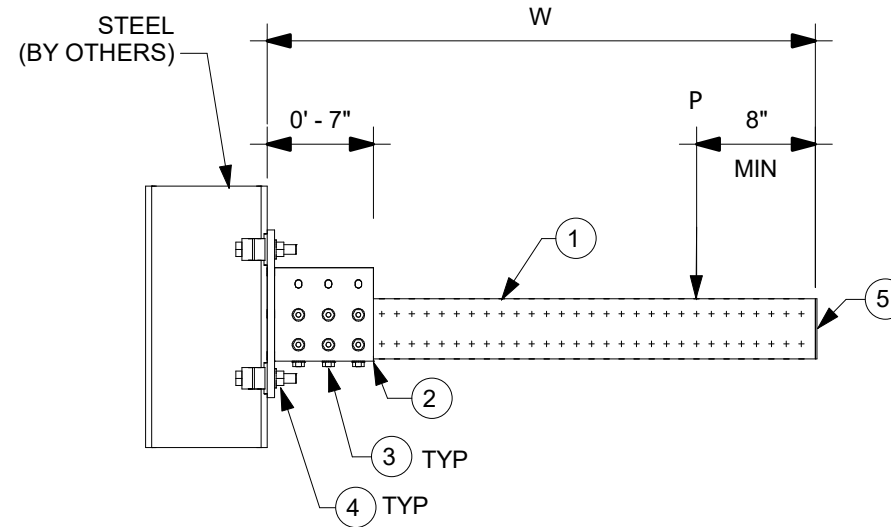
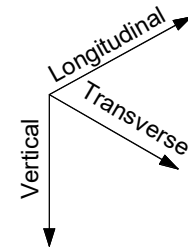

2 ELEVATION
N.T.S.

MT-B-GXL S+ OC		
+	'B' Width	Item No.
1	2.9 to 6.5	2272106
2	6.5 to 9.2	2272107
3	9.2 to 11.8	2272108

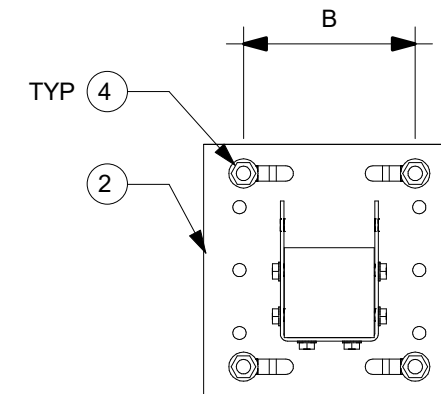

3 BASEPLATE DETAIL
N.T.S.

NOTE(S):

A. THE TYPICAL SUPPORT IS LOAD RATED AND DIMENSIONALLY LIMITED BASED ON DESIGN METHODOLOGY AND GENERIC NON-PROJECT SPECIFIC ASSUMPTIONS SET FORTH IN PROFIS MODULAR SUPPORTS ENGINEERING SOFTWARE VERSION 1.3. THE ENGINEER OF RECORD SHALL EVALUATE THIS TYPICAL SUPPORT TO DETERMINE ITS SUITABILITY FOR THE ACTUAL PROJECT SPECIFIC DESIGN CRITERIA AND REQUIREMENTS.

B. THE EVALUATION OF EXISTING STRUCTURE IS OUTSIDE OF THE TYPICAL DESIGN SCOPE AND SHALL BE PERFORMED BY THE ENGINEER OF RECORD.

C. TYPICAL SUPPORT DESIGN IS BASED ON INTERNATIONAL BUILDING CODE (IBC) 2018. SEE TABLE-A FOR ALLOWABLE STRENGTH DESIGN LOADS (STATIC U.N.O.); GOVERNING LATERAL LOADS NOTED IN THE ALLOWABLE LOAD TABLE IS MAXIMUM OF 30% OF DEAD LOAD.

D. ALL LOADS ASSUMED TO ACT ON THE SUPPORT, NO ECCENTRICITY CONSIDERED.

E. MAXIMUM ALLOWABLE LOADS NOTED IN TABLE-A ARE BASED ON THE GOVERNING COMBINATION OF VERTICAL LOAD WITH TRANSVERSE LOAD OR VERTICAL LOAD WITH LONGITUDINAL LOAD. A SEPARATE ANALYSIS MUST BE PERFORMED WHEN TRANSVERSE AND LONGITUDINAL LOAD OCCURS SIMULTANEOUSLY.

F. REFER TO HILTI INSTRUCTION FOR USE SHEET FOR REQUIRED INSTALLATION INFORMATION. THREAD FORMING BOLT MAY BE INSTALLED USING A TORQUE WRENCH OR SI-AT-A22 PER INSTRUCTION FOR USE.

TABLE A			
ALLOWABLE LOADS, lbs	Max W, in	36	48
	Vertical (P)	1100	800
	Transverse	330	240
	Longitudinal	330	240

All loading and design criteria supplied by customer is assumed accurate. Only the stated Design Assumptions were considered, and must be verified by the responsible Engineer of Record (EOR). The basis of Hilti component and connection design is the published data in the current Hilti Technical Guide, including material and cross-section properties, allowable load values, factors of safety, methods of calculation, and limiting factors. The EOR must verify suitability for any specific application, and the capacity of the supportive structure to receive the shown configuration and associated reaction loads. Modification to components and/or design may alter performance and must be evaluated by the EOR.

REVISION HISTORY		
NO.	DESCRIPTION:	DATE:
A	ISSUE FOR REVIEW	12/18/2020
B	NOTE MODIFICATIONS	01/29/2021
C	ISSUE FOR REVIEW - NOTE MODIFICATIONS AND DIM CALLOUTS	05/28/2021

PROJECT NAME:

CANTILEVER MT90 S 001

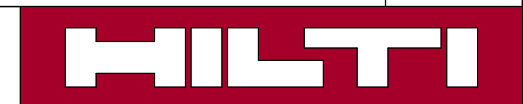

PROJECT DESCRIPTION:

CANTILEVER MT90 S 001

DRAWN:	CHECKED:	DESIGNED:	REVIEWED:
GAB	IDP	JDR	BVD
PAPER SIZE:		PROJECT NUMBER:	
ANSI B		PROJECT	JOB
		- CT9S1 -	
		SHEET	
		1	

MAR K	ITEM NO.	DESCRIPTION	QTY.
1	2268491	MT-100 OC	1
2	2272104	MT-B-GXL-O4 OC	1
3	2272084	MT-TFB OC	30
4	2210278	ANCHOR KB-TZ2 5/8" X 4-3/4" SS304	4
5	2273700	MT-EC-100	1

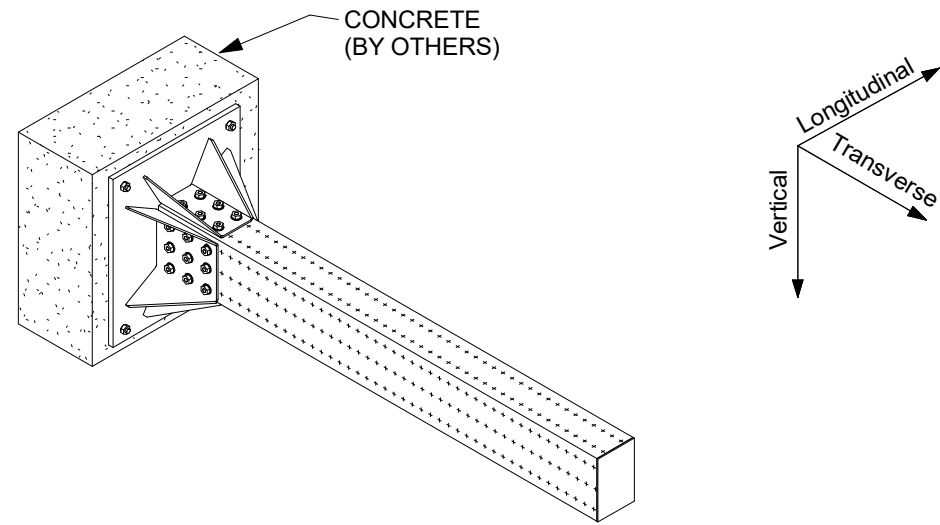

1 ISOMETRIC
N.T.S.

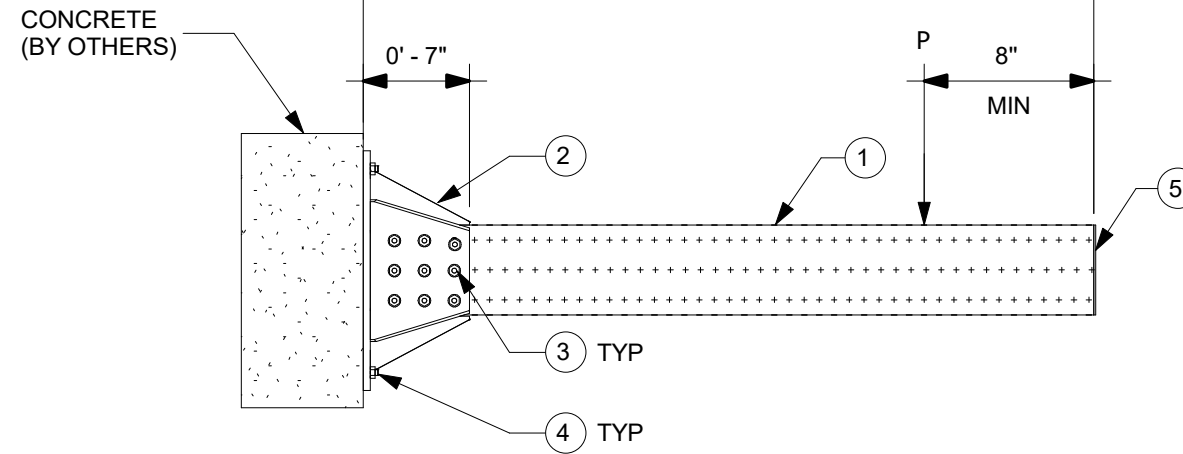

2 ELEVATION
N.T.S.

NOTE(S):

A. THE TYPICAL SUPPORT IS LOAD RATED AND DIMENSIONALLY LIMITED BASED ON DESIGN METHODOLOGY AND GENERIC NON-PROJECT SPECIFIC ASSUMPTIONS SET FORTH IN PROFIS MODULAR SUPPORTS ENGINEERING SOFTWARE VERSION 1.3. THE ENGINEER OF RECORD SHALL EVALUATE THIS TYPICAL SUPPORT TO DETERMINE ITS SUITABILITY FOR THE ACTUAL PROJECT SPECIFIC DESIGN CRITERIA AND REQUIREMENTS.

B. THE EVALUATION OF EXISTING STRUCTURE IS OUTSIDE OF THE TYPICAL DESIGN SCOPE AND SHALL BE PERFORMED BY THE ENGINEER OF RECORD.

C. TYPICAL SUPPORT DESIGN IS BASED ON INTERNATIONAL BUILDING CODE (IBC) 2018. SEE TABLE-A FOR ALLOWABLE STRENGTH DESIGN LOADS (STATIC U.N.O.); GOVERNING LATERAL LOADS NOTED IN THE ALLOWABLE LOAD TABLE IS MAXIMUM OF 30% OF DEAD LOAD.

D. ALL LOADS ASSUMED TO ACT ON THE SUPPORT, NO ECCENTRICITY CONSIDERED

E. MAXIMUM ALLOWABLE LOADS NOTED IN TABLE-A ARE BASED ON THE GOVERNING COMBINATION OF VERTICAL LOAD WITH TRANSVERSE LOAD OR VERTICAL LOAD WITH LONGITUDINAL LOAD. A SEPARATE ANALYSIS MUST BE PERFORMED WHEN TRANSVERSE AND LONGITUDINAL LOAD OCCURS SIMULTANEOUSLY.

F. REFER TO HILTI INSTRUCTION FOR USE SHEET FOR REQUIRED INSTALLATION INFORMATION. THREAD FORMING BOLT MAY BE INSTALLED USING A TORQUE WRENCH OR SI-AT-A22 PER INSTRUCTION FOR USE.

G. SEE BOM FOR KWIK BOLT-TZ2 ANCHOR BOLT. FOR 1/2" DIA. HILTI KWIK BOLT-TZ2 USE MIN. 3-1/4" EFFECTIVE EMBEDMENT. FOR 5/8" DIA. KWIK BOLT-TZ2 USE 3-1/4" MIN. EFFECTIVE EMBEDMENT. INSTALL ANCHOR PER ESR-4266 AND HILTI'S INSTRUCTIONS FOR USE AND RECOMMENDATIONS. MIN. CONCRETE COMPRESSIVE STRENGTH F'C=3000 PSI, MIN. CONCRETE EDGE DISTANCE = 6", AND MIN. CONCRETE THICKNESS = 6".

H. CONCRETE ANCHORS NOTED IN THE BILL OF MATERIAL ARE DESIGNED ONLY FOR WIND LATERAL LOADING. ENGINEER OF RECORD TO VERIFY ADEQUACY OF ANCHOR WHEN TYPICAL IS BEING USED FOR SEISMIC LATERAL LOADING.

		TABLE A	
ALLOWABLE LOADS, lbs	Max W, in	36	48
	Vertical (P)	2700	1900
	Transverse	810	570
	Longitudinal	810	570

REVISION HISTORY		
NO:	DESCRIPTION:	DATE:
B	NOTE MODIFICATIONS	01/29/2021
C	ISSUE FOR BU USE	07/06/2021
D	ANCHOR NOTE AND BOM MODIFICATION FOR ANCHOR	03/21/2022

PROJECT NAME:					
CANTILEVER MT100 C 001					
PROJECT DESCRIPTION:		DRAWN:	CHECKED:	DESIGNED:	REVIEWED:
CANTILEVER MT100 C 001		GAB	IDP	JDR	BVD
PAPER SIZE:		PROJECT NUMBER:			
ANSI B		PROJECT	JOB	SHEET	
		- CT1C1 -		1	

MARK	ITEM NO.	DESCRIPTION	QTY.
1	2268365	MT-70 OC	2
2	2268365	MT-70 OC	1
3	2272101	MT-B-GS O4U OC	2
4	2272073	MT-C-GSP L OC	4
5	2272084	MT-TFB OC	28
6	2210261	ANCHOR KB-TZ2 1/2" x 4-1/2" SS304	8
7	2273697	MT-EC-70	2

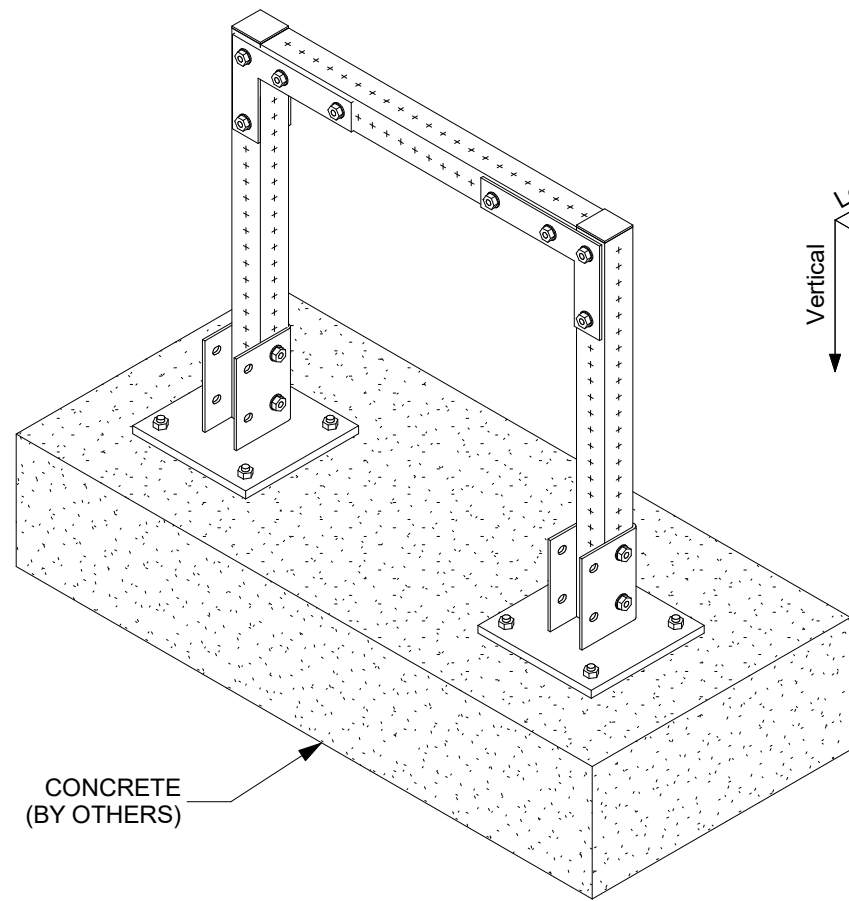

1 ISOMETRIC
N.T.S.

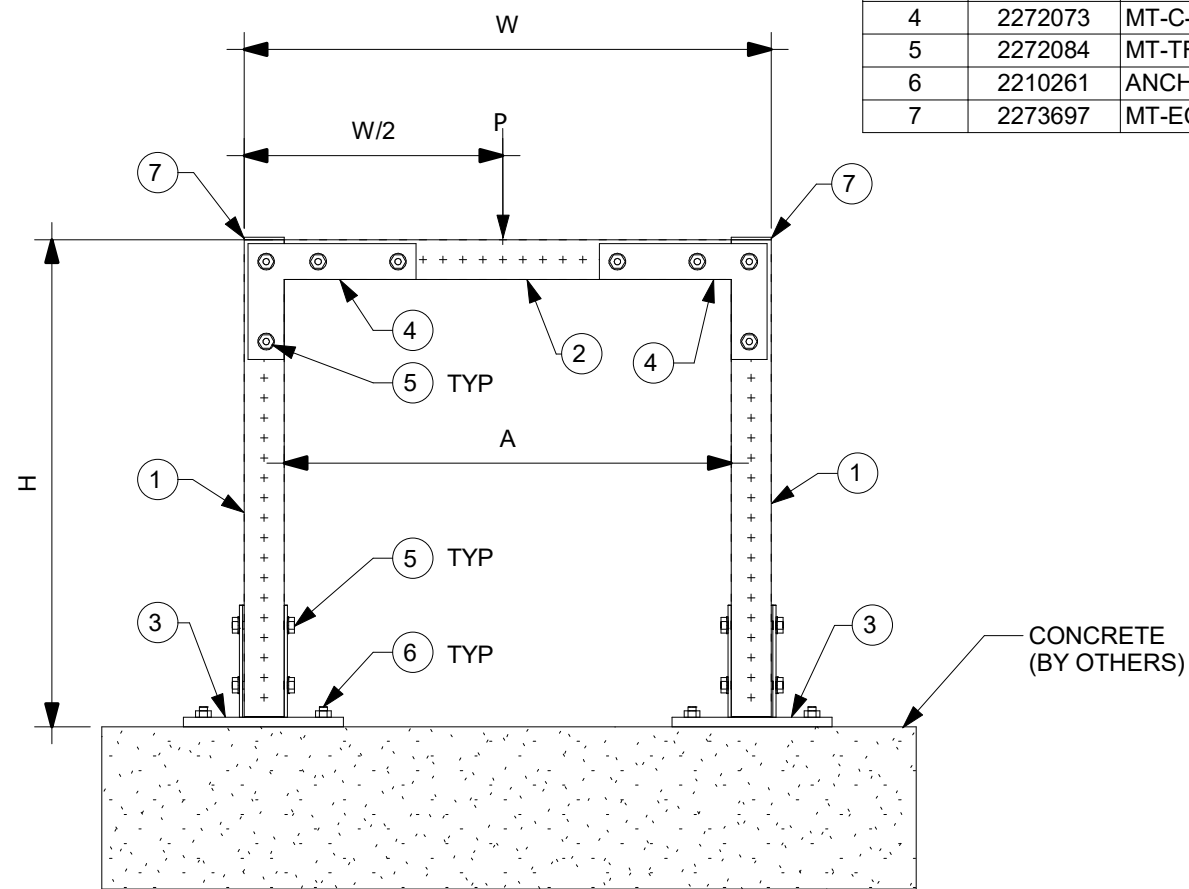

2 ELEVATION
N.T.S.

NOTE(S):

A. THE TYPICAL SUPPORT IS LOAD RATED AND DIMENSIONALLY LIMITED BASED ON DESIGN METHODOLOGY AND GENERIC NON-PROJECT SPECIFIC ASSUMPTIONS SET FORTH IN PROFIS MODULAR SUPPORTS ENGINEERING SOFTWARE VERSION 1.3. THE ENGINEER OF RECORD SHALL EVALUATE THIS TYPICAL SUPPORT TO DETERMINE ITS SUITABILITY FOR THE ACTUAL PROJECT SPECIFIC DESIGN CRITERIA AND REQUIREMENTS.

B. THE EVALUATION OF EXISTING STRUCTURE IS OUTSIDE OF THE TYPICAL DESIGN SCOPE AND SHALL BE PERFORMED BY THE ENGINEER OF RECORD.

C. TYPICAL SUPPORT DESIGN IS BASED ON INTERNATIONAL BUILDING CODE (IBC) 2018. SEE TABLE-A FOR ALLOWABLE STRENGTH DESIGN LOADS (STATIC U.N.O.); GOVERNING LATERAL LOADS NOTED IN THE ALLOWABLE LOAD TABLE IS MAXIMUM OF 30% OF DEAD LOAD.

D. ALL LOADS ASSUMED TO ACT ON THE SUPPORT, NO ECCENTRICITY CONSIDERED

E. MAXIMUM ALLOWABLE LOADS NOTED IN TABLE-A ARE BASED ON THE GOVERNING COMBINATION OF VERTICAL LOAD WITH TRANSVERSE LOAD OR VERTICAL LOAD WITH LONGITUDINAL LOAD. A SEPARATE ANALYSIS MUST BE PERFORMED WHEN TRANSVERSE AND LONGITUDINAL LOAD OCCURS SIMULTANEOUSLY.

F. REFER TO HILTI INSTRUCTION FOR USE SHEET FOR REQUIRED INSTALLATION INFORMATION. THREAD FORMING BOLT MAY BE INSTALLED USING A TORQUE WRENCH OR SI-AT-A22 PER INSTRUCTION FOR USE.

G. SEE BOM FOR KWIK BOLT-TZ2 ANCHOR BOLT. FOR 1/2" DIA. HILTI KWIK BOLT-TZ2 USE MIN. 3-1/4" EFFECTIVE EMBEDMENT. FOR 5/8" DIA. KWIK BOLT-TZ2 USE 3-1/4" MIN. EFFECTIVE EMBEDMENT. INSTALL ANCHOR PER ESR-4266 AND HILTI'S INSTRUCTIONS FOR USE AND RECOMMENDATIONS. MIN. CONCRETE COMPRESSIVE STRENGTH F'C=3000 PSI, MIN. CONCRETE EDGE DISTANCE = 6", AND MIN. CONCRETE THICKNESS = 6".

H. CONCRETE ANCHORS NOTED IN THE BILL OF MATERIAL ARE DESIGNED ONLY FOR WIND LATERAL LOADING. ENGINEER OF RECORD TO VERIFY ADEQUACY OF ANCHOR WHEN TYPICAL IS BEING USED FOR SEISMIC LATERAL LOADING.

	24	36	48
Max H, in	24	36	48
Max W, in	24	36	48
Max A, in	20-1/8	32-1/8	44-1/8
Vertical (P)	1400	950	620
Transverse	420	285	186
Longitudinal	420	285	186

ALLOWABLE
LOADS, lbs

All loading and design criteria supplied by customer is assumed accurate. Only the stated Design Assumptions were considered, and must be verified by the responsible Engineer of Record (EOR). The basis of Hilti component and connection design is the published data in the current Hilti Technical Guide, including material and cross-section properties, allowable load values, factors of safety, methods of calculation, and limiting factors. The EOR must verify suitability for any specific application, and the capacity of the supportive structure to receive the shown configuration and associated reaction loads. Modification to components and/or design may alter performance and must be evaluated by the EOR.

REVISION HISTORY

NO.	DESCRIPTION:	DATE:
B	ISSUE FOR REVIEW	03/03/2021
C	ISSUE FOR BU USE	07/06/2021
D	ANCHOR NOTE AND BOM MODIFICATION FOR ANCHOR	03/22/2022

PROJECT NAME:

GOAL POST MT70 C 001

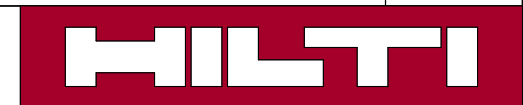

PROJECT DESCRIPTION:

GOAL POST MT70 C 001

DRAWN:	CHECKED:	DESIGNED:	REVIEWED:
GAB	IDP	JDR	BVD
PAPER SIZE:	PROJECT NUMBER:		
ANSI B	PROJECT	JOB	SHEET
	- GP7C1 -		1

MARK	ITEM NO.	DESCRIPTION	QTY.
1	2268365	MT-70 OC	2
2	2268365	MT-70 OC	1
3	2272101	MT-B-GS O4U OC	2
4	2272073	MT-C-GSP L OC	4
5	2272084	MT-TFB OC	28
6	2194341	X-BT-MR W10/15 SN 8	8
7	2273697	MT-EC-70	2

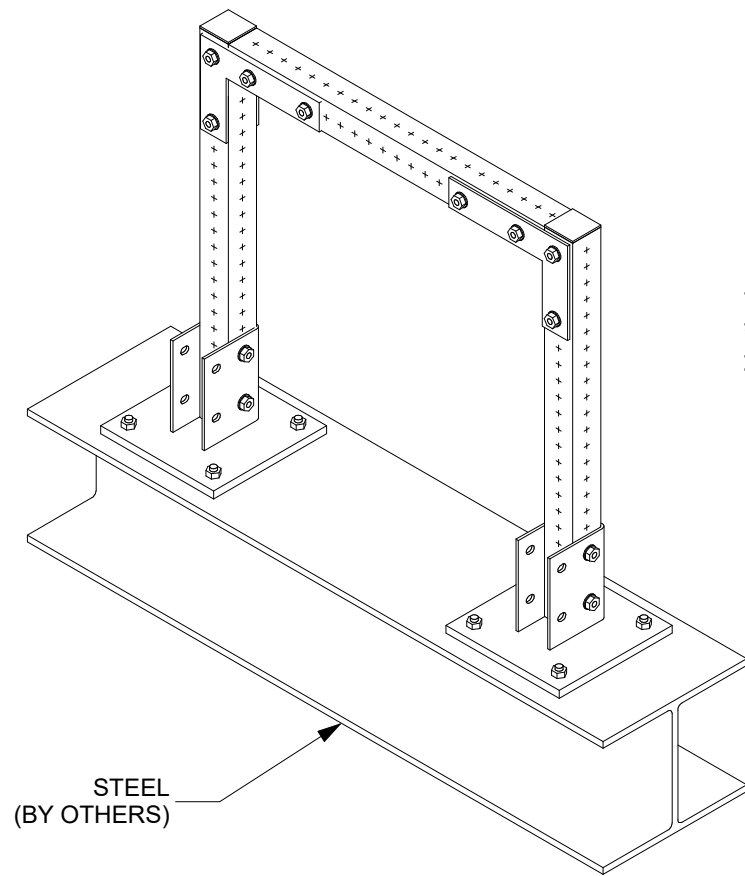

1 ISOMETRIC
N.T.S.

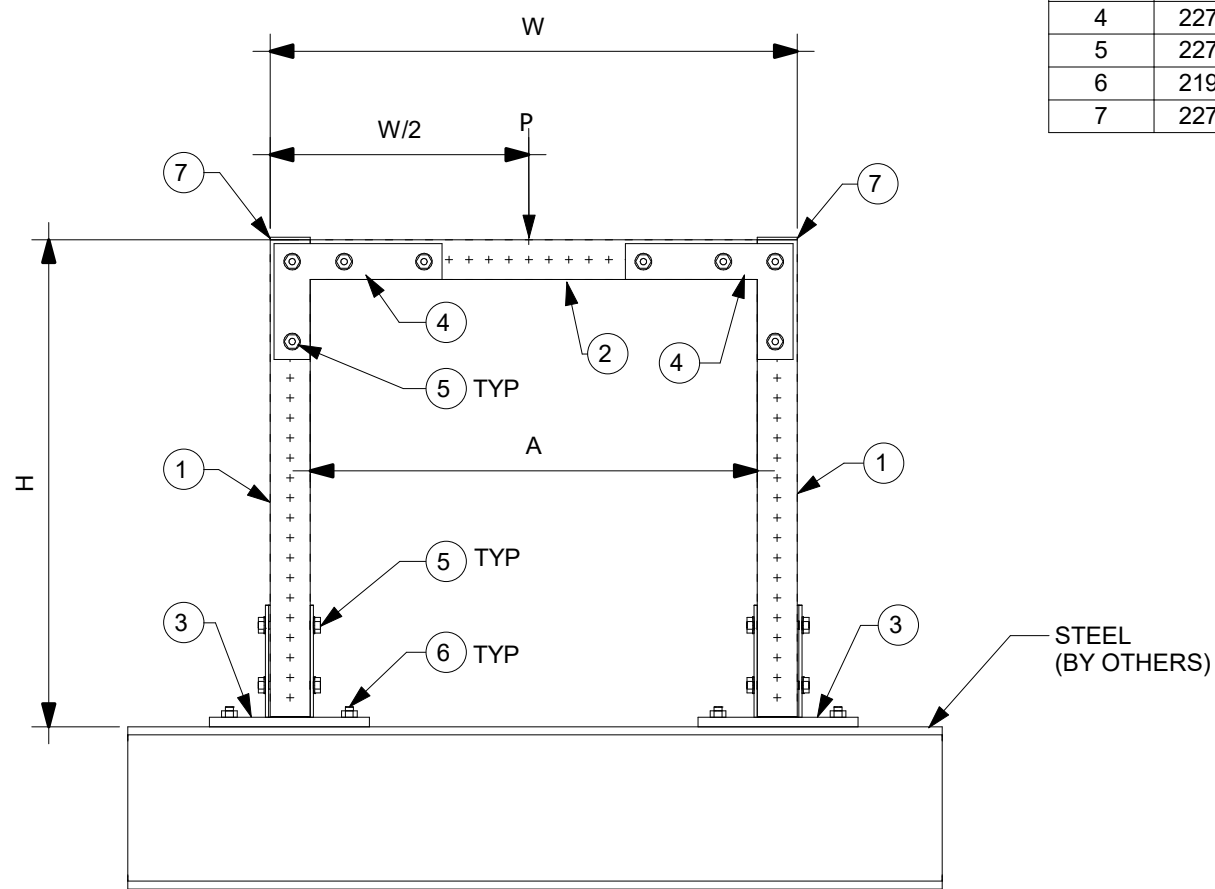

2 ELEVATION
N.T.S.

NOTE(S):

A. THE TYPICAL SUPPORT IS LOAD RATED AND DIMENSIONALLY LIMITED BASED ON DESIGN METHODOLOGY AND GENERIC NON-PROJECT SPECIFIC ASSUMPTIONS SET FORTH IN PROFIS MODULAR SUPPORTS ENGINEERING SOFTWARE VERSION 1.3. THE ENGINEER OF RECORD SHALL EVALUATE THIS TYPICAL SUPPORT TO DETERMINE ITS SUITABILITY FOR THE ACTUAL PROJECT SPECIFIC DESIGN CRITERIA AND REQUIREMENTS.

B. THE EVALUATION OF EXISTING STRUCTURE IS OUTSIDE OF THE TYPICAL DESIGN SCOPE AND SHALL BE PERFORMED BY THE ENGINEER OF RECORD.

C. TYPICAL SUPPORT DESIGN IS BASED ON INTERNATIONAL BUILDING CODE (IBC) 2018. SEE TABLE-A FOR ALLOWABLE STRENGTH DESIGN LOADS (STATIC U.N.O.); GOVERNING LATERAL LOADS NOTED IN THE ALLOWABLE LOAD TABLE IS MAXIMUM OF 30% OF DEAD LOAD.

D. ALL LOADS ASSUMED TO ACT ON THE SUPPORT, NO ECCENTRICITY CONSIDERED.

E. MAXIMUM ALLOWABLE LOADS NOTED IN TABLE-A ARE BASED ON THE GOVERNING COMBINATION OF VERTICAL LOAD WITH TRANSVERSE LOAD OR VERTICAL LOAD WITH LONGITUDINAL LOAD. A SEPARATE ANALYSIS MUST BE PERFORMED WHEN TRANSVERSE AND LONGITUDINAL LOAD OCCURS SIMULTANEOUSLY.

F. REFER TO HILTI INSTRUCTION FOR USE SHEET FOR REQUIRED INSTALLATION INFORMATION. THREAD FORMING BOLT MAY BE INSTALLED USING A TORQUE WRENCH OR SI-AT-A22 PER INSTRUCTION FOR USE.

G. X-BT REQUIREMENT: MIN. STEEL BASE MATERIAL THICKNESS SHALL BE 5/16". MIN EDGE DISTANCE SHALL BE 3/8". MIN YIELD STRENGTH OF STEEL SHALL BE FY=36KSI.

H. MINIMUM 8" FLANGE WIDTH REQUIRED.

	24	36	48
Max H, in	24	36	48
Max W, in	24	36	48
Max A, in	20-1/8	32-1/8	44-1/8
Vertical (P)	1400	950	620
Transverse	420	285	186
Longitudinal	420	285	186

ALLOWABLE
LOADS, lbs

All loading and design criteria supplied by customer is assumed accurate. Only the stated Design Assumptions were considered, and must be verified by the responsible Engineer of Record (EOR). The basis of Hilti component and connection design is the published data in the current Hilti Technical Guide, including material and cross-section properties, allowable load values, factors of safety, methods of calculation, and limiting factors. The EOR must verify suitability for any specific application, and the capacity of the supportive structure to receive the shown configuration and associated reaction loads. Modification to components and/or design may alter performance and must be evaluated by the EOR.

REVISION HISTORY

NO.	DESCRIPTION:	DATE:
A	ISSUE FOR REVIEW	12/14/2020
B	ISSUE FOR REVIEW - NOTE MODIFICATIONS AND DIM CALLOUTS	03/03/2021
C	ISSUE FOR REVIEW - NOTE MODIFICATIONS AND DIM CALLOUTS	05/28/2021

PROJECT NAME:

GOAL POST MT70 S 001



PROJECT DESCRIPTION:

GOAL POST MT70 S 001

DRAWN:	CHECKED:	DESIGNED:	REVIEWED:
GAB	IDP	JDR	BVD
PAPER SIZE:	PROJECT NUMBER:		
ANSI B	PROJECT	JOB	SHEET
	- GP7S1 -		1

MARK	ITEM NO.	DESCRIPTION	QTY.
1	2268369	MT-90 OC	2
2	2268369	MT-90 OC	1
3	2272103	MT-B-GL-O4 OC	2
4	2272075	MT-C-GLP T OC	4
5	2272084	MT-TFB OC	80
6	2210278	ANCHOR KB-TZ2 5/8" X 4-3/4" SS304	8
7	2273699	MT-EC-90	2

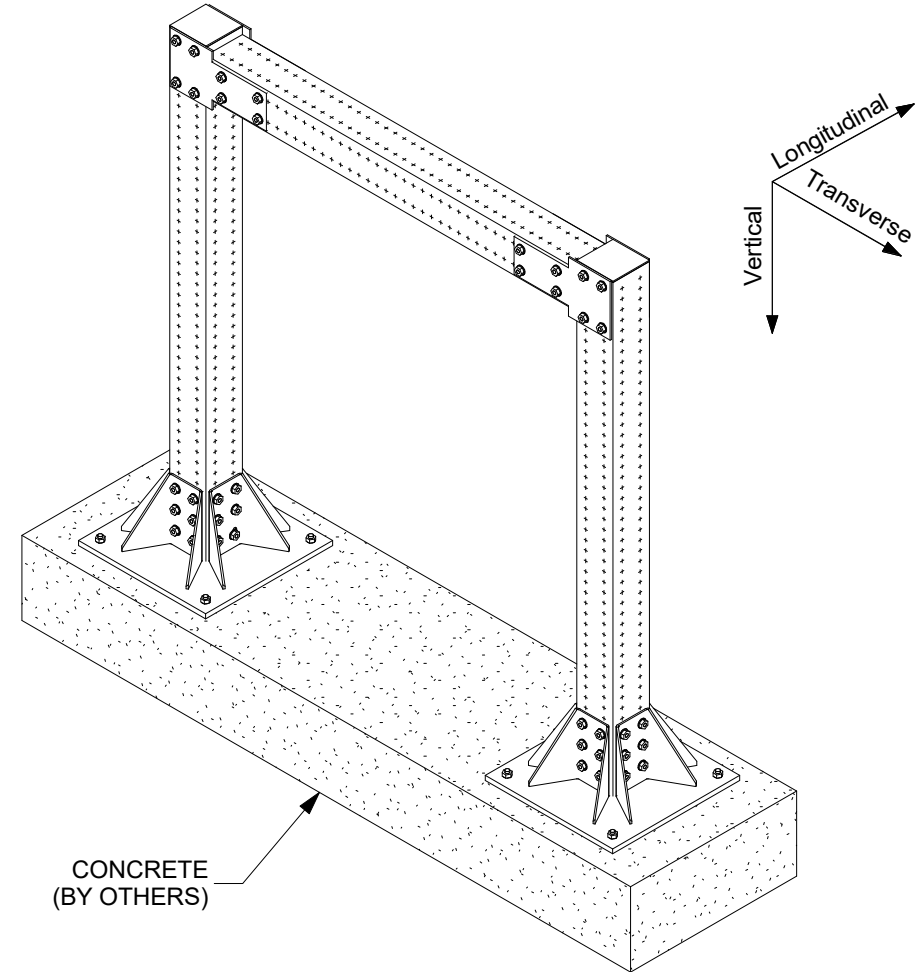

1 ISOMETRIC
N.T.S.

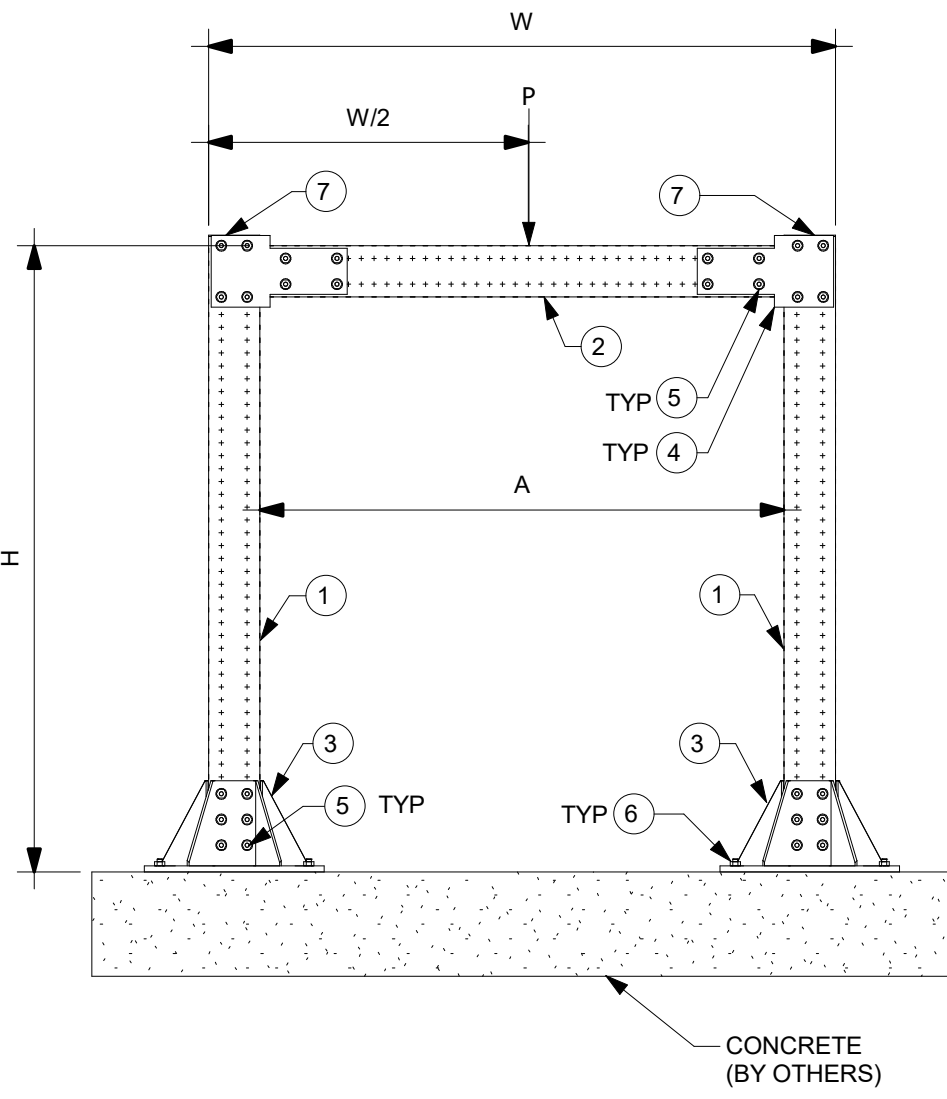

2 ELEVATION
N.T.S.

NOTE(S):

A. THE TYPICAL SUPPORT IS LOAD RATED AND DIMENSIONALLY LIMITED BASED ON DESIGN METHODOLOGY AND GENERIC NON-PROJECT SPECIFIC ASSUMPTIONS SET FORTH IN PROFIS MODULAR SUPPORTS ENGINEERING SOFTWARE VERSION 1.3. THE ENGINEER OF RECORD SHALL EVALUATE THIS TYPICAL SUPPORT TO DETERMINE ITS SUITABILITY FOR THE ACTUAL PROJECT SPECIFIC DESIGN CRITERIA AND REQUIREMENTS.

B. THE EVALUATION OF EXISTING STRUCTURE IS OUTSIDE OF THE TYPICAL DESIGN SCOPE AND SHALL BE PERFORMED BY THE ENGINEER OF RECORD.

C. TYPICAL SUPPORT DESIGN IS BASED ON INTERNATIONAL BUILDING CODE (IBC) 2018. SEE TABLE-A FOR ALLOWABLE STRENGTH DESIGN LOADS (STATIC U.N.O.); GOVERNING LATERAL LOADS NOTED IN THE ALLOWABLE LOAD TABLE IS MAXIMUM OF 30% OF DEAD LOAD.

D. ALL LOADS ASSUMED TO ACT ON THE SUPPORT, NO ECCENTRICITY CONSIDERED

E. MAXIMUM ALLOWABLE LOADS NOTED IN TABLE-A ARE BASED ON THE GOVERNING COMBINATION OF VERTICAL LOAD WITH TRANSVERSE LOAD OR VERTICAL LOAD WITH LONGITUDINAL LOAD. A SEPARATE ANALYSIS MUST BE PERFORMED WHEN TRANSVERSE AND LONGITUDINAL LOAD OCCURS SIMULTANEOUSLY.

F. REFER TO HILTI INSTRUCTION FOR USE SHEET FOR REQUIRED INSTALLATION INFORMATION. THREAD FORMING BOLT MAY BE INSTALLED USING A TORQUE WRENCH OR SI-AT-A22 PER INSTRUCTION FOR USE.

G. SEE BOM FOR KWIK BOLT-TZ2 ANCHOR BOLT. FOR 1/2" DIA. HILTI KWIK BOLT-TZ2 USE MIN. 3-1/4" EFFECTIVE EMBEDMENT. FOR 5/8" DIA. KWIK BOLT-TZ2 USE 3-1/4" MIN. EFFECTIVE EMBEDMENT. INSTALL ANCHOR PER ESR-4266 AND HILTI'S INSTRUCTIONS FOR USE AND RECOMMENDATIONS. MIN. CONCRETE COMPRESSIVE STRENGTH $f'c=3000$ PSI, MIN. CONCRETE EDGE DISTANCE = 6", AND MIN. CONCRETE THICKNESS = 6".

H. CONCRETE ANCHORS NOTED IN THE BILL OF MATERIAL ARE DESIGNED ONLY FOR WIND LATERAL LOADING. ENGINEER OF RECORD TO VERIFY ADEQUACY OF ANCHOR WHEN TYPICAL IS BEING USED FOR SEISMIC LATERAL LOADING.

	36	48	60
Max H, in	36	48	60
Max W, in	36	48	60
Max A, in	28-1/8	40-1/8	52-1/8
Vertical (P)	4400	3400	2600
Transverse	1320	1020	780
Longitudinal	1320	1020	780

ALLOWABLE LOADS, lbs

REVISION HISTORY		
NO.	DESCRIPTION:	DATE:
B	ISSUE FOR REVIEW - UPDATED DIMENSIONS	03/03/2021
C	ISSUE FOR BU USE	07/06/2021
D	ANCHOR NOTE AND BOM MODIFICATION FOR ANCHOR	03/22/2022

PROJECT NAME: **GOAL POST MT90 C 001**

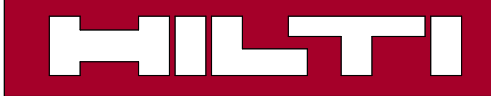

DRAWN: GAB CHECKED: IDP DESIGNED: JDR REVIEWED: BVD

PROJECT DESCRIPTION: **GOAL POST MT90 C 001**

PAPER SIZE: ANSI B PROJECT: GP9C1 JOB: SHEET: 1

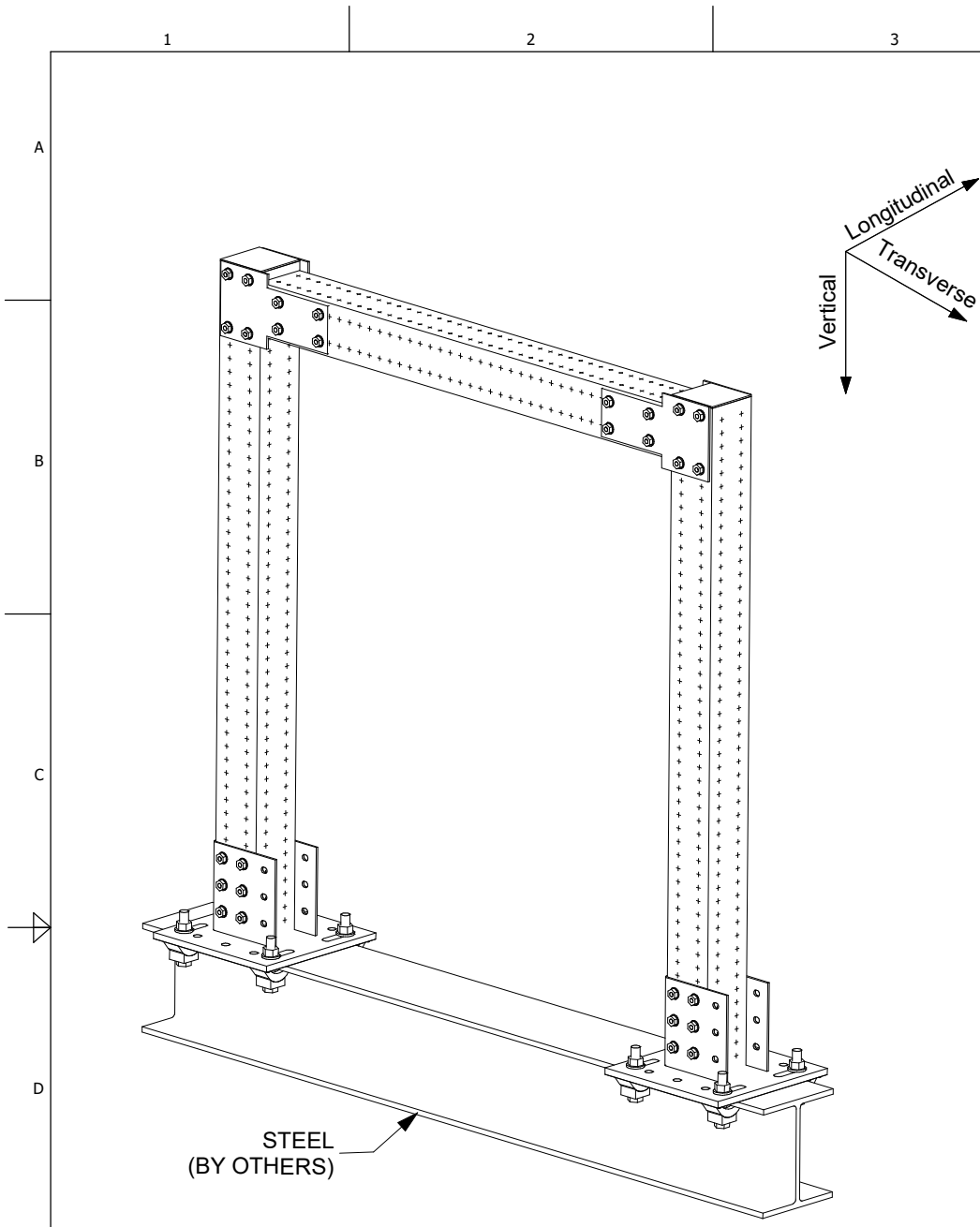

1 ISOMETRIC
N.T.S.

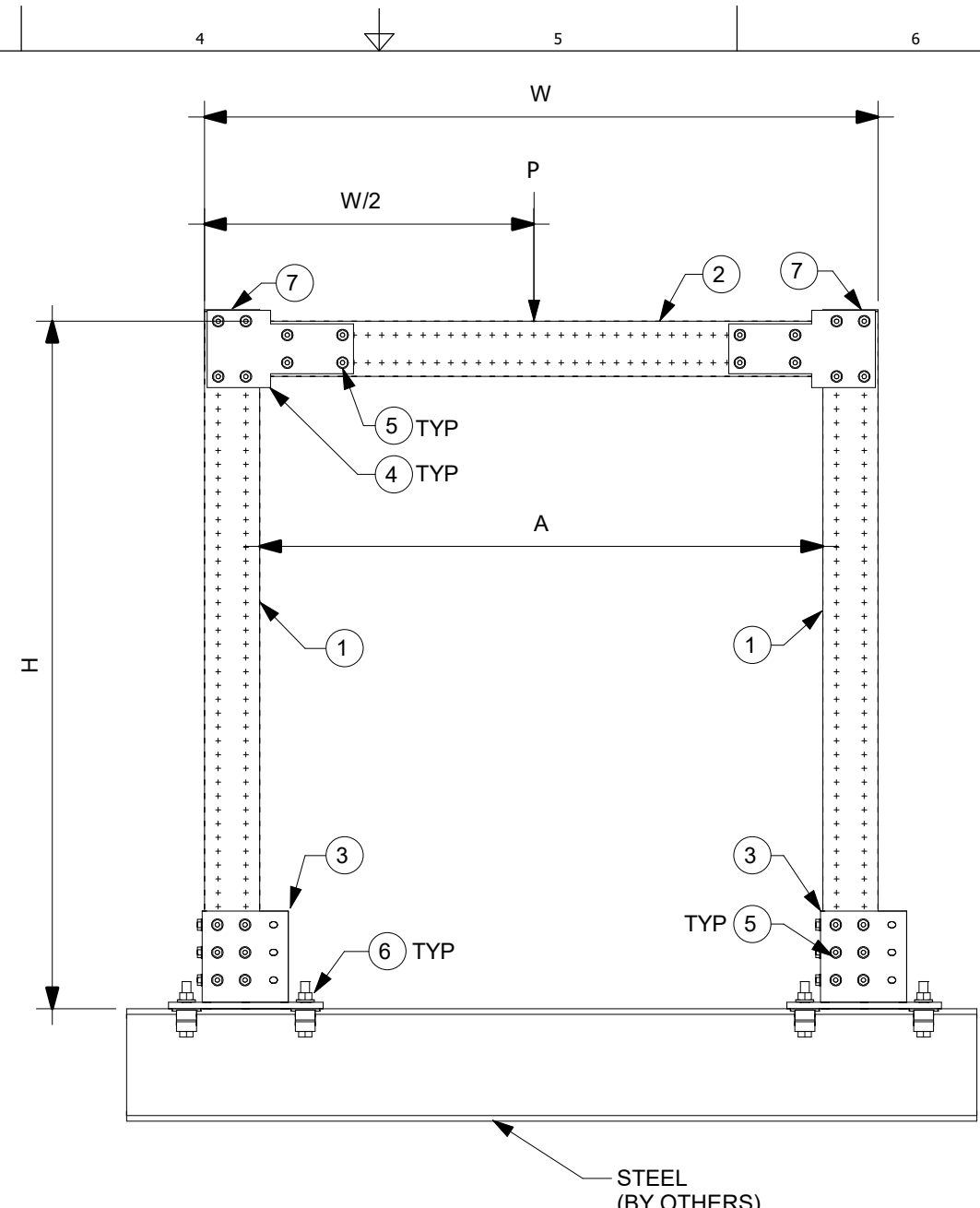

2 ELEVATION
N.T.S.

MARK	ITEM NO.	DESCRIPTION	QTY.
1	2268369	MT-90 OC	2
2	2268369	MT-90 OC	1
3	VARIES	MT-B-GXL S+ OC (SEE TABLE)	2
4	2272075	MT-C-GLP T OC	4
5	2272084	MT-TFB OC	68
6	387398	MI-SGC M16	8
7	2273699	MT-EC-90	2

MT-B-GXL S+ OC		
+	'B' Width	Item No.
1	2.9 to 6.5	2272106
2	6.5 to 9.2	2272107
3	9.2 to 11.8	2272108

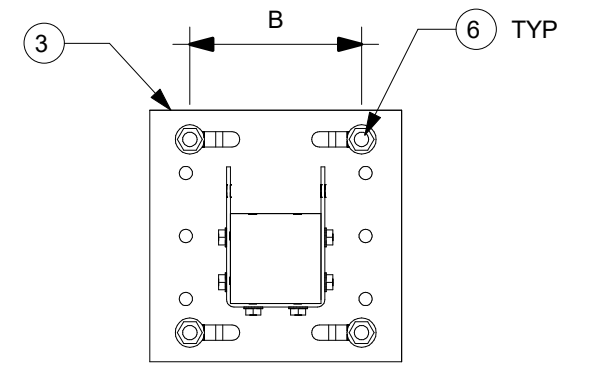

3 BASEPLATE DETAIL
N.T.S.

NOTE(S):

A. THE TYPICAL SUPPORT IS LOAD RATED AND DIMENSIONALLY LIMITED BASED ON DESIGN METHODOLOGY AND GENERIC NON-PROJECT SPECIFIC ASSUMPTIONS SET FORTH IN PROFIS MODULAR SUPPORTS ENGINEERING SOFTWARE VERSION 1.3. THE ENGINEER OF RECORD SHALL EVALUATE THIS TYPICAL SUPPORT TO DETERMINE ITS SUITABILITY FOR THE ACTUAL PROJECT SPECIFIC DESIGN CRITERIA AND REQUIREMENTS.

B. THE EVALUATION OF EXISTING STRUCTURE IS OUTSIDE OF THE TYPICAL DESIGN SCOPE AND SHALL BE PERFORMED BY THE ENGINEER OF RECORD.

C. TYPICAL SUPPORT DESIGN IS BASED ON INTERNATIONAL BUILDING CODE (IBC) 2018. SEE TABLE-A FOR ALLOWABLE STRENGTH DESIGN LOADS (STATIC U.N.O.); GOVERNING LATERAL LOADS NOTED IN THE ALLOWABLE LOAD TABLE IS MAXIMUM OF 30% OF DEAD LOAD.

D. ALL LOADS ASSUMED TO ACT ON THE SUPPORT, NO ECCENTRICITY CONSIDERED.

E. MAXIMUM ALLOWABLE LOADS NOTED IN TABLE-A ARE BASED ON THE GOVERNING COMBINATION OF VERTICAL LOAD WITH TRANSVERSE LOAD OR VERTICAL LOAD WITH LONGITUDINAL LOAD. A SEPARATE ANALYSIS MUST BE PERFORMED WHEN TRANSVERSE AND LONGITUDINAL LOAD OCCURS SIMULTANEOUSLY.

F. REFER TO HILTI INSTRUCTION FOR USE SHEET FOR REQUIRED INSTALLATION INFORMATION. THREAD FORMING BOLT MAY BE INSTALLED USING A TORQUE WRENCH OR SI-AT-A22 PER INSTRUCTION FOR USE.

TABLE A				
Max H, in	36	48	60	
Max W, in	36	48	60	
Max A, in	28-1/8	40-1/8	52-1/8	
Vertical (P)	4400	3400	2600	
Transverse	1320	1020	780	
Longitudinal	1320	1020	780	

ALLOWABLE LOADS, lbs

REVISION HISTORY	
NO:	DESCRIPTION:
A	ISSUE FOR REVIEW
B	NOTE MODIFICATIONS
C	ISSUE FOR REVIEW - NOTE MODIFICATIONS AND DIM CALLOUTS

DATE: 12/18/2020
01/29/2021
05/28/2021

PROJECT NAME: GOAL POST MT90 S 001

PROJECT DESCRIPTION: GOAL POST MT90 S 001

DRAWN: GAB
CHECKED: IDP
DESIGNED: JDR
REVIEWED: BVD

PAPER SIZE: ANSI B

PROJECT NUMBER: GP9S1 - 1

MARK	ITEM NO.	DESCRIPTION	QTY.
1	2268365	MT-70 OC	2
2	2268365	MT-70 OC	2
3	2272101	MT-B-GS O4U OC	2
4	2272073	MT-C-GSP L OC	8
5	2272084	MT-TFB OC	44
6	2210261	ANCHOR KB-TZ2 1/2" x 4-1/2" SS304	8
7	2273697	MT-EC-70	2

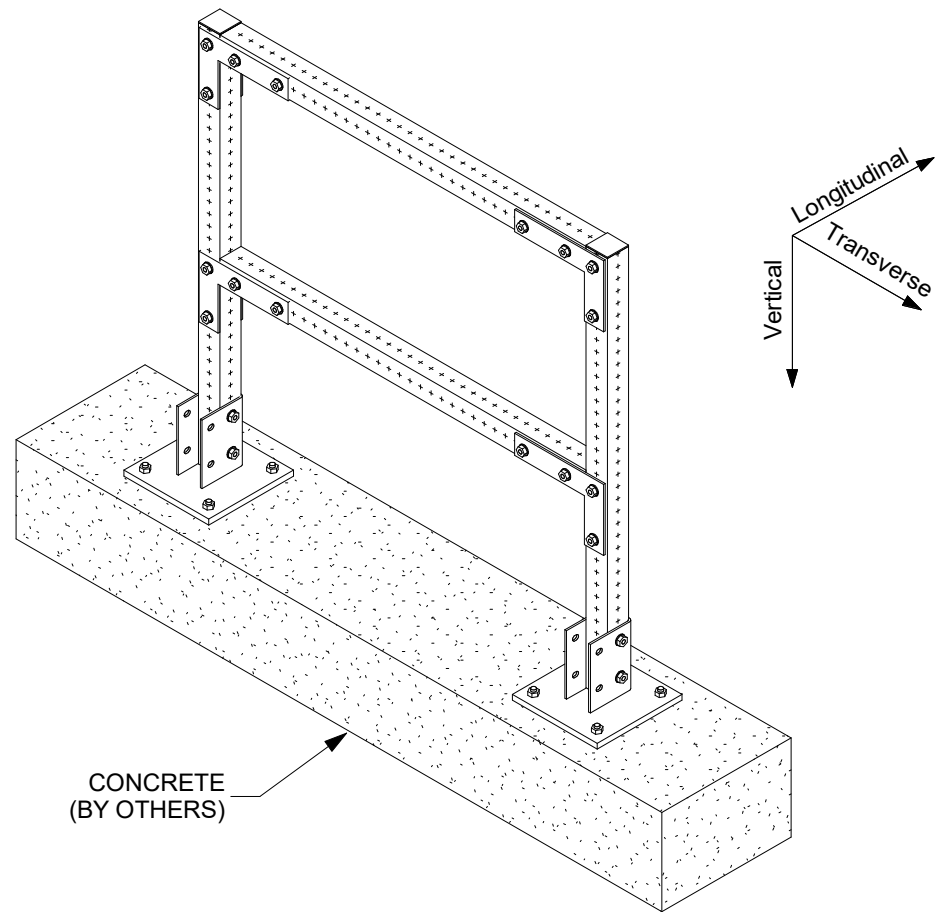

1 ISOMETRIC
N.T.S.

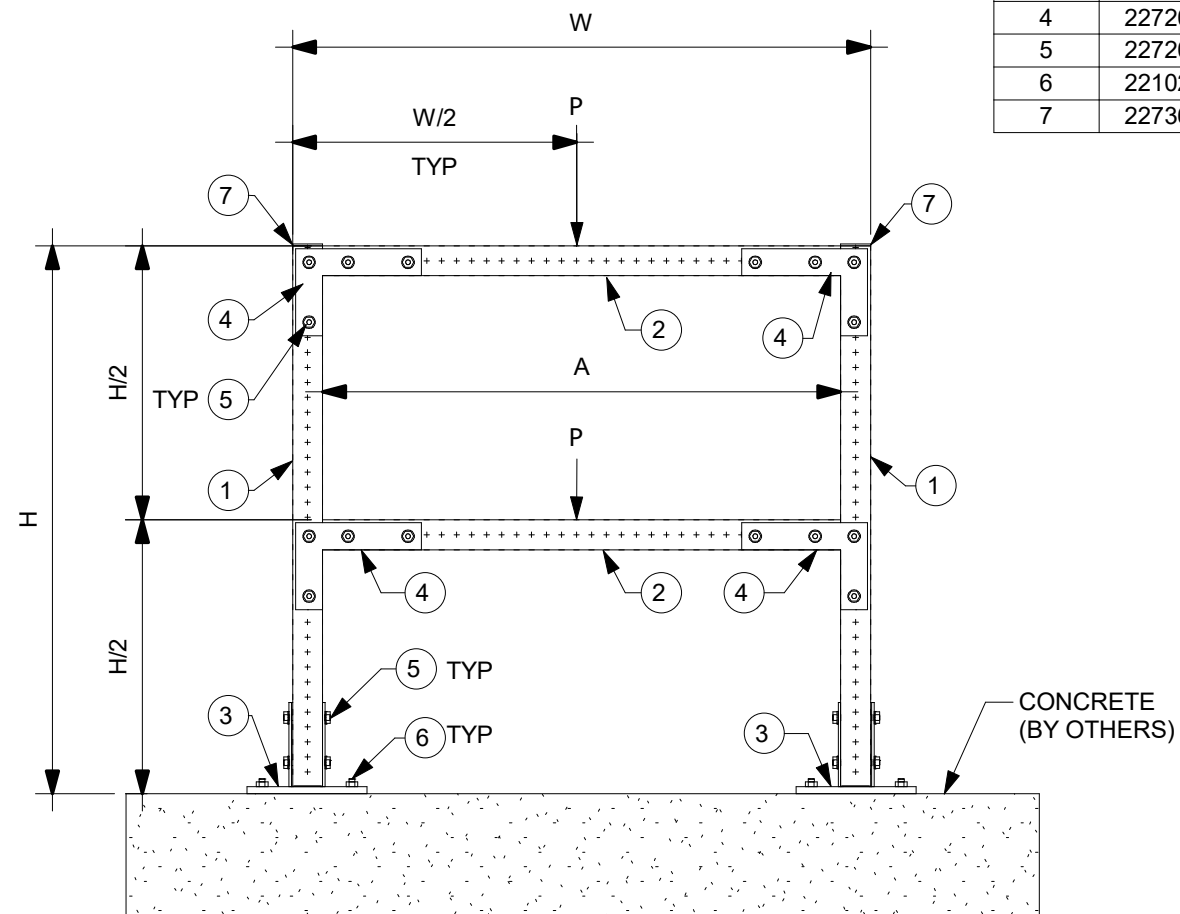

2 ELEVATION
N.T.S.

NOTE(S):

A. THE TYPICAL SUPPORT IS LOAD RATED AND DIMENSIONALLY LIMITED BASED ON DESIGN METHODOLOGY AND GENERIC NON-PROJECT SPECIFIC ASSUMPTIONS SET FORTH IN PROFIS MODULAR SUPPORTS ENGINEERING SOFTWARE VERSION 1.3. THE ENGINEER OF RECORD SHALL EVALUATE THIS TYPICAL SUPPORT TO DETERMINE ITS SUITABILITY FOR THE ACTUAL PROJECT SPECIFIC DESIGN CRITERIA AND REQUIREMENTS.

B. THE EVALUATION OF EXISTING STRUCTURE IS OUTSIDE OF THE TYPICAL DESIGN SCOPE AND SHALL BE PERFORMED BY THE ENGINEER OF RECORD.

C. TYPICAL SUPPORT DESIGN IS BASED ON INTERNATIONAL BUILDING CODE (IBC) 2018. SEE TABLE-A FOR ALLOWABLE STRENGTH DESIGN LOADS (STATIC U.N.O.); GOVERNING LATERAL LOADS NOTED IN THE ALLOWABLE LOAD TABLE IS MAXIMUM OF 30% OF DEAD LOAD.

D. ALL LOADS ASSUMED TO ACT ON THE SUPPORT, NO ECCENTRICITY CONSIDERED

E. MAXIMUM ALLOWABLE LOADS NOTED IN TABLE-A ARE BASED ON THE GOVERNING COMBINATION OF VERTICAL LOAD WITH TRANSVERSE LOAD OR VERTICAL LOAD WITH LONGITUDINAL LOAD. A SEPARATE ANALYSIS MUST BE PERFORMED WHEN TRANSVERSE AND LONGITUDINAL LOAD OCCURS SIMULTANEOUSLY.

F. REFER TO HILTI INSTRUCTION FOR USE SHEET FOR REQUIRED INSTALLATION INFORMATION. THREAD FORMING BOLT MAY BE INSTALLED USING A TORQUE WRENCH OR SI-AT-A22 PER INSTRUCTION FOR USE.

G. SEE BOM FOR KWIK BOLT-TZ2 ANCHOR BOLT. FOR 1/2" DIA. HILTI KWIK BOLT-TZ2 USE MIN. 3-1/4" EFFECTIVE EMBEDMENT. FOR 5/8" DIA. KWIK BOLT-TZ2 USE 3-1/4" MIN. EFFECTIVE EMBEDMENT. INSTALL ANCHOR PER ESR-4266 AND HILTI'S INSTRUCTIONS FOR USE AND RECOMMENDATIONS. MIN. CONCRETE COMPRESSIVE STRENGTH F'C=3000 PSI, MIN. CONCRETE EDGE DISTANCE = 6", AND MIN. CONCRETE THICKNESS = 6".

H. CONCRETE ANCHORS NOTED IN THE BILL OF MATERIAL ARE DESIGNED ONLY FOR WIND LATERAL LOADING. ENGINEER OF RECORD TO VERIFY ADEQUACY OF ANCHOR WHEN TYPICAL IS BEING USED FOR SEISMIC LATERAL LOADING.

	24	36	48
Max H, in	24	36	48
Max W, in	24	36	48
Max A, in	20-1/8	32-1/8	44-1/8
Vertical (P)	1400	850	475
Transverse	420	255	143
Longitudinal	420	255	143

ALLOWABLE
LOADS, lbs

All loading and design criteria supplied by customer is assumed accurate. Only the stated Design Assumptions were considered, and must be verified by the responsible Engineer of Record (EOR). The basis of Hilti component and connection design is the published data in the current Hilti Technical Guide, including material and cross-section properties, allowable load values, factors of safety, methods of calculation, and limiting factors. The EOR must verify suitability for any specific application, and the capacity of the supportive structure to receive the shown configuration and associated reaction loads. Modification to components and/or design may alter performance and must be evaluated by the EOR.

REVISION HISTORY

NO.	DESCRIPTION:	DATE:
B	ISSUE FOR REVIEW - UPDATED DIMENSIONS	03/03/2021
C	ISSUE FOR BU USE	07/06/2021
D	ANCHOR NOTE AND BOM MODIFICATION FOR ANCHOR	03/22/2022

PROJECT NAME:

GOAL POST MT70 C 002

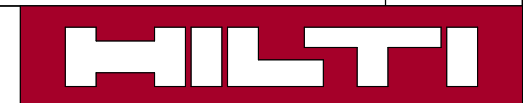

PROJECT DESCRIPTION:

GOAL POST MT70 C 002

DRAWN:	CHECKED:	DESIGNED:	REVIEWED:
GAB	IDP	JDR	BVD
PAPER SIZE:	PROJECT NUMBER:		
ANSI B	PROJECT	JOB	SHEET
	- GP7C2 -		1

MARK	ITEM NO.	DESCRIPTION	QTY.
1	2268369	MT-90 OC	2
2	2268369	MT-90 OC	2
3	2272103	MT-B-GL-O4 OC	2
4	2272075	MT-C-GLP T OC	8
5	2272084	MT-TFB OC	112
6	2210278	ANCHOR KB-TZ2 5/8" X 4-3/4" SS304	8
7	2273699	MT-EC-90	2

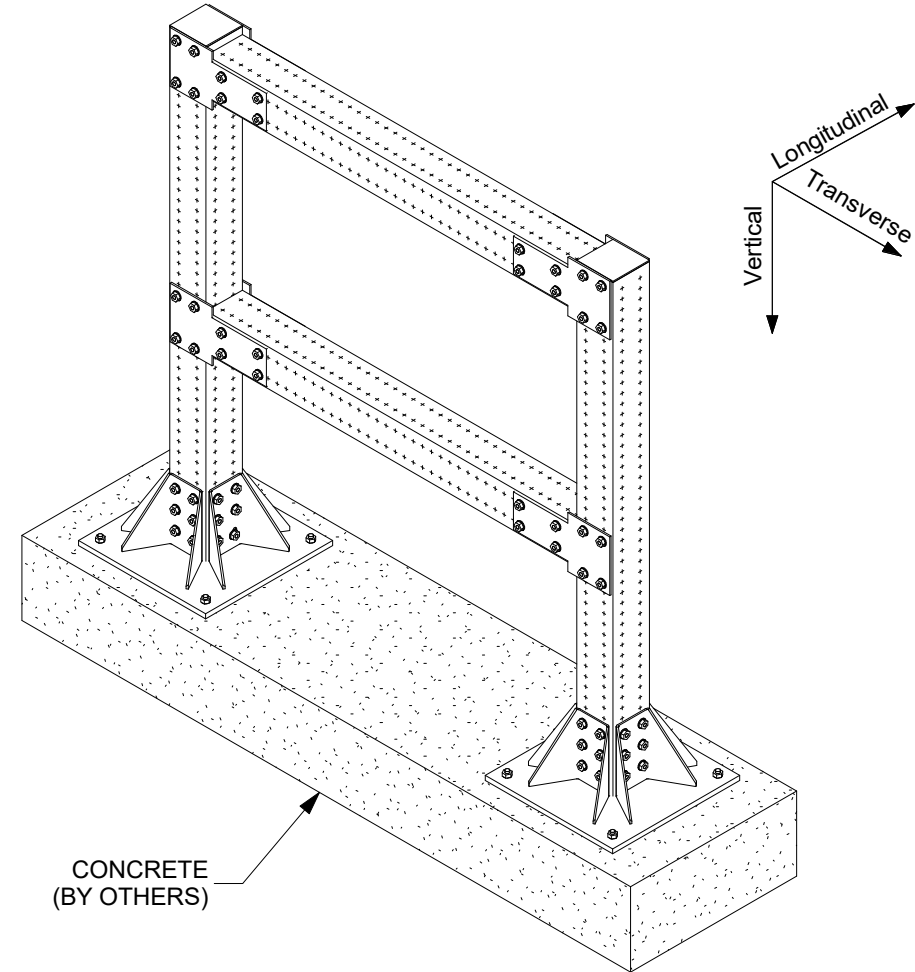

1 ISOMETRIC
N.T.S.

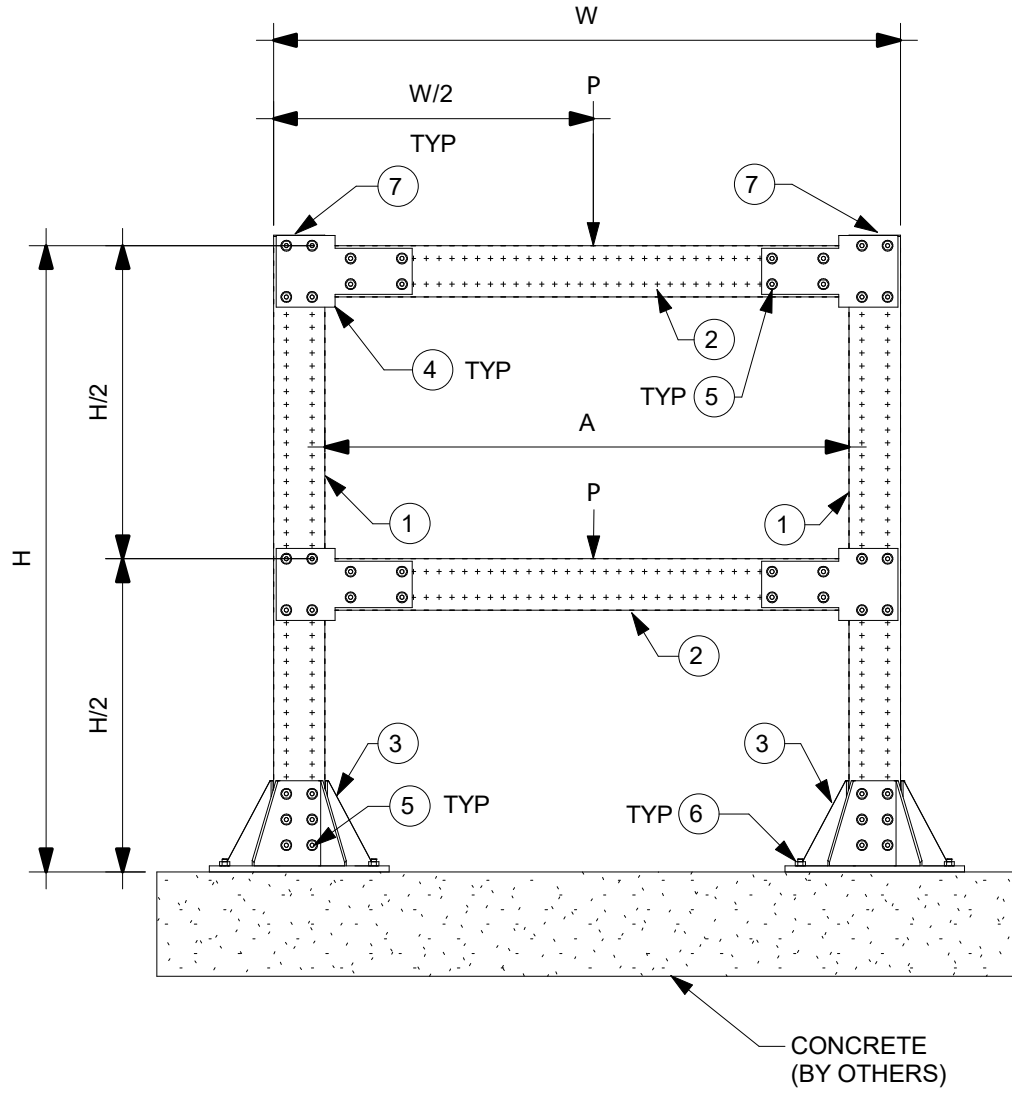

2 ELEVATION
N.T.S.

NOTE(S):

A. THE TYPICAL SUPPORT IS LOAD RATED AND DIMENSIONALLY LIMITED BASED ON DESIGN METHODOLOGY AND GENERIC NON-PROJECT SPECIFIC ASSUMPTIONS SET FORTH IN PROFIS MODULAR SUPPORTS ENGINEERING SOFTWARE VERSION 1.3. THE ENGINEER OF RECORD SHALL EVALUATE THIS TYPICAL SUPPORT TO DETERMINE ITS SUITABILITY FOR THE ACTUAL PROJECT SPECIFIC DESIGN CRITERIA AND REQUIREMENTS.

B. THE EVALUATION OF EXISTING STRUCTURE IS OUTSIDE OF THE TYPICAL DESIGN SCOPE AND SHALL BE PERFORMED BY THE ENGINEER OF RECORD.

C. TYPICAL SUPPORT DESIGN IS BASED ON INTERNATIONAL BUILDING CODE (IBC) 2018. SEE TABLE-A FOR ALLOWABLE STRENGTH DESIGN LOADS (STATIC U.N.O.); GOVERNING LATERAL LOADS NOTED IN THE ALLOWABLE LOAD TABLE IS MAXIMUM OF 30% OF DEAD LOAD.

D. ALL LOADS ASSUMED TO ACT ON THE SUPPORT, NO ECCENTRICITY CONSIDERED

E. MAXIMUM ALLOWABLE LOADS NOTED IN TABLE-A ARE BASED ON THE GOVERNING COMBINATION OF VERTICAL LOAD WITH TRANSVERSE LOAD OR VERTICAL LOAD WITH LONGITUDINAL LOAD. A SEPARATE ANALYSIS MUST BE PERFORMED WHEN TRANSVERSE AND LONGITUDINAL LOAD OCCURS SIMULTANEOUSLY.

F. REFER TO HILTI INSTRUCTION FOR USE SHEET FOR REQUIRED INSTALLATION INFORMATION. THREAD FORMING BOLT MAY BE INSTALLED USING A TORQUE WRENCH OR SI-AT-A22 PER INSTRUCTION FOR USE.

G. SEE BOM FOR KWIK BOLT-TZ2 ANCHOR BOLT. FOR 1/2" DIA. HILTI KWIK BOLT-TZ2 USE MIN. 3-1/4" EFFECTIVE EMBEDMENT. FOR 5/8" DIA. KWIK BOLT-TZ2 USE 3-1/4" MIN. EFFECTIVE EMBEDMENT. INSTALL ANCHOR PER ESR-4266 AND HILTI'S INSTRUCTIONS FOR USE AND RECOMMENDATIONS. MIN. CONCRETE COMPRESSIVE STRENGTH $f'c=3000$ PSI, MIN. CONCRETE EDGE DISTANCE = 6", AND MIN. CONCRETE THICKNESS = 6".

H. CONCRETE ANCHORS NOTED IN THE BILL OF MATERIAL ARE DESIGNED ONLY FOR WIND LATERAL LOADING. ENGINEER OF RECORD TO VERIFY ADEQUACY OF ANCHOR WHEN TYPICAL IS BEING USED FOR SEISMIC LATERAL LOADING.

	36	48	60
Max H, in	36	48	60
Max W, in	36	48	60
Max A, in	28-1/8	40-1/8	52-1/8
Vertical (P)	3400	2800	2500
Transverse	1020	840	750
Longitudinal	1020	840	750

ALLOWABLE LOADS, lbs

REVISION HISTORY			
NO.	DESCRIPTION:	DATE:	
B	NOTE MODIFICATIONS	01/29/2021	
C	ISSUE FOR BU USE	07/06/2021	
D	ANCHOR NOTE AND BOM MODIFICATION FOR ANCHOR	03/22/2022	

PROJECT NAME: **GOALPOST MT90 C 002**

PROJECT DESCRIPTION: **GOALPOST MT90 C 002**

HILTI

DRAWN:	CHECKED:	DESIGNED:	REVIEWED:
GAB	IDP	JDR	BVD
PAPER SIZE:	PROJECT NUMBER:		
ANSI B	PROJECT	JOB	SHEET
	- GP9C2 -		1

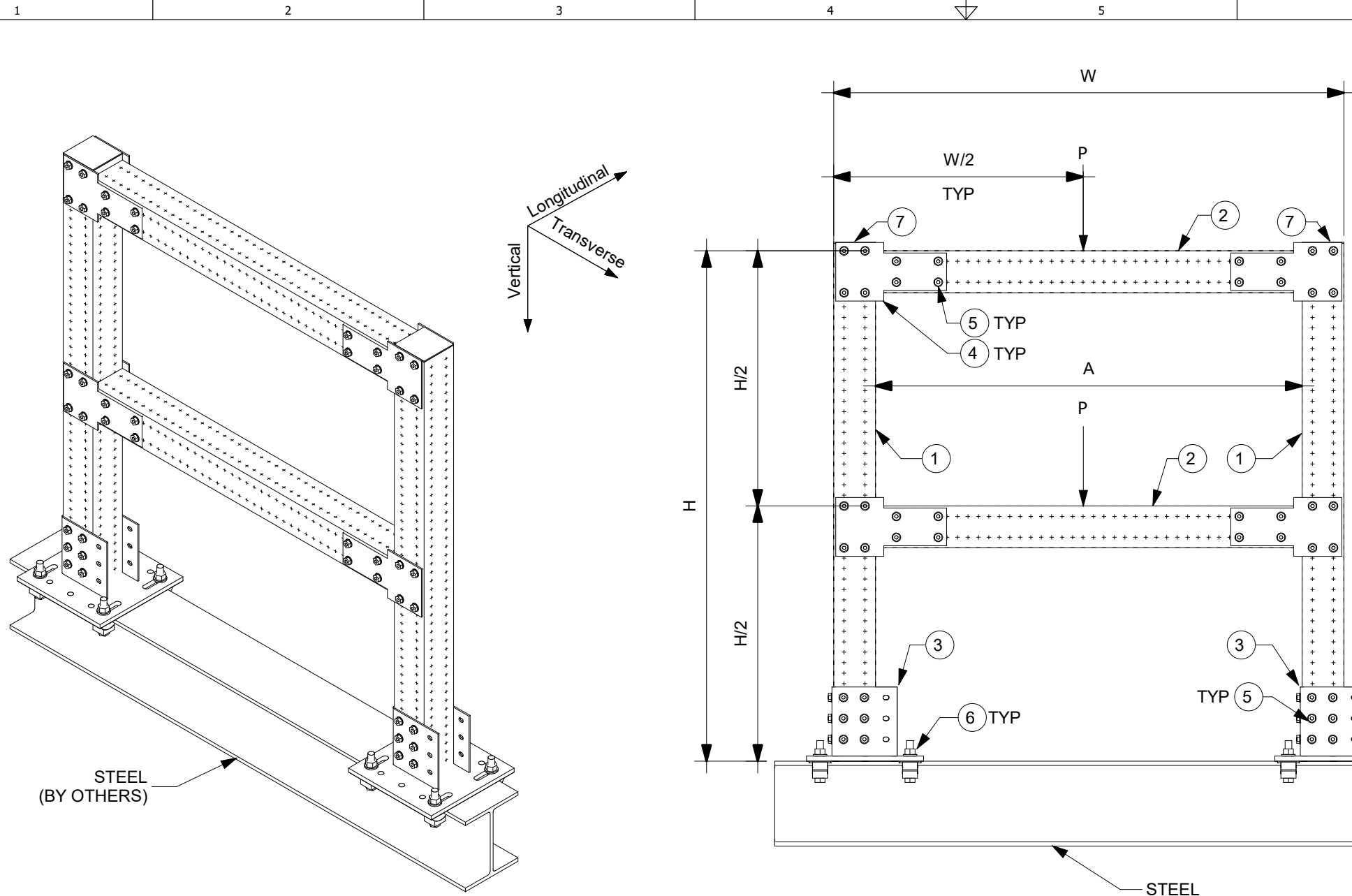

1 ISOMETRIC
N.T.S.

2 ELEVATION
N.T.S.

3 BASEPLATE DETAIL
N.T.S.

MARK	ITEM NO.	DESCRIPTION	QTY.
1	2268369	MT-90 OC	2
2	2268369	MT-90 OC	2
3	VARIABLES	MT-B-GXL S+ OC (SEE TABLE)	2
4	2272075	MT-C-GLP T OC	8
5	2272084	MT-TFB OC	100
6	387398	MI-SGC M16	8
7	2273699	MT-EC-90	2

MT-B-GXL S+ OC		
+	'B' Width	Item No.
1	2.9 to 6.5	2272106
2	6.5 to 9.2	2272107
3	9.2 to 11.8	2272108

NOTE(S):

A. THE TYPICAL SUPPORT IS LOAD RATED AND DIMENSIONALLY LIMITED BASED ON DESIGN METHODOLOGY AND GENERIC NON-PROJECT SPECIFIC ASSUMPTIONS SET FORTH IN PROFIS MODULAR SUPPORTS ENGINEERING SOFTWARE VERSION 1.3. THE ENGINEER OF RECORD SHALL EVALUATE THIS TYPICAL SUPPORT TO DETERMINE ITS SUITABILITY FOR THE ACTUAL PROJECT SPECIFIC DESIGN CRITERIA AND REQUIREMENTS.

B. THE EVALUATION OF EXISTING STRUCTURE IS OUTSIDE OF THE TYPICAL DESIGN SCOPE AND SHALL BE PERFORMED BY THE ENGINEER OF RECORD.

C. TYPICAL SUPPORT DESIGN IS BASED ON INTERNATIONAL BUILDING CODE (IBC) 2018. SEE TABLE-A FOR ALLOWABLE STRENGTH DESIGN LOADS (STATIC U.N.O.); GOVERNING LATERAL LOADS NOTED IN THE ALLOWABLE LOAD TABLE IS MAXIMUM OF 30% OF DEAD LOAD.

D. ALL LOADS ASSUMED TO ACT ON THE SUPPORT, NO ECCENTRICITY CONSIDERED.

E. MAXIMUM ALLOWABLE LOADS NOTED IN TABLE-A ARE BASED ON THE GOVERNING COMBINATION OF VERTICAL LOAD WITH TRANSVERSE LOAD OR VERTICAL LOAD WITH LONGITUDINAL LOAD. A SEPARATE ANALYSIS MUST BE PERFORMED WHEN TRANSVERSE AND LONGITUDINAL LOAD OCCURS SIMULTANEOUSLY.

F. REFER TO HILTI INSTRUCTION FOR USE SHEET FOR REQUIRED INSTALLATION INFORMATION. THREAD FORMING BOLT MAY BE INSTALLED USING A TORQUE WRENCH OR SI-AT-A22 PER INSTRUCTION FOR USE.

TABLE A				
Max H, in	36	48	60	
Max W, in	36	48	60	
Max A, in	28-1/8	40-1/8	52-1/8	
Vertical (P)	2900	2200	1800	
Transverse	870	660	540	
Longitudinal	870	660	540	

ALLOWABLE LOADS, lbs

REVISION HISTORY	
NO:	DESCRIPTION:
A	ISSUE FOR REVIEW
B	NOTE MODIFICATIONS
C	ISSUE FOR REVIEW - NOTE MODIFICATIONS AND DIM CALLOUTS

DATE: 12/18/2020
01/29/2021
05/28/2021

PROJECT NAME: GOAL POST MT90 S 002

PROJECT DESCRIPTION: GOAL POST MT90 S 002

DRAWN: GAB
CHECKED: IDP
DESIGNED: JDR
REVIEWED: BVD

PAPER SIZE: ANSI B

PROJECT NUMBER: GP9S2 - 1

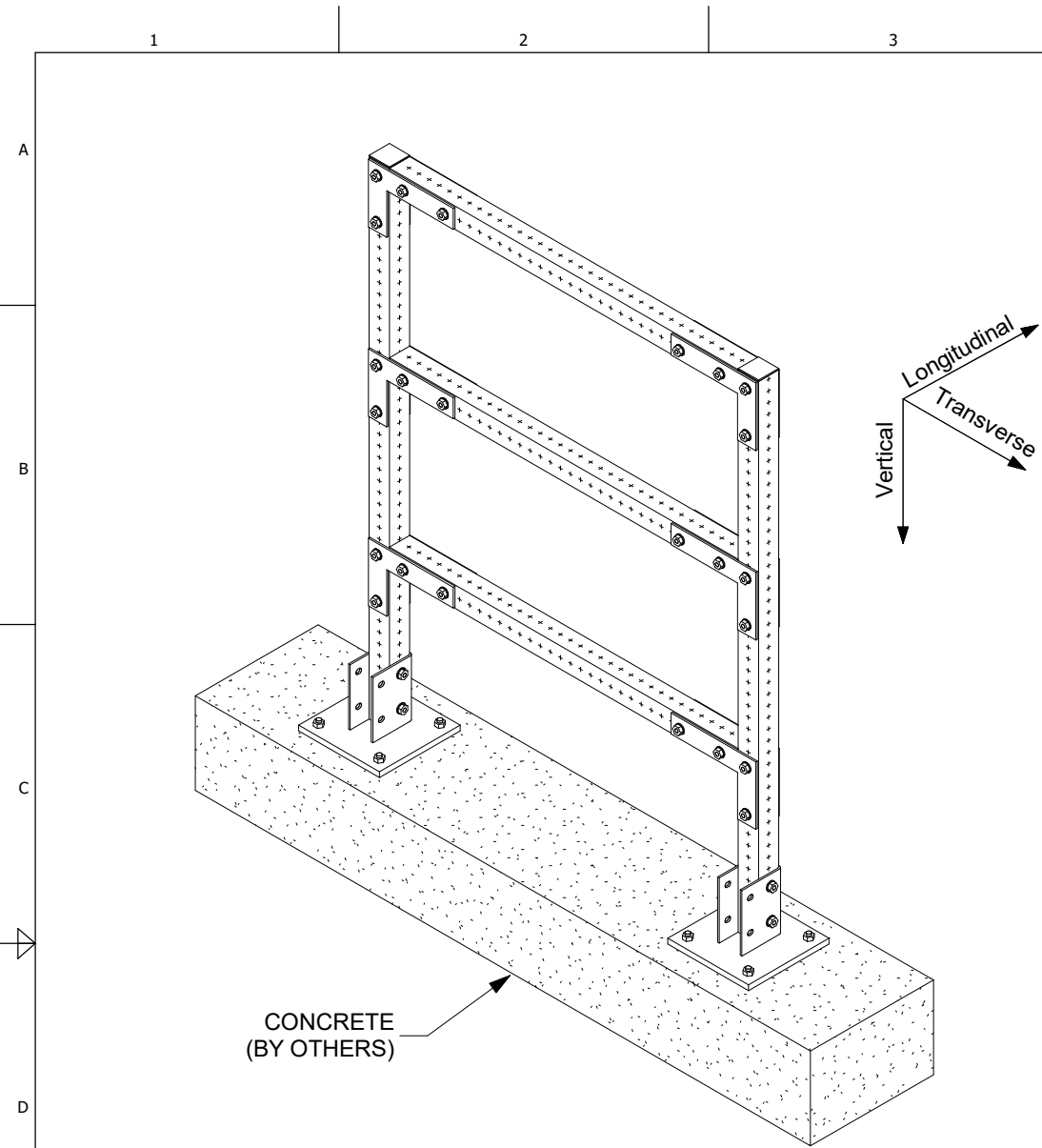

1 ISOMETRIC
N.T.S.

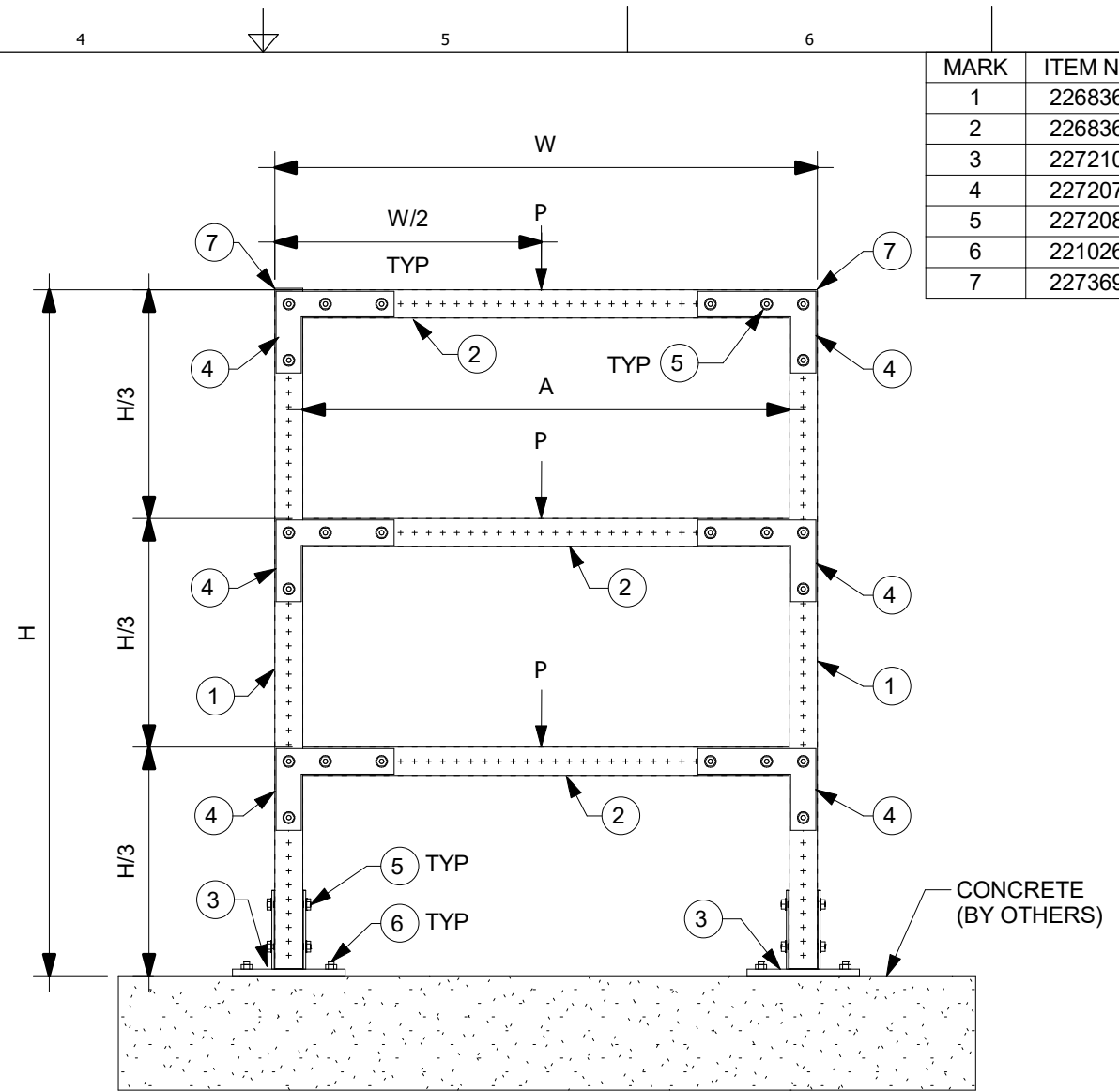

2 ELEVATION
N.T.S.

MARK	ITEM NO.	DESCRIPTION	QTY.
1	2268365	MT-70 OC	2
2	2268365	MT-70 OC	3
3	2272101	MT-B-GS O4U OC	2
4	2272073	MT-C-GSP L OC	12
5	2272084	MT-TFB OC	60
6	2210261	ANCHOR KB-TZ2 1/2" x 4-1/2" SS304	8
7	2273697	MT-EC-70	2

NOTE(S):

A. THE TYPICAL SUPPORT IS LOAD RATED AND DIMENSIONALLY LIMITED BASED ON DESIGN METHODOLOGY AND GENERIC NON-PROJECT SPECIFIC ASSUMPTIONS SET FORTH IN PROFIS MODULAR SUPPORTS ENGINEERING SOFTWARE VERSION 1.3. THE ENGINEER OF RECORD SHALL EVALUATE THIS TYPICAL SUPPORT TO DETERMINE ITS SUITABILITY FOR THE ACTUAL PROJECT SPECIFIC DESIGN CRITERIA AND REQUIREMENTS.

B. THE EVALUATION OF EXISTING STRUCTURE IS OUTSIDE OF THE TYPICAL DESIGN SCOPE AND SHALL BE PERFORMED BY THE ENGINEER OF RECORD.

C. TYPICAL SUPPORT DESIGN IS BASED ON INTERNATIONAL BUILDING CODE (IBC) 2018. SEE TABLE-A FOR ALLOWABLE STRENGTH DESIGN LOADS (STATIC U.N.O.); GOVERNING LATERAL LOADS NOTED IN THE ALLOWABLE LOAD TABLE IS MAXIMUM OF 30% OF DEAD LOAD.

D. ALL LOADS ASSUMED TO ACT ON THE SUPPORT, NO ECCENTRICITY CONSIDERED

E. MAXIMUM ALLOWABLE LOADS NOTED IN TABLE-A ARE BASED ON THE GOVERNING COMBINATION OF VERTICAL LOAD WITH TRANSVERSE LOAD OR VERTICAL LOAD WITH LONGITUDINAL LOAD. A SEPARATE ANALYSIS MUST BE PERFORMED WHEN TRANSVERSE AND LONGITUDINAL LOAD OCCURS SIMULTANEOUSLY.

F. REFER TO HILTI INSTRUCTION FOR USE SHEET FOR REQUIRED INSTALLATION INFORMATION. THREAD FORMING BOLT MAY BE INSTALLED USING A TORQUE WRENCH OR SI-AT-A22 PER INSTRUCTION FOR USE.

G. SEE BOM FOR KWIK BOLT-TZ2 ANCHOR BOLT. FOR 1/2" DIA. HILTI KWIK BOLT-TZ2 USE MIN. 3-1/4" EFFECTIVE EMBEDMENT. FOR 5/8" DIA. KWIK BOLT-TZ2 USE 3-1/4" MIN. EFFECTIVE EMBEDMENT. INSTALL ANCHOR PER ESR-4266 AND HILTI'S INSTRUCTIONS FOR USE AND RECOMMENDATIONS. MIN. CONCRETE COMPRESSIVE STRENGTH $f'_c=3000$ PSI, MIN. CONCRETE EDGE DISTANCE = 6", AND MIN. CONCRETE THICKNESS = 6".

H. CONCRETE ANCHORS NOTED IN THE BILL OF MATERIAL ARE DESIGNED ONLY FOR WIND LATERAL LOADING. ENGINEER OF RECORD TO VERIFY ADEQUACY OF ANCHOR WHEN TYPICAL IS BEING USED FOR SEISMIC LATERAL LOADING.

	24	36	48
Max H, in	24	36	48
Max W, in	24	36	48
Max A, in	20-1/8	32-1/8	44-1/8
Vertical (P)	1200	675	375
Transverse	360	203	113
Longitudinal	360	203	113

ALLOWABLE LOADS, lbs

REVISION HISTORY		DATE:	
NO:	DESCRIPTION:		
B	ISSUE FOR REVIEW	12/14/2020	
C	ISSUE FOR BU USE	07/06/2021	
D	ANCHOR NOTE AND BOM MODIFICATION FOR ANCHOR	03/22/2022	

PROJECT NAME: GOAL POST MT70 C 003

PROJECT DESCRIPTION: GOAL POST MT70 C 003

ANSI B

HILTI

DRAWN:	CHECKED:	DESIGNED:	REVIEWED:
GAB	IDP	JDR	BVD
PAPER SIZE: ANSI B		PROJECT NUMBER: GP7C3 - 1	

MARK	ITEM NO.	DESCRIPTION	QTY.
1	2268365	MT-70 OC	2
2	2268365	MT-70 OC	1
3	2272101	MT-B-GS O4U OC	2
4	2272073	MT-C-GSP L OC	4
5	2272084	MT-TFB OC	28
6	2273697	MT-EC-70	2
7	2210261	ANCHOR KB-TZ2 1/2" x 4-1/2" SS304	8

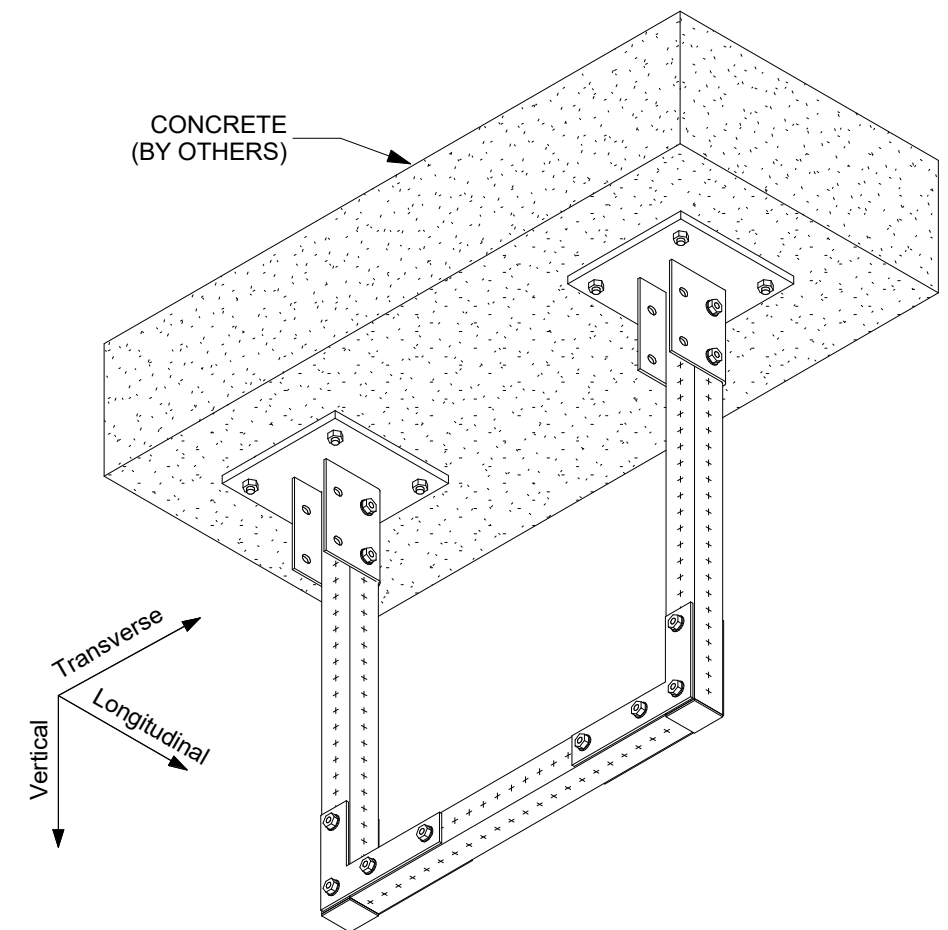

1 ISOMETRIC
N.T.S.

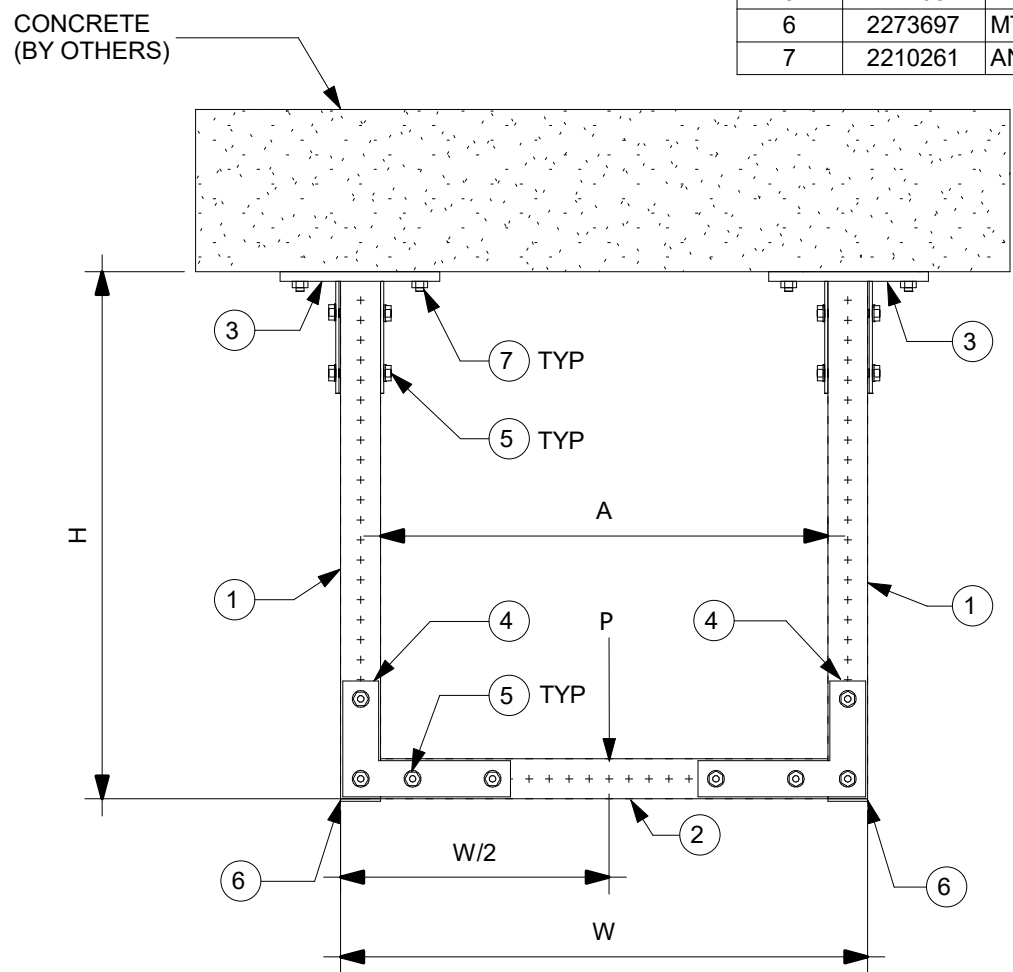

2 ELEVATION
N.T.S.

NOTE(S):

A. THE TYPICAL SUPPORT IS LOAD RATED AND DIMENSIONALLY LIMITED BASED ON DESIGN METHODOLOGY AND GENERIC NON-PROJECT SPECIFIC ASSUMPTIONS SET FORTH IN PROFIS MODULAR SUPPORTS ENGINEERING SOFTWARE VERSION 1.3. THE ENGINEER OF RECORD SHALL EVALUATE THIS TYPICAL SUPPORT TO DETERMINE ITS SUITABILITY FOR THE ACTUAL PROJECT SPECIFIC DESIGN CRITERIA AND REQUIREMENTS.

B. THE EVALUATION OF EXISTING STRUCTURE IS OUTSIDE OF THE TYPICAL DESIGN SCOPE AND SHALL BE PERFORMED BY THE ENGINEER OF RECORD.

C. TYPICAL SUPPORT DESIGN IS BASED ON INTERNATIONAL BUILDING CODE (IBC) 2018. SEE TABLE-A FOR ALLOWABLE STRENGTH DESIGN LOADS (STATIC U.N.O.); GOVERNING LATERAL LOADS NOTED IN THE ALLOWABLE LOAD TABLE IS MAXIMUM OF 30% OF DEAD LOAD.

D. ALL LOADS ASSUMED TO ACT ON THE SUPPORT, NO ECCENTRICITY CONSIDERED

E. MAXIMUM ALLOWABLE LOADS NOTED IN TABLE-A ARE BASED ON THE GOVERNING COMBINATION OF VERTICAL LOAD WITH TRANSVERSE LOAD OR VERTICAL LOAD WITH LONGITUDINAL LOAD. A SEPARATE ANALYSIS MUST BE PERFORMED WHEN TRANSVERSE AND LONGITUDINAL LOAD OCCURS SIMULTANEOUSLY.

F. REFER TO HILTI INSTRUCTION FOR USE SHEET FOR REQUIRED INSTALLATION INFORMATION.

G. SEE BOM FOR KWIK BOLT-TZ2 ANCHOR BOLT. FOR 1/2" DIA. HILTI KWIK BOLT-TZ2 USE MIN. 3-1/4" EFFECTIVE EMBEDMENT. FOR 5/8" DIA. KWIK BOLT-TZ2 USE 3-1/4" MIN. EFFECTIVE EMBEDMENT. INSTALL ANCHOR PER ESR-4266 AND HILTI'S INSTRUCTIONS FOR USE AND RECOMMENDATIONS. MIN. CONCRETE COMPRESSIVE STRENGTH $f'_c=3000$ PSI, MIN. CONCRETE EDGE DISTANCE = 6", AND MIN. CONCRETE THICKNESS = 6".

H. CONCRETE ANCHORS NOTED IN THE BILL OF MATERIAL ARE DESIGNED ONLY FOR WIND LATERAL LOADING. ENGINEER OF RECORD TO VERIFY ADEQUACY OF ANCHOR WHEN TYPICAL IS BEING USED FOR SEISMIC LATERAL LOADING.

	24	36	48
Max H, in	24	36	48
Max W, in	24	36	48
Max A, in	20-1/8	32-1/8	44-1/8
Vertical (P)	1400	925	625
Transverse	420	277	187
Longitudinal	420	277	187

ALLOWABLE LOADS, lbs

REVISION HISTORY		
NO.	DESCRIPTION:	DATE:
B	ISSUE FOR REVIEW	03/03/2021
C	ISSUE FOR BU USE	07/06/2021
D	ANCHOR NOTE AND BOM MODIFICATION FOR ANCHOR	03/22/2022

PROJECT NAME: TRAPEZE MT70 C 002

PROJECT DESCRIPTION: TRAPEZE MT70 C 002

DRAWN:	CHECKED:	DESIGNED:	REVIEWED:
GAB	IDP	JDR	BVD
PAPER SIZE:	PROJECT NUMBER:		
ANSI B	PROJECT	JOB	SHEET
	- TR7C2 -		1

MARK	ITEM NO.	DESCRIPTION	QTY.
1	2268365	MT-70 OC	2
2	2268365	MT-70 OC	1
3	2272101	MT-B-GS O4U OC	2
4	2272073	MT-C-GSP L OC	4
5	2272084	MT-TFB OC	28
6	2273697	MT-EC-70	2
7	2194341	X-BT-MR W10/15 SN 8	8

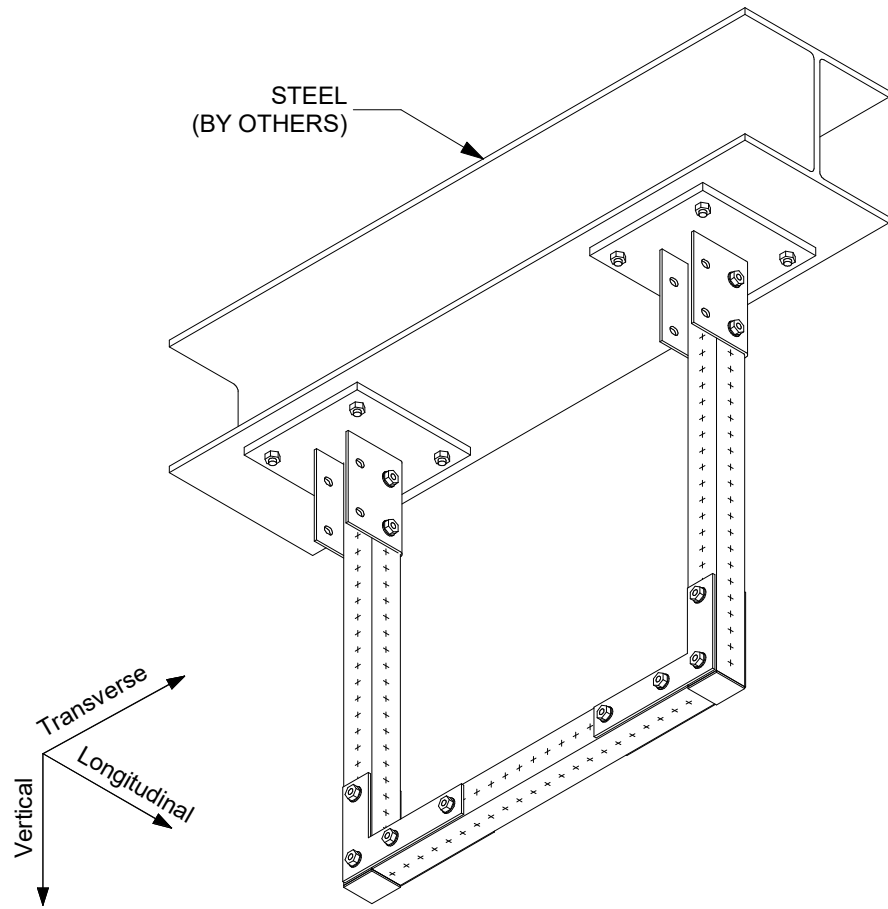

1 ISOMETRIC
N.T.S.

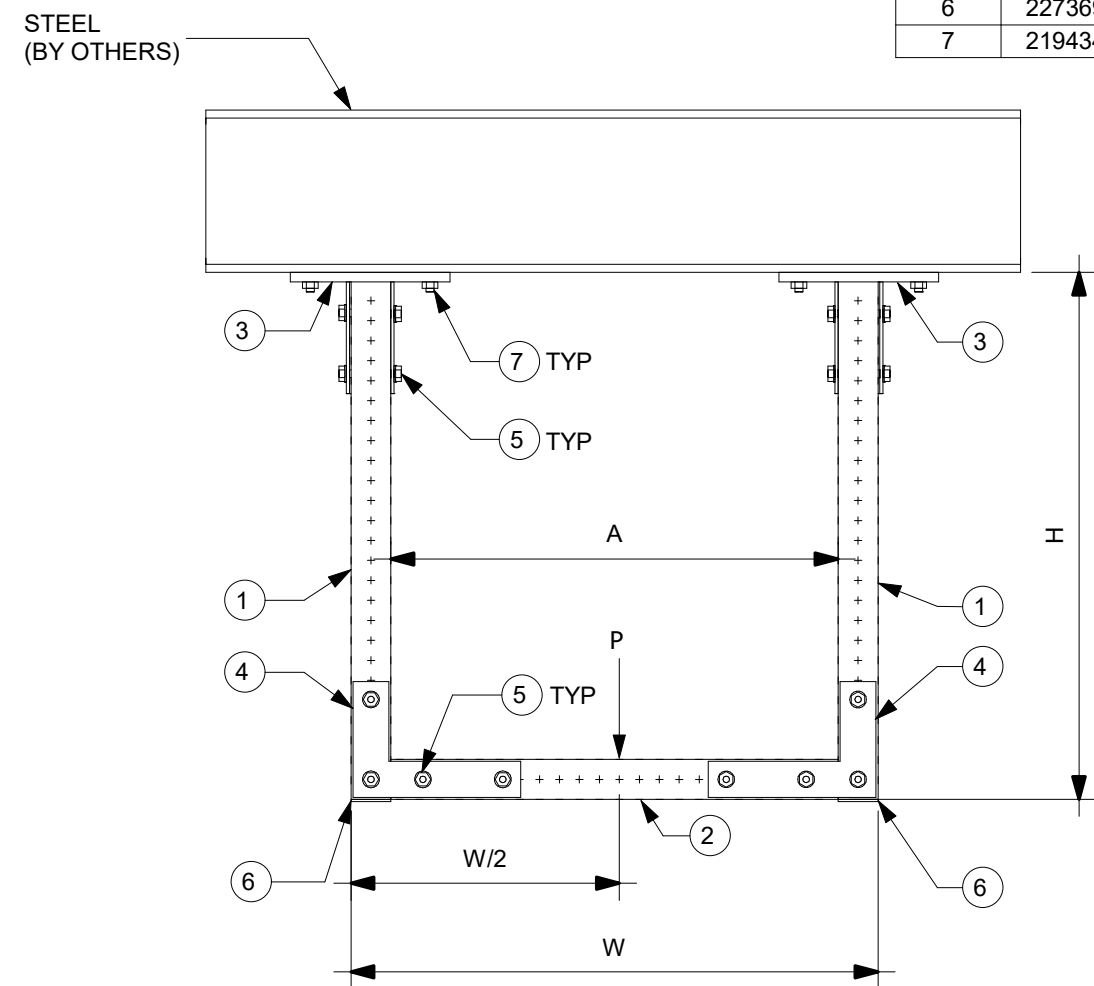

2 ELEVATION
N.T.S.

NOTE(S):

A. THE TYPICAL SUPPORT IS LOAD RATED AND DIMENSIONALLY LIMITED BASED ON DESIGN METHODOLOGY AND GENERIC NON-PROJECT SPECIFIC ASSUMPTIONS SET FORTH IN PROFIS MODULAR SUPPORTS ENGINEERING SOFTWARE VERSION 1.3. THE ENGINEER OF RECORD SHALL EVALUATE THIS TYPICAL SUPPORT TO DETERMINE ITS SUITABILITY FOR THE ACTUAL PROJECT SPECIFIC DESIGN CRITERIA AND REQUIREMENTS.

B. THE EVALUATION OF EXISTING STRUCTURE IS OUTSIDE OF THE TYPICAL DESIGN SCOPE AND SHALL BE PERFORMED BY THE ENGINEER OF RECORD.

C. TYPICAL SUPPORT DESIGN IS BASED ON INTERNATIONAL BUILDING CODE (IBC) 2018. SEE TABLE-A FOR ALLOWABLE STRENGTH DESIGN LOADS (STATIC U.N.O.); GOVERNING LATERAL LOADS NOTED IN THE ALLOWABLE LOAD TABLE IS MAXIMUM OF 30% OF DEAD LOAD.

D. ALL LOADS ASSUMED TO ACT ON THE SUPPORT, NO ECCENTRICITY CONSIDERED.

E. MAXIMUM ALLOWABLE LOADS NOTED IN TABLE-A ARE BASED ON THE GOVERNING COMBINATION OF VERTICAL LOAD WITH TRANSVERSE LOAD OR VERTICAL LOAD WITH LONGITUDINAL LOAD. A SEPARATE ANALYSIS MUST BE PERFORMED WHEN TRANSVERSE AND LONGITUDINAL LOAD OCCURS SIMULTANEOUSLY.

F. REFER TO HILTI INSTRUCTION FOR USE SHEET FOR REQUIRED INSTALLATION INFORMATION. THREAD FORMING BOLT MAY BE INSTALLED USING A TORQUE WRENCH OR SI-AT-A22 PER INSTRUCTION FOR USE.

G. X-BT REQUIREMENT: MIN. STEEL BASE MATERIAL THICKNESS SHALL BE 5/16". MIN EDGE DISTANCE SHALL BE 3/8". MIN YIELD STRENGTH OF STEEL SHALL BE FY=36KSI.

H. MINIMUM 8" FLANGE WIDTH REQUIRED.

	24	36	48
Max H, in	24	36	48
Max W, in	24	36	48
Max A, in	20-1/8	32-1/8	44-1/8
Vertical (P)	1400	925	625
Transverse	420	277	187
Longitudinal	420	277	187

ALLOWABLE LOADS, lbs

REVISION HISTORY			
NO:	DESCRIPTION:	DATE:	
A	ISSUE FOR REVIEW	12/14/2020	
B	ISSUE FOR REVIEW - NOTE MODIFICATIONS AND DIM CALLOUTS	03/03/2021	
C	ISSUE FOR REVIEW - NOTE MODIFICATIONS AND DIM CALLOUTS	05/28/2021	

PROJECT NAME: TRAPEZE MT70 S 002

DRAWN:	CHECKED:	DESIGNED:	REVIEWED:
GAB	IDP	JDR	BVD

PROJECT DESCRIPTION: TRAPEZE MT70 S 002

PAPER SIZE: ANSI B	PROJECT NUMBER:		
	PROJECT	JOB	SHEET
	- TR7S2 -		1

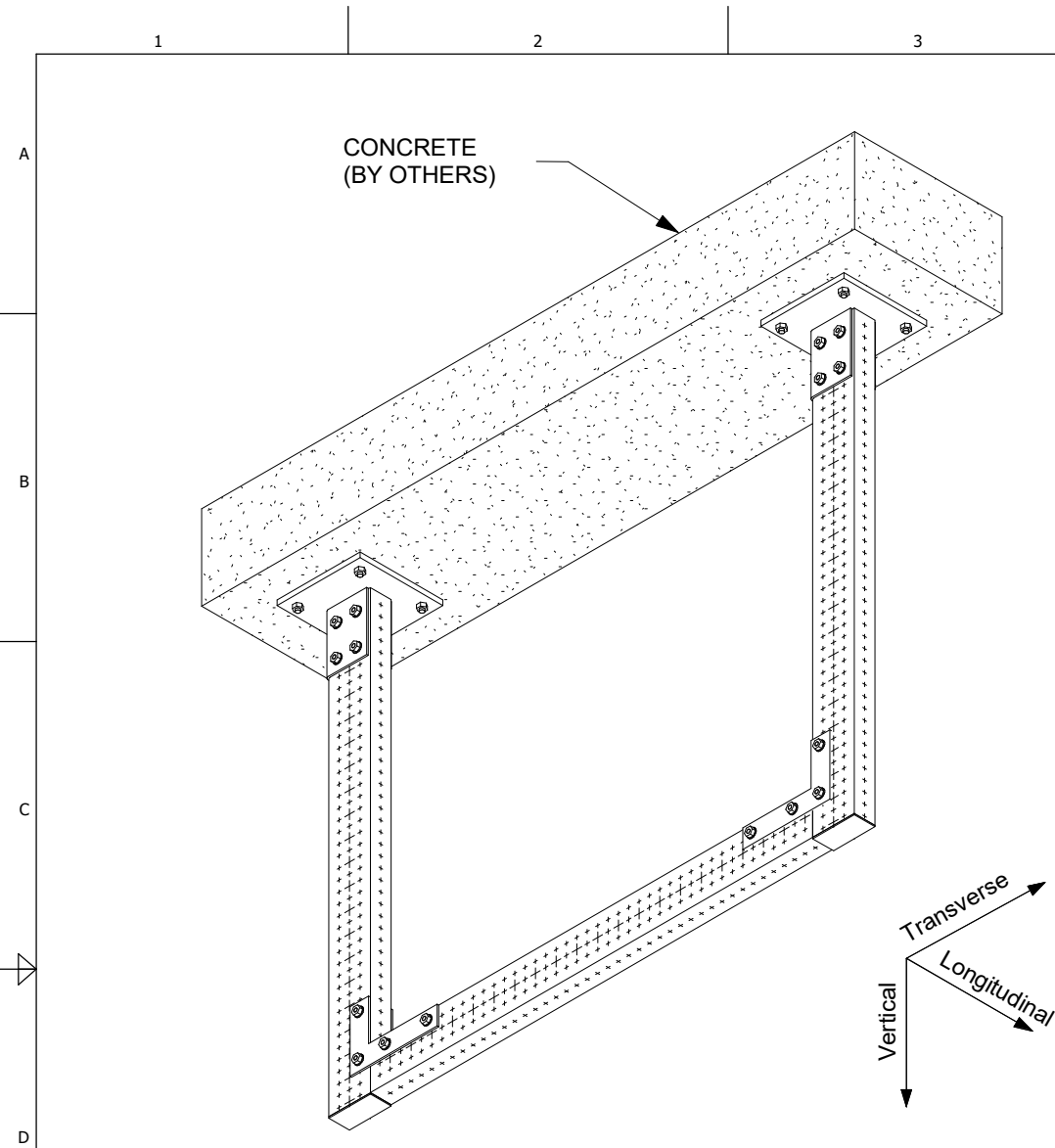

1 ISOMETRIC
N.T.S.

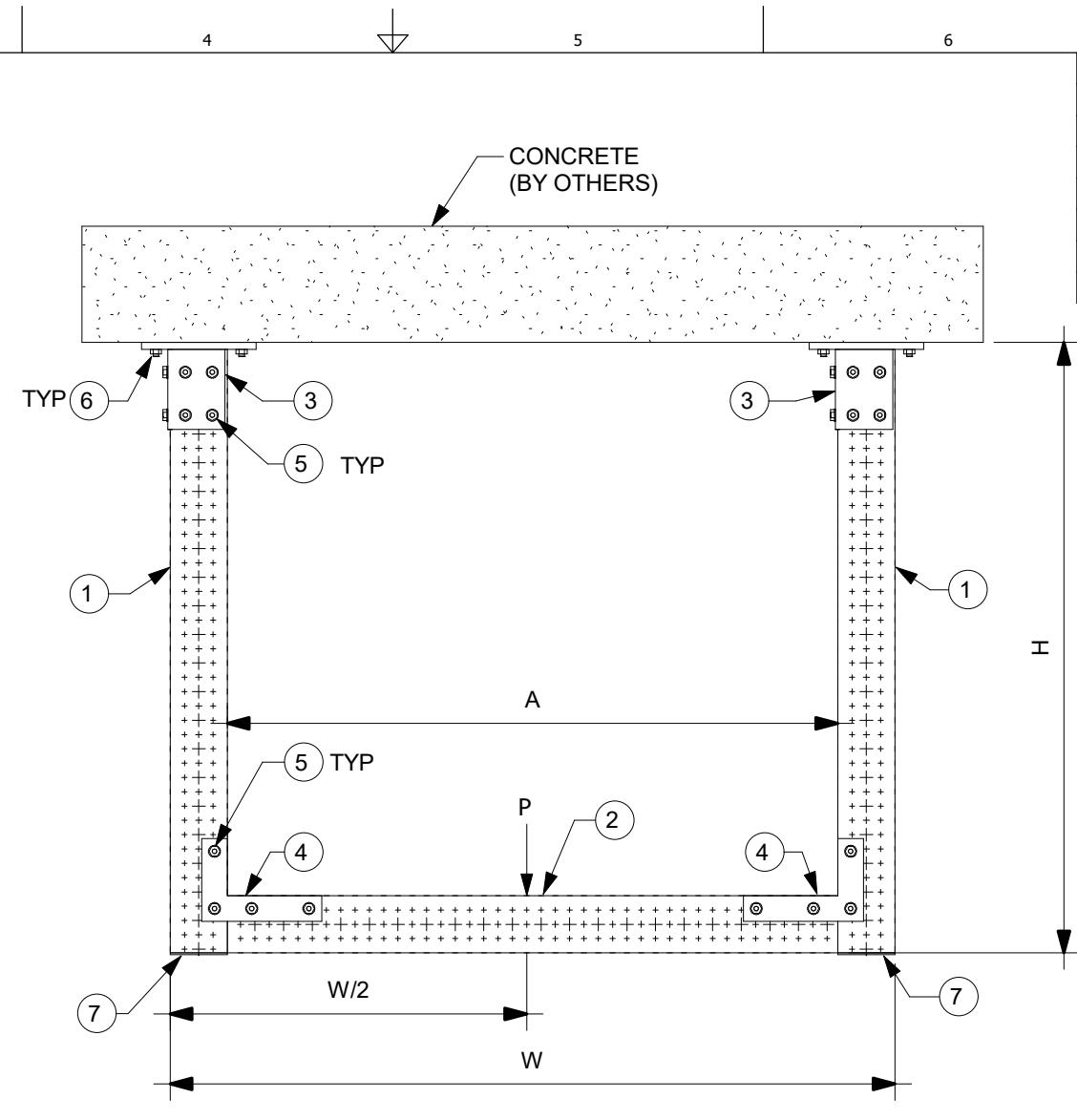

2 ELEVATION
N.T.S.

MARK	ITEM NO.	DESCRIPTION	QTY.
1	2268367	MT-80 OC	2
2	2268367	MT-80 OC	1
3	2272101	MT-B-GS O4U OC	2
4	2272073	MT-C-GSP L OC	4
5	2272084	MT-TFB OC	36
6	2210261	ANCHOR KB-TZ2 1/2" x 4-1/2" SS304	8
7	2273698	MT-EC-80	2

NOTE(S):

A. THE TYPICAL SUPPORT IS LOAD RATED AND DIMENSIONALLY LIMITED BASED ON DESIGN METHODOLOGY AND GENERIC NON-PROJECT SPECIFIC ASSUMPTIONS SET FORTH IN PROFIS MODULAR SUPPORTS ENGINEERING SOFTWARE VERSION 1.3. THE ENGINEER OF RECORD SHALL EVALUATE THIS TYPICAL SUPPORT TO DETERMINE ITS SUITABILITY FOR THE ACTUAL PROJECT SPECIFIC DESIGN CRITERIA AND REQUIREMENTS.

B. THE EVALUATION OF EXISTING STRUCTURE IS OUTSIDE OF THE TYPICAL DESIGN SCOPE AND SHALL BE PERFORMED BY THE ENGINEER OF RECORD.

C. TYPICAL SUPPORT DESIGN IS BASED ON INTERNATIONAL BUILDING CODE (IBC) 2018. SEE TABLE-A FOR ALLOWABLE STRENGTH DESIGN LOADS (STATIC U.N.O.); GOVERNING LATERAL LOADS NOTED IN THE ALLOWABLE LOAD TABLE IS MAXIMUM OF 30% OF DEAD LOAD.

D. ALL LOADS ASSUMED TO ACT ON THE SUPPORT, NO ECCENTRICITY CONSIDERED

E. MAXIMUM ALLOWABLE LOADS NOTED IN TABLE-A ARE BASED ON THE GOVERNING COMBINATION OF VERTICAL LOAD WITH TRANSVERSE LOAD OR VERTICAL LOAD WITH LONGITUDINAL LOAD. A SEPARATE ANALYSIS MUST BE PERFORMED WHEN TRANSVERSE AND LONGITUDINAL LOAD OCCURS SIMULTANEOUSLY.

F. REFER TO HILTI INSTRUCTION FOR USE SHEET FOR REQUIRED INSTALLATION INFORMATION.

G. SEE BOM FOR KWIK BOLT-TZ2 ANCHOR BOLT. FOR 1/2" DIA. HILTI KWIK BOLT-TZ2 USE MIN. 3-1/4" EFFECTIVE EMBEDMENT. FOR 5/8" DIA. KWIK BOLT-TZ2 USE 3-1/4" MIN. EFFECTIVE EMBEDMENT. INSTALL ANCHOR PER ESR-4266 AND HILTI'S INSTRUCTIONS FOR USE AND RECOMMENDATIONS. MIN. CONCRETE COMPRESSIVE STRENGTH $f'_c=3000$ PSI, MIN. CONCRETE EDGE DISTANCE = 6", AND MIN. CONCRETE THICKNESS = 6".

H. CONCRETE ANCHORS NOTED IN THE BILL OF MATERIAL ARE DESIGNED ONLY FOR WIND LATERAL LOADING. ENGINEER OF RECORD TO VERIFY ADEQUACY OF ANCHOR WHEN TYPICAL IS BEING USED FOR SEISMIC LATERAL LOADING.

	24	36	48
Max H, in	24	36	48
Max W, in	24	36	48
Max A, in	16-1/8	28-1/8	40-1/8
Vertical (P)	2300	1600	950
Transverse	690	480	285
Longitudinal	690	480	285

ALLOWABLE LOADS, lbs

REVISION HISTORY		DATE:	
NO:	DESCRIPTION:		
B	ISSUE FOR REVIEW - UPDATED DIMENSIONS	03/03/2021	
C	ISSUE FOR BU USE	07/06/2021	
D	ANCHOR NOTE AND BOM MODIFICATION FOR ANCHOR	03/22/2022	

PROJECT NAME: TRAPEZE MT80 C 001

PROJECT DESCRIPTION: TRAPEZE MT80 C 001

GAB	IDP	JDR	BVD
PAPER SIZE: ANSI B	PROJECT NUMBER:		
	PROJECT	JOB	SHEET
	- TR8C1 -	1	

1 2 3 4 5 6 7 8

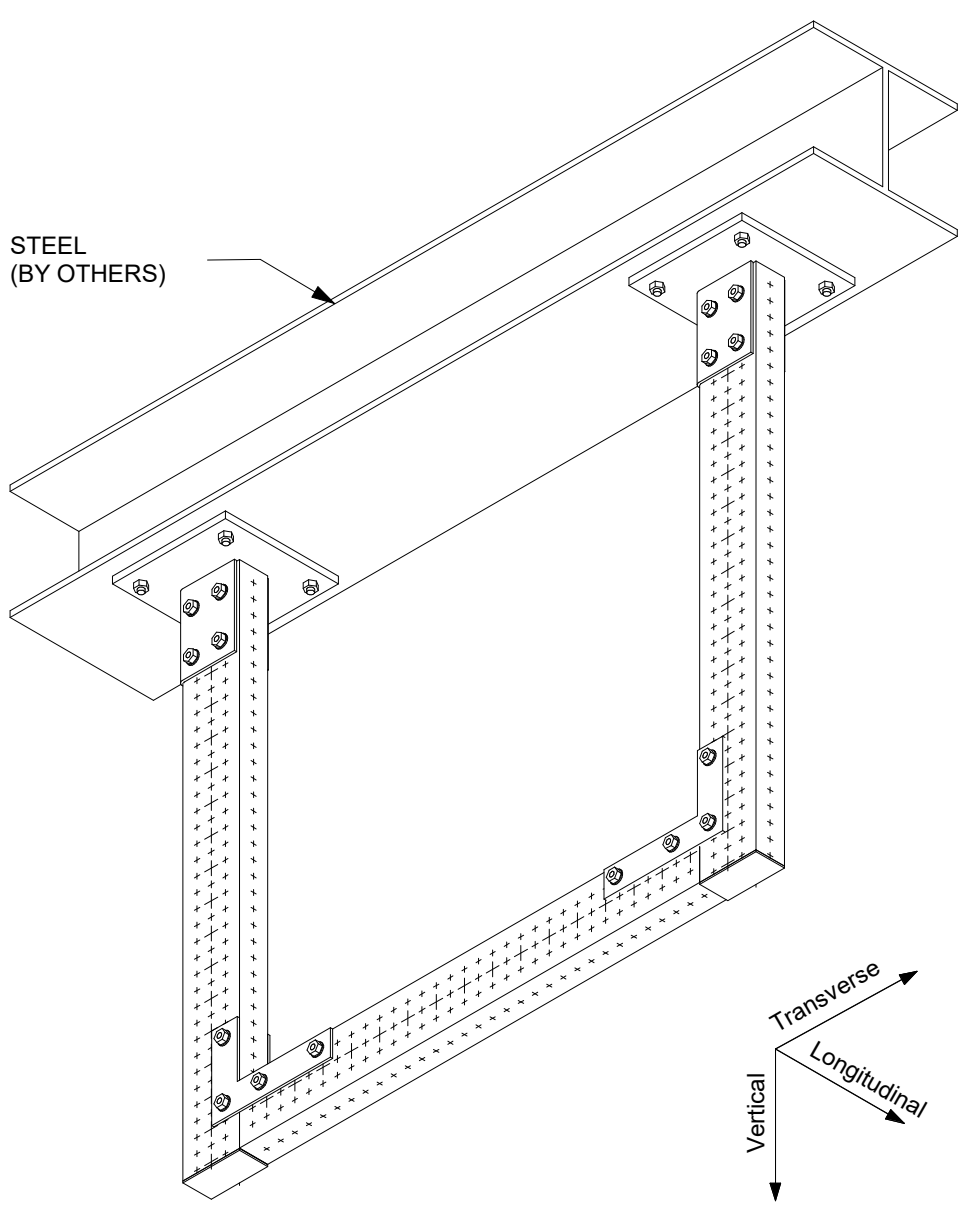

1 ISOMETRIC
N.T.S.

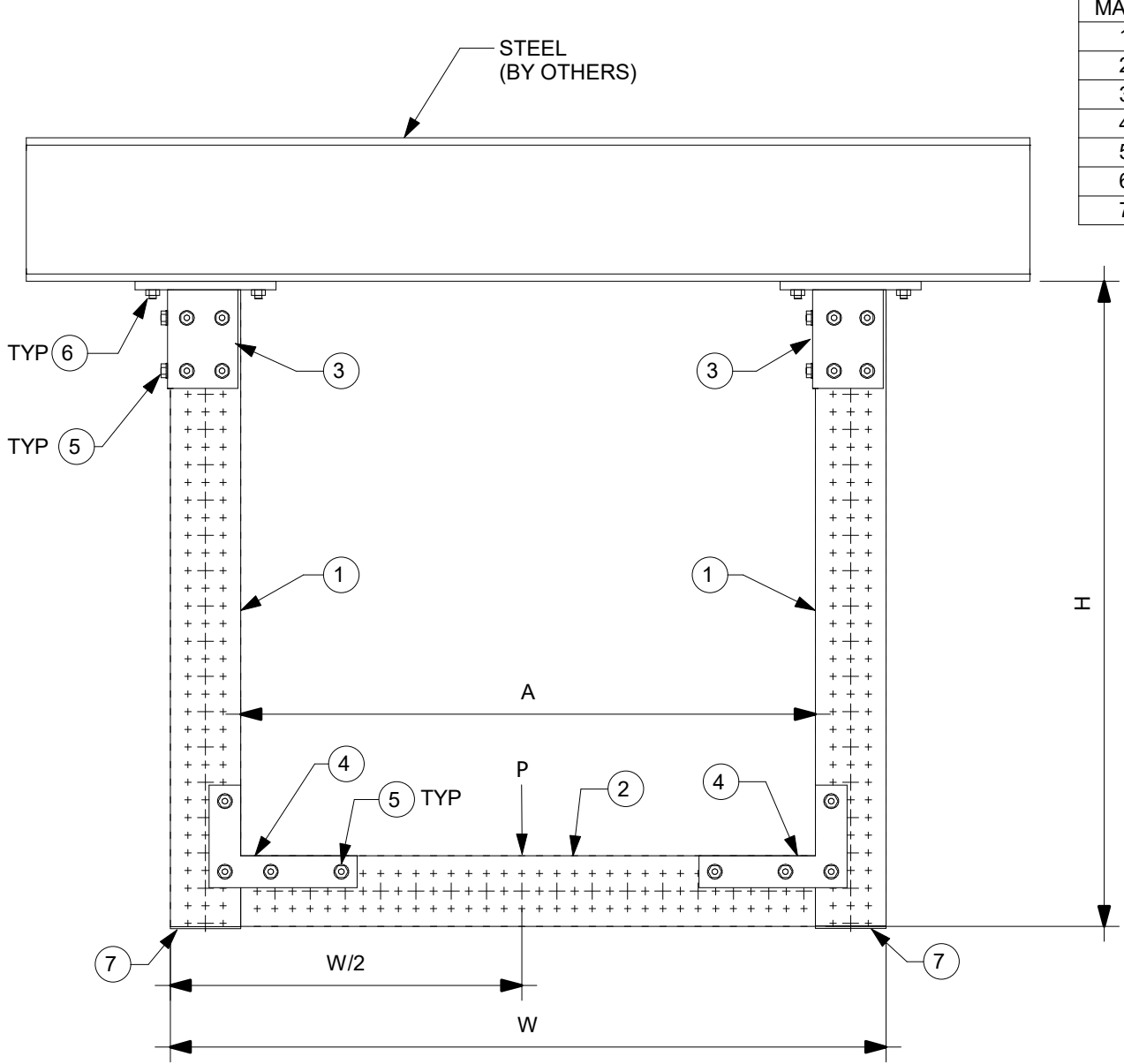

2 ELEVATION
N.T.S.

MARK	ITEM NO.	DESCRIPTION	QTY.
1	2268367	MT-80 OC	2
2	2268367	MT-80 OC	1
3	2272101	MT-B-GS O4U OC	2
4	2272073	MT-C-GSP L OC	4
5	2272084	MT-TFB OC	36
6	2194341	X-BT-MR W10/15 SN 8	8
7	2273698	MT-EC-80	2

NOTE(S):

A. THE TYPICAL SUPPORT IS LOAD RATED AND DIMENSIONALLY LIMITED BASED ON DESIGN METHODOLOGY AND GENERIC NON-PROJECT SPECIFIC ASSUMPTIONS SET FORTH IN PROFIS MODULAR SUPPORTS ENGINEERING SOFTWARE VERSION 1.3. THE ENGINEER OF RECORD SHALL EVALUATE THIS TYPICAL SUPPORT TO DETERMINE ITS SUITABILITY FOR THE ACTUAL PROJECT SPECIFIC DESIGN CRITERIA AND REQUIREMENTS.

B. THE EVALUATION OF EXISTING STRUCTURE IS OUTSIDE OF THE TYPICAL DESIGN SCOPE AND SHALL BE PERFORMED BY THE ENGINEER OF RECORD.

C. TYPICAL SUPPORT DESIGN IS BASED ON INTERNATIONAL BUILDING CODE (IBC) 2018. SEE TABLE-A FOR ALLOWABLE STRENGTH DESIGN LOADS (STATIC U.N.O.); GOVERNING LATERAL LOADS NOTED IN THE ALLOWABLE LOAD TABLE IS MAXIMUM OF 30% OF DEAD LOAD.

D. ALL LOADS ASSUMED TO ACT ON THE SUPPORT, NO ECCENTRICITY CONSIDERED.

E. MAXIMUM ALLOWABLE LOADS NOTED IN TABLE-A ARE BASED ON THE GOVERNING COMBINATION OF VERTICAL LOAD WITH TRANSVERSE LOAD OR VERTICAL LOAD WITH LONGITUDINAL LOAD. A SEPARATE ANALYSIS MUST BE PERFORMED WHEN TRANSVERSE AND LONGITUDINAL LOAD OCCURS SIMULTANEOUSLY.

F. REFER TO HILTI INSTRUCTION FOR USE SHEET FOR REQUIRED INSTALLATION INFORMATION. THREAD FORMING BOLT MAY BE INSTALLED USING A TORQUE WRENCH OR SI-AT-A22 PER INSTRUCTION FOR USE.

G. X-BT REQUIREMENT: MIN. STEEL BASE MATERIAL THICKNESS SHALL BE 5/16". MIN EDGE DISTANCE SHALL BE 3/8". MIN YIELD STRENGTH OF STEEL SHALL BE $F_y=36KSI$.

H. MINIMUM 8" FLANGE WIDTH REQUIRED.

	24	36	48
Max H, in	24	36	48
Max W, in	24	36	48
Max A, in	20-1/8	32-1/8	44-1/8
Vertical (P)	1660	1200	950
Transverse	495	360	285
Longitudinal	495	360	285

ALLOWABLE LOADS, lbs

REVISION HISTORY		
NO.	DESCRIPTION:	DATE:
A	ISSUE FOR REVIEW	10/09/2020
B	ISSUE FOR REVIEW	12/14/2020
C	ISSUE FOR REVIEW - NOTE MODIFICATIONS AND DIM CALLOUTS	05/28/2021

PROJECT NAME: TRAPEZE MT80 S 001

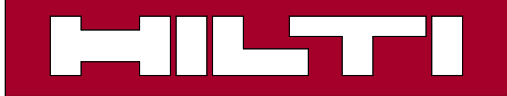

PROJECT DESCRIPTION: TRAPEZE MT80 S 001

DRAWN:	CHECKED:	DESIGNED:	REVIEWED:
MDH	IDP	JDR	BVD
PAPER SIZE:	PROJECT NUMBER:		
ANSI B	PROJECT	JOB	SHEET
	- TR8S1 -		1

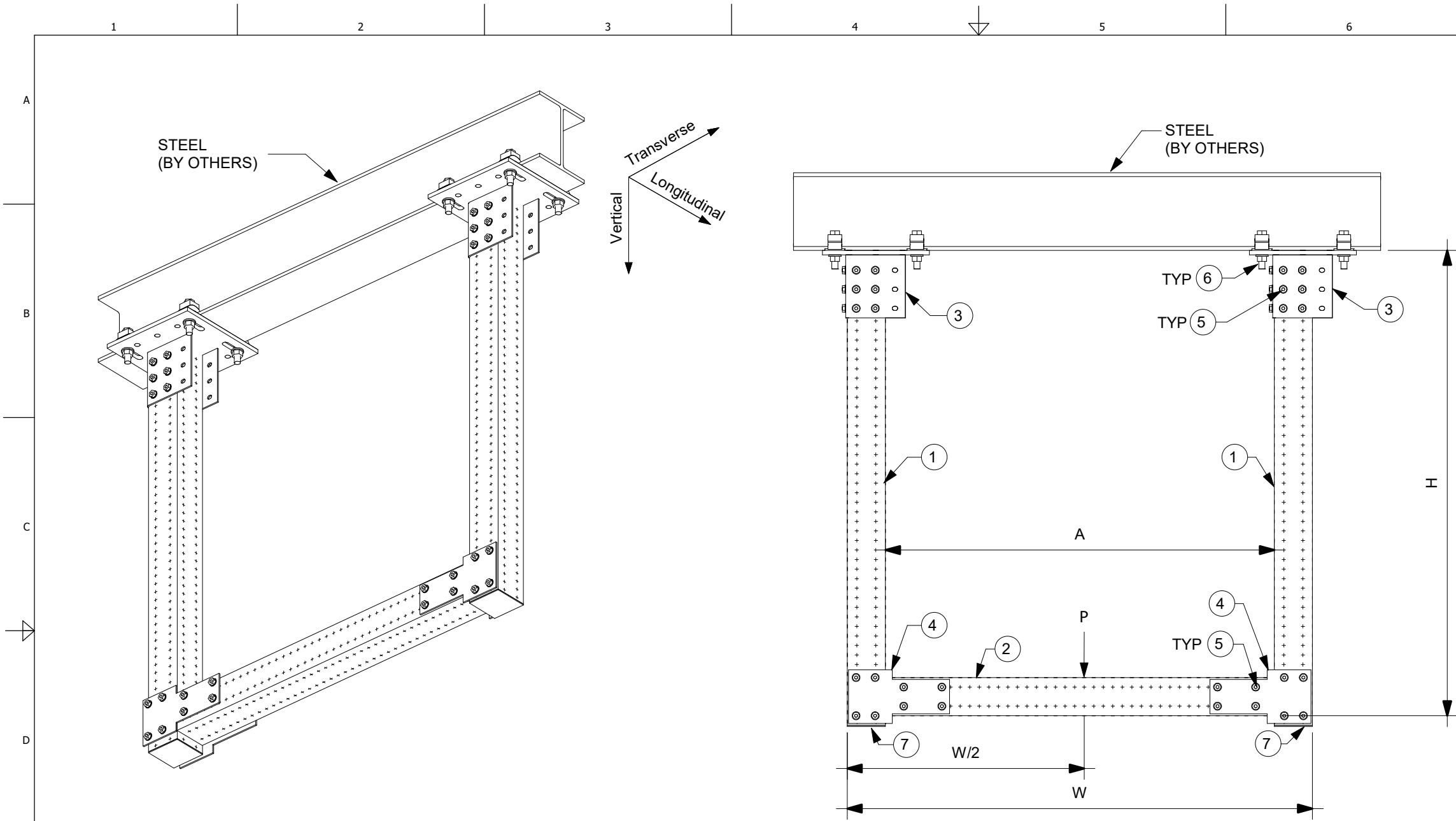

MARK	ITEM NO.	DESCRIPTION	QTY.
1	2268369	MT-90 OC	2
2	2268369	MT-90 OC	1
3	VARIABLES	MT-B-GXL S+ OC (SEE TABLE)	2
4	2272075	MT-C-GLP T OC	4
5	2272084	MT-TFB OC	68
6	387398	MI-SGC M16	8
7	2273699	MT-EC-90	2

MT-B-GXL S+ OC		
+	'B' Width	Item No.
1	2.9 to 6.5	2272106
2	6.5 to 9.2	2272107
3	9.2 to 11.8	2272108

1 ISOMETRIC
N.T.S.

2 ELEVATION
N.T.S.

3 BASEPLATE DETAIL
N.T.S.

NOTE(S):

A. THE TYPICAL SUPPORT IS LOAD RATED AND DIMENSIONALLY LIMITED BASED ON DESIGN METHODOLOGY AND GENERIC NON-PROJECT SPECIFIC ASSUMPTIONS SET FORTH IN PROFIS MODULAR SUPPORTS ENGINEERING SOFTWARE VERSION 1.3. THE ENGINEER OF RECORD SHALL EVALUATE THIS TYPICAL SUPPORT TO DETERMINE ITS SUITABILITY FOR THE ACTUAL PROJECT SPECIFIC DESIGN CRITERIA AND REQUIREMENTS.

B. THE EVALUATION OF EXISTING STRUCTURE IS OUTSIDE OF THE TYPICAL DESIGN SCOPE AND SHALL BE PERFORMED BY THE ENGINEER OF RECORD.

C. TYPICAL SUPPORT DESIGN IS BASED ON INTERNATIONAL BUILDING CODE (IBC) 2018. SEE TABLE-A FOR ALLOWABLE STRENGTH DESIGN LOADS (STATIC U.N.O.); GOVERNING LATERAL LOADS NOTED IN THE ALLOWABLE LOAD TABLE IS MAXIMUM OF 30% OF DEAD LOAD.

D. ALL LOADS ASSUMED TO ACT ON THE SUPPORT, NO ECCENTRICITY CONSIDERED.

E. MAXIMUM ALLOWABLE LOADS NOTED IN TABLE-A ARE BASED ON THE GOVERNING COMBINATION OF VERTICAL LOAD WITH TRANSVERSE LOAD OR VERTICAL LOAD WITH LONGITUDINAL LOAD. A SEPARATE ANALYSIS MUST BE PERFORMED WHEN TRANSVERSE AND LONGITUDINAL LOAD OCCURS SIMULTANEOUSLY.

F. REFER TO HILTI INSTRUCTION FOR USE SHEET FOR REQUIRED INSTALLATION INFORMATION. THREAD FORMING BOLT MAY BE INSTALLED USING A TORQUE WRENCH OR SI-AT-A22 PER INSTRUCTION FOR USE.

TABLE A				
	Max H, in	36	48	60
	Max W, in	36	48	60
	Max A, in	28-1/8	40-1/8	52-1/8
ALLOWABLE LOADS, lbs	Vertical (P)	3000	2500	2200
	Transverse	900	750	660
	Longitudinal	900	750	660

REVISION HISTORY	
NO:	DESCRIPTION:
A	ISSUE FOR REVIEW
B	NOTE MODIFICATIONS
C	ISSUE FOR REVIEW - NOTE MODIFICATIONS AND DIM CALLOUTS

PROJECT NAME: TRAPEZE MT90 S 002

PROJECT DESCRIPTION: TRAPEZE MT90 S 002

DRAWN:	CHECKED:	DESIGNED:	REVIEWED:
GAB	IDP	JDR	BVD

PAPER SIZE: ANSI B

PROJECT NUMBER: TR9S2 - 1

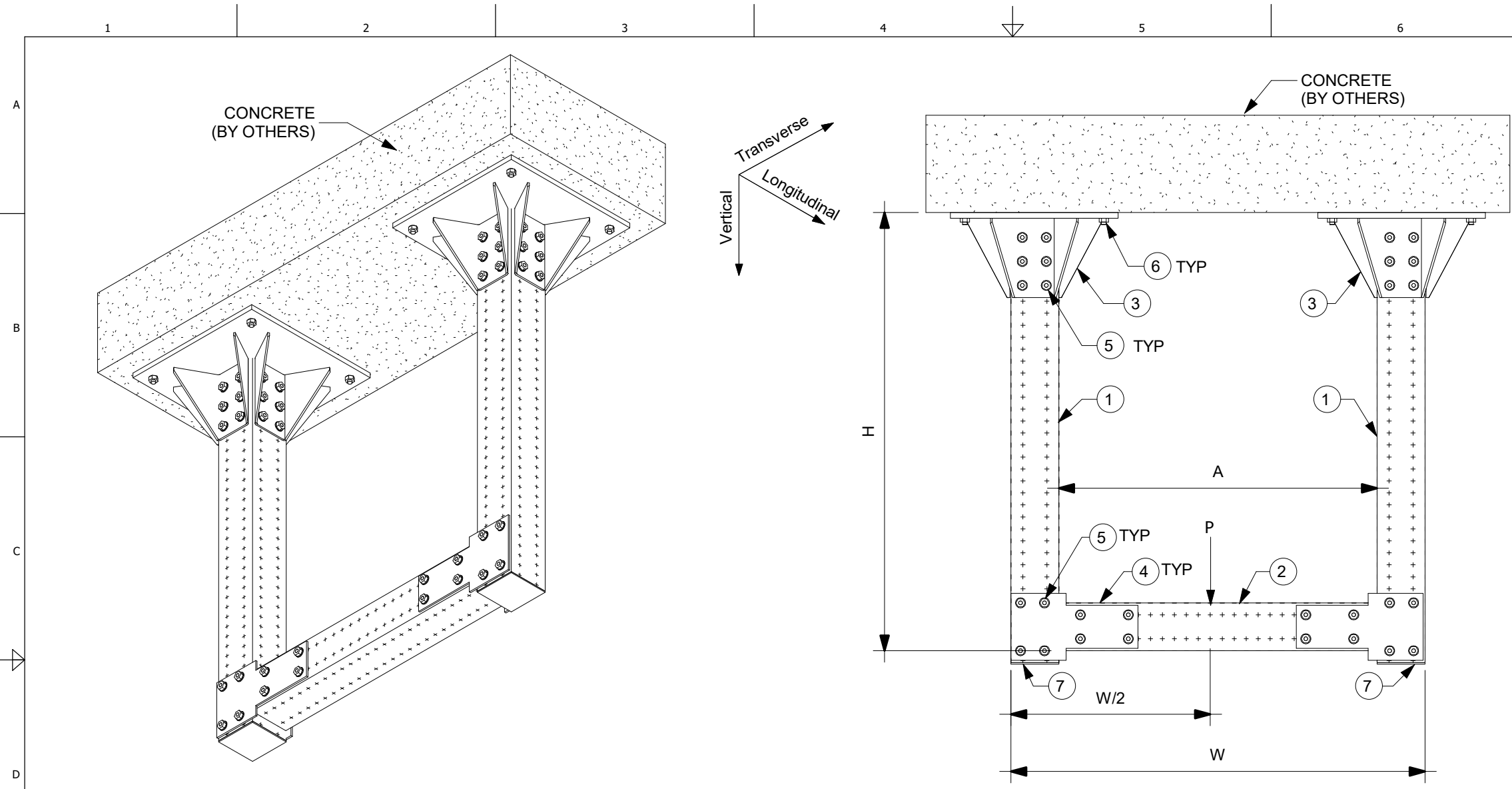

MARK	ITEM NO.	DESCRIPTION	QTY
1	2268369	MT-90 OC	2
2	2268369	MT-90 OC	1
3	2272103	MT-B-GL-O4 OC	2
4	2272075	MT-C-GLP T OC	4
5	2272084	MT-TFB OC	80
6	2210278	ANCHOR KB-TZ2 5/8" X 4-3/4" SS304	8
7	2273699	MT-EC-90	2

1 ISOMETRIC
N.T.S.

2 ELEVATION
N.T.S.

NOTE(S):

- A. THE TYPICAL SUPPORT IS LOAD RATED AND DIMENSIONALLY LIMITED BASED ON DESIGN METHODOLOGY AND GENERIC NON-PROJECT SPECIFIC ASSUMPTIONS SET FORTH IN PROFIS MODULAR SUPPORTS ENGINEERING SOFTWARE VERSION 1.3. THE ENGINEER OF RECORD SHALL EVALUATE THIS TYPICAL SUPPORT TO DETERMINE ITS SUITABILITY FOR THE ACTUAL PROJECT SPECIFIC DESIGN CRITERIA AND REQUIREMENTS.
- B. THE EVALUATION OF EXISTING STRUCTURE IS OUTSIDE OF THE TYPICAL DESIGN SCOPE AND SHALL BE PERFORMED BY THE ENGINEER OF RECORD.
- C. TYPICAL SUPPORT DESIGN IS BASED ON INTERNATIONAL BUILDING CODE (IBC) 2018. SEE TABLE-A FOR ALLOWABLE STRENGTH DESIGN LOADS (STATIC U.N.O.); GOVERNING LATERAL LOADS NOTED IN THE ALLOWABLE LOAD TABLE IS MAXIMUM OF 30% OF DEAD LOAD.
- D. ALL LOADS ASSUMED TO ACT ON THE SUPPORT, NO ECCENTRICITY CONSIDERED
- E. MAXIMUM ALLOWABLE LOADS NOTED IN TABLE-A ARE BASED ON THE GOVERNING COMBINATION OF VERTICAL LOAD WITH TRANSVERSE LOAD OR VERTICAL LOAD WITH LONGITUDINAL LOAD. A SEPARATE ANALYSIS MUST BE PERFORMED WHEN TRANSVERSE AND LONGITUDINAL LOAD OCCURS SIMULTANEOUSLY.
- F. REFER TO HILTI INSTRUCTION FOR USE SHEET FOR REQUIRED INSTALLATION INFORMATION. THREAD FORMING BOLD MAY BE INSTALLED USING A TORQUE WRENCH OR SI-AT-A22 PER INSTRUCTION FOR USE.
- G. SEE BOM FOR KWIK BOLT-TZ2 ANCHOR BOLT. FOR 1/2" DIA. HILTI KWIK BOLT-TZ2 USE MIN. 3-1/4" EFFECTIVE EMBEDMENT. FOR 5/8" DIA. KWIK BOLT-TZ2 USE 3-1/4" MIN. EFFECTIVE EMBEDMENT. INSTALL ANCHOR PER ESR-4266 AND HILTI'S INSTRUCTIONS FOR USE AND RECOMMENDATIONS. MIN. CONCRETE COMPRESSIVE STRENGTH $f'_c=3000$ PSI, MIN. CONCRETE EDGE DISTANCE = 6", AND MIN. CONCRETE THICKNESS = 6".
- H. CONCRETE ANCHORS NOTED IN THE BILL OF MATERIAL ARE DESIGNED ONLY FOR WIND LATERAL LOADING. ENGINEER OF RECORD TO VERIFY ADEQUACY OF ANCHOR WHEN TYPICAL IS BEING USED FOR SEISMIC LATERAL LOADING

	36	48	60
Max H, in	36	48	60
Max W, in	36	48	60
Max A, in	28-1/8	40-1/8	52-1/8
Vertical (P)	3000	2500	2200
Transverse	900	750	660
Longitudinal	900	750	660

ALLOWABLE LOADS, lbs

All loading and design criteria supplied by customer is assumed accurate. Only the stated Design Assumptions were considered, and must be verified by the responsible Engineer of Record (EOR). The basis of Hilti component and connection design is the published data in the current Hilti Technical Guide, including material and cross-section properties, allowable load values, factors of safety, methods of calculation, and limiting factors. The EOR must verify suitability for any specific application, and the capacity of the supportive structure to receive the shown configuration and associated reaction loads. Modification to components and/or design may alter performance and must be evaluated by the EOR.

REVISION HISTORY		
NO:	DESCRIPTION:	DATE:
B	ISSUE FOR REVIEW - UPDATED DIMENSIONS	03/03/2021
C	ISSUE FOR BU USE	07/06/2021
D	ANCHOR NOTE AND BOM MODIFICATION FOR ANCHOR	03/22/2022

PROJECT NAME: **TRAPEZE MT90 C 002**



PROJECT DESCRIPTION: **TRAPEZE MT90 C 002**

DRAWN:	CHECKED:	DESIGNED:	REVIEWED:
GAB	IDP	JDR	BVD
PAPER SIZE:	PROJECT NUMBER:		
ANSI B	PROJECT	JOB	SHEET
	- TR9C2 -		1

MARK	ITEM NO.	DESCRIPTION	QTY.
1	2268365	MT-70 OC	2
2	2268365	MT-70 OC	2
3	2272101	MT-B-GS O4U OC	2
4	2272073	MT-C-GSP L OC	8
5	2272084	MT-TFB OC	44
6	2273697	MT-EC-70	2
7	2210261	ANCHOR KB-TZ2 1/2" x 4-1/2" SS304	8

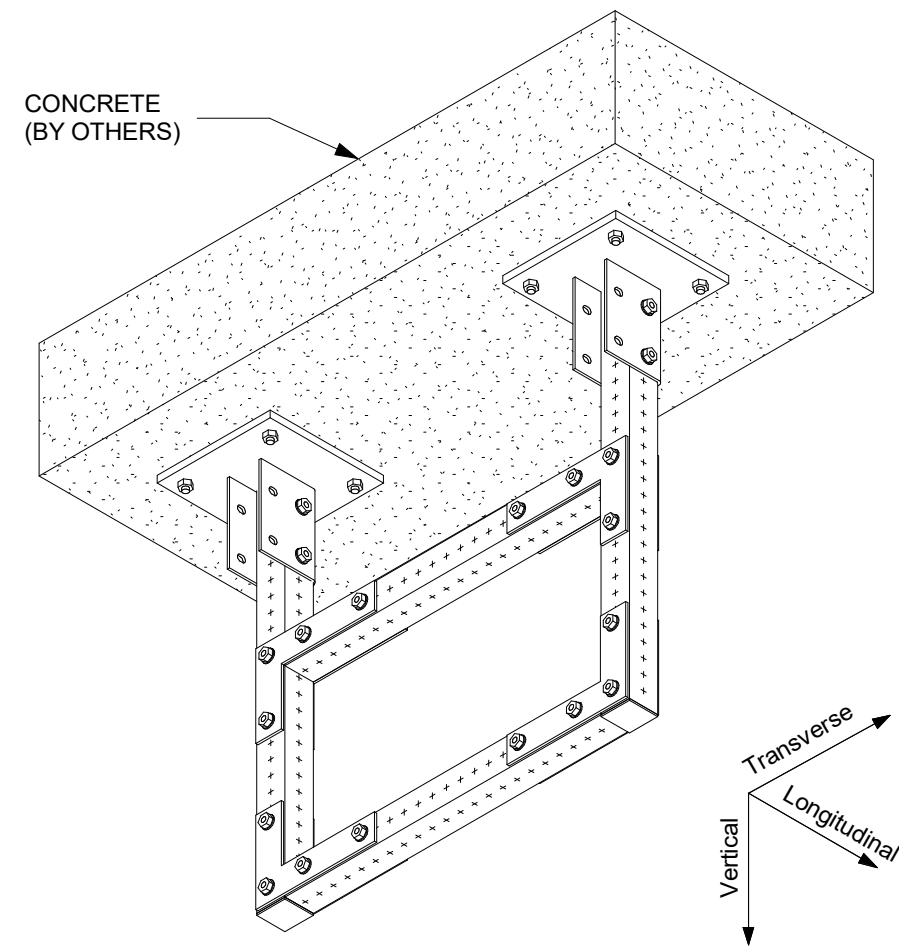

1 ISOMETRIC
N.T.S.

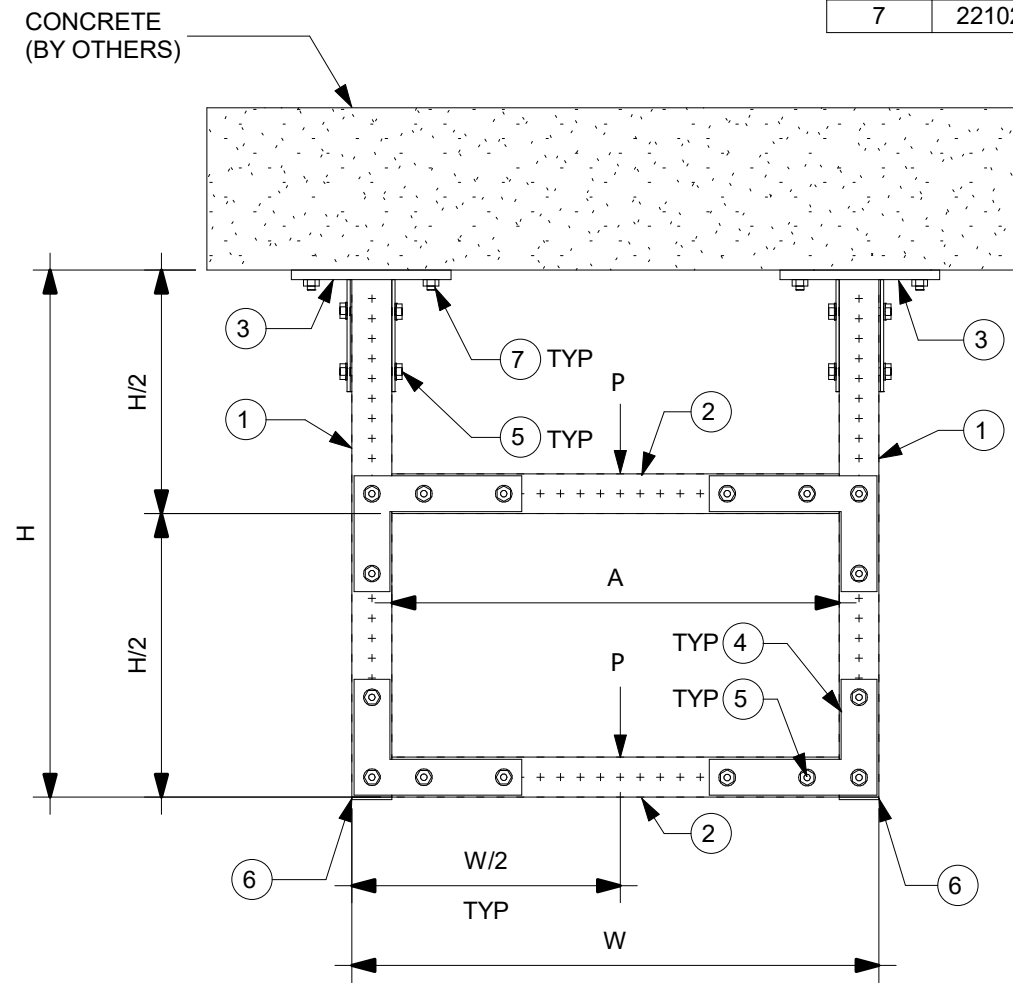

2 ELEVATION
N.T.S.

NOTE(S):

A. THE TYPICAL SUPPORT IS LOAD RATED AND DIMENSIONALLY LIMITED BASED ON DESIGN METHODOLOGY AND GENERIC NON-PROJECT SPECIFIC ASSUMPTIONS SET FORTH IN PROFIS MODULAR SUPPORTS ENGINEERING SOFTWARE VERSION 1.3. THE ENGINEER OF RECORD SHALL EVALUATE THIS TYPICAL SUPPORT TO DETERMINE ITS SUITABILITY FOR THE ACTUAL PROJECT SPECIFIC DESIGN CRITERIA AND REQUIREMENTS.

B. THE EVALUATION OF EXISTING STRUCTURE IS OUTSIDE OF THE TYPICAL DESIGN SCOPE AND SHALL BE PERFORMED BY THE ENGINEER OF RECORD.

C. TYPICAL SUPPORT DESIGN IS BASED ON INTERNATIONAL BUILDING CODE (IBC) 2018. SEE TABLE-A FOR ALLOWABLE STRENGTH DESIGN LOADS (STATIC U.N.O.); GOVERNING LATERAL LOADS NOTED IN THE ALLOWABLE LOAD TABLE IS MAXIMUM OF 30% OF DEAD LOAD.

D. ALL LOADS ASSUMED TO ACT ON THE SUPPORT, NO ECCENTRICITY CONSIDERED

E. MAXIMUM ALLOWABLE LOADS NOTED IN TABLE-A ARE BASED ON THE GOVERNING COMBINATION OF VERTICAL LOAD WITH TRANSVERSE LOAD OR VERTICAL LOAD WITH LONGITUDINAL LOAD. A SEPARATE ANALYSIS MUST BE PERFORMED WHEN TRANSVERSE AND LONGITUDINAL LOAD OCCURS SIMULTANEOUSLY.

F. REFER TO HILTI INSTRUCTION FOR USE SHEET FOR REQUIRED INSTALLATION INFORMATION.

G. SEE BOM FOR KWIK BOLT-TZ2 ANCHOR BOLT. FOR 1/2" DIA. HILTI KWIK BOLT-TZ2 USE MIN. 3-1/4" EFFECTIVE EMBEDMENT. FOR 5/8" DIA. KWIK BOLT-TZ2 USE 3-1/4" MIN. EFFECTIVE EMBEDMENT. INSTALL ANCHOR PER ESR-4266 AND HILTI'S INSTRUCTIONS FOR USE AND RECOMMENDATIONS. MIN. CONCRETE COMPRESSIVE STRENGTH $f'_c=3000$ PSI, MIN. CONCRETE EDGE DISTANCE = 6", AND MIN. CONCRETE THICKNESS = 6".

H. CONCRETE ANCHORS NOTED IN THE BILL OF MATERIAL ARE DESIGNED ONLY FOR WIND LATERAL LOADING. ENGINEER OF RECORD TO VERIFY ADEQUACY OF ANCHOR WHEN TYPICAL IS BEING USED FOR SEISMIC LATERAL LOADING.

	24	36	48
Max H, in	24	36	48
Max W, in	24	36	48
Max A, in	20-1/8	32-1/8	44-1/8
Vertical (P)	1400	850	475
Transverse	420	255	142
Longitudinal	420	255	142

ALLOWABLE LOADS, lbs

REVISION HISTORY		
NO.	DESCRIPTION:	DATE:
B	ISSUE FOR REVIEW - UPDATED DIMENSIONS	03/03/2021
C	ISSUE FOR BU USE	07/06/2021
D	ANCHOR NOTE AND BOM MODIFICATION FOR ANCHOR	03/22/2022

PROJECT NAME:
TRAPEZE MT70 C 003

PROJECT DESCRIPTION:
TRAPEZE MT70 C 003

HILTI

DRAWN:	CHECKED:	DESIGNED:	REVIEWED:
MDH	GAB	JDR	BVD
PAPER SIZE: ANSI B		PROJECT NUMBER: - TR7C3 - 1	

MARK	ITEM NO.	DESCRIPTION	QTY.
1	2268365	MT-70 OC	2
2	2268365	MT-70 OC	2
3	2272101	MT-B-GS O4U OC	2
4	2272073	MT-C-GSP L OC	8
5	2272084	MT-TFB OC	44
6	2273697	MT-EC-70	2
7	2194341	X-BT-MR W10/15 SN 8	8

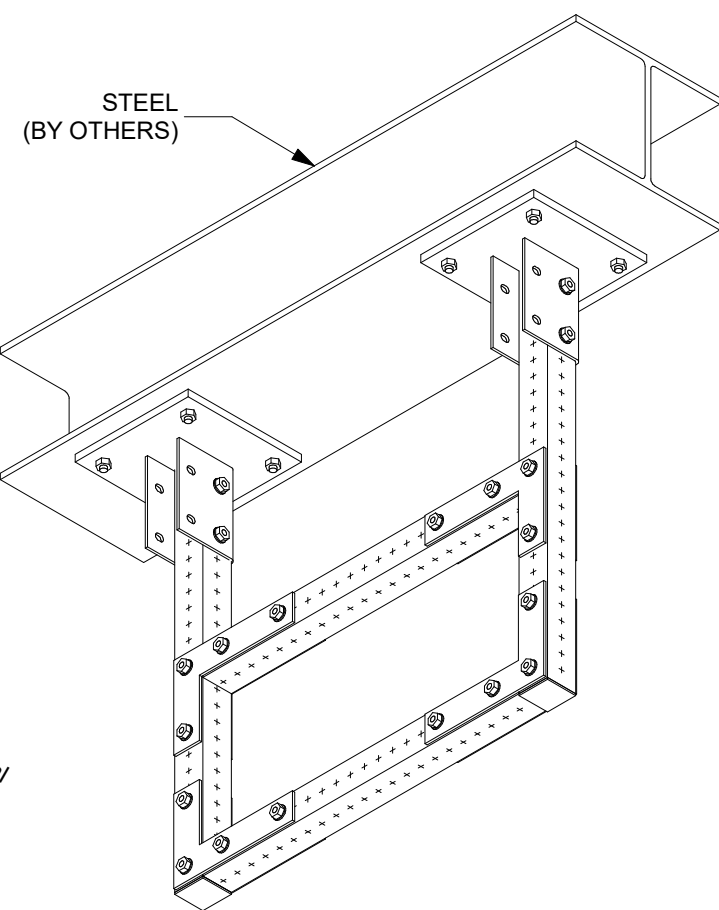

1 ISOMETRIC
N.T.S.

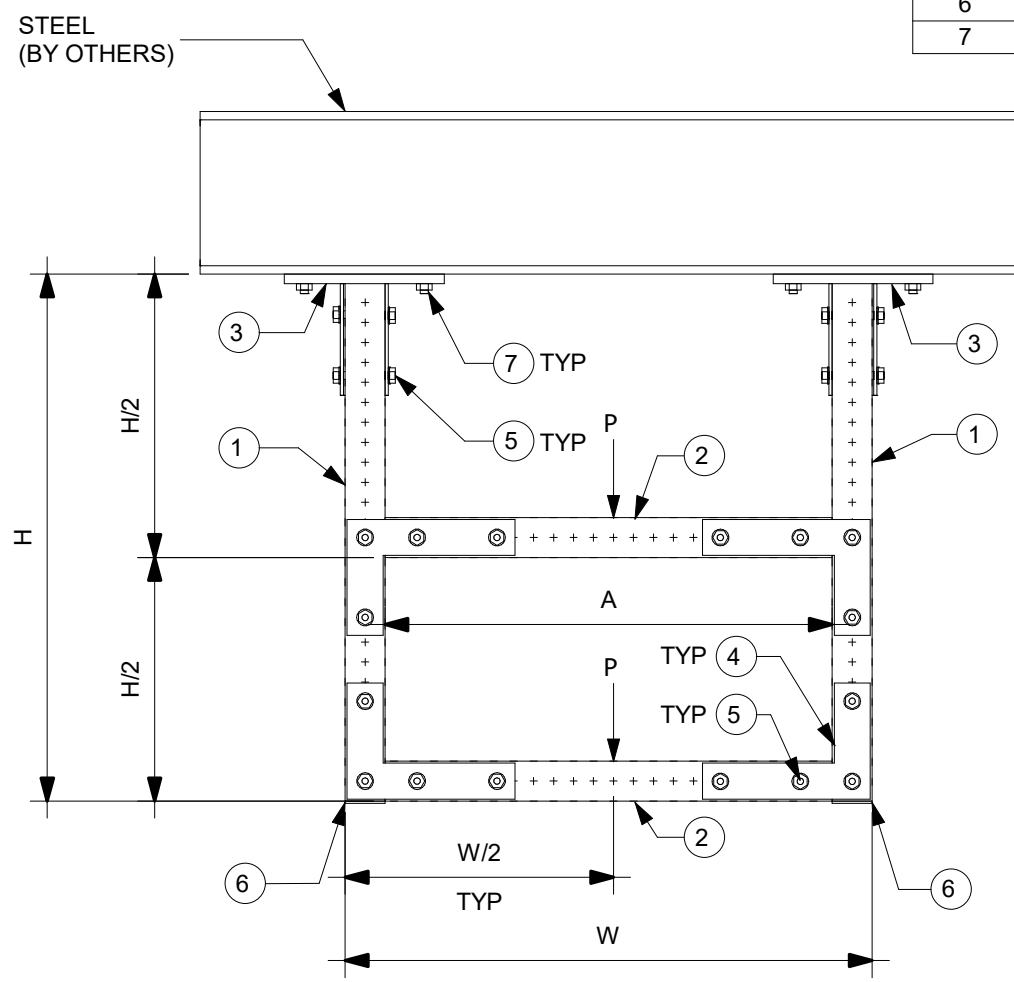

2 ELEVATION
N.T.S.

NOTE(S):

- A. THE TYPICAL SUPPORT IS LOAD RATED AND DIMENSIONALLY LIMITED BASED ON DESIGN METHODOLOGY AND GENERIC NON-PROJECT SPECIFIC ASSUMPTIONS SET FORTH IN PROFIS MODULAR SUPPORTS ENGINEERING SOFTWARE VERSION 1.3. THE ENGINEER OF RECORD SHALL EVALUATE THIS TYPICAL SUPPORT TO DETERMINE ITS SUITABILITY FOR THE ACTUAL PROJECT SPECIFIC DESIGN CRITERIA AND REQUIREMENTS.
- B. THE EVALUATION OF EXISTING STRUCTURE IS OUTSIDE OF THE TYPICAL DESIGN SCOPE AND SHALL BE PERFORMED BY THE ENGINEER OF RECORD.
- C. TYPICAL SUPPORT DESIGN IS BASED ON INTERNATIONAL BUILDING CODE (IBC) 2018. SEE TABLE-A FOR ALLOWABLE STRENGTH DESIGN LOADS (STATIC U.N.O.); GOVERNING LATERAL LOADS NOTED IN THE ALLOWABLE LOAD TABLE IS MAXIMUM OF 30% OF DEAD LOAD.
- D. ALL LOADS ASSUMED TO ACT ON THE SUPPORT, NO ECCENTRICITY CONSIDERED.
- E. MAXIMUM ALLOWABLE LOADS NOTED IN TABLE-A ARE BASED ON THE GOVERNING COMBINATION OF VERTICAL LOAD WITH TRANSVERSE LOAD OR VERTICAL LOAD WITH LONGITUDINAL LOAD. A SEPARATE ANALYSIS MUST BE PERFORMED WHEN TRANSVERSE AND LONGITUDINAL LOAD OCCURS SIMULTANEOUSLY.
- F. REFER TO HILTI INSTRUCTION FOR USE SHEET FOR REQUIRED INSTALLATION INFORMATION. THREAD FORMING BOLT MAY BE INSTALLED USING A TORQUE WRENCH OR SI-AT-A22 PER INSTRUCTION FOR USE.
- G. X-BT REQUIREMENT: MIN. STEEL BASE MATERIAL THICKNESS SHALL BE 5/16". MIN EDGE DISTANCE SHALL BE 3/8". MIN YIELD STRENGTH OF STEEL SHALL BE FY=36KSI.
- H. MINIMUM 8" FLANGE WIDTH REQUIRED.

	24	36	48
Max H, in	24	36	48
Max W, in	24	36	48
Max A, in	20-1/8	32-1/8	44-1/8
Vertical (P)	825	650	475
Transverse	248	195	142
Longitudinal	248	195	142

ALLOWABLE LOADS, lbs

All loading and design criteria supplied by customer is assumed accurate. Only the stated Design Assumptions were considered, and must be verified by the responsible Engineer of Record (EOR). The basis of Hilti component and connection design is the published data in the current Hilti Technical Guide, including material and cross-section properties, allowable load values, factors of safety, methods of calculation, and limiting factors. The EOR must verify suitability for any specific application, and the capacity of the supportive structure to receive the shown configuration and associated reaction loads. Modification to components and/or design may alter performance and must be evaluated by the EOR.

NO:	DESCRIPTION:	DATE:
A	ISSUE FOR REVIEW	08/19/2020
B	ISSUE FOR REVIEW	12/14/2020
C	ISSUE FOR REVIEW - NOTE MODIFICATIONS AND DIM CALLOUTS	05/28/2021

PROJECT NAME:
TRAPEZE MT70 S 003

PROJECT DESCRIPTION:
TRAPEZE MT70 S 003

DRAWN:	CHECKED:	DESIGNED:	REVIEWED:
MDH	GAB	JDR	BVD
PAPER SIZE:	PROJECT NUMBER:		
ANSI B	PROJECT	JOB	SHEET
	- TR7S3 -		1

MARK	ITEM NO.	DESCRIPTION	QTY.
1	2268367	MT-80 OC	2
2	2268367	MT-80 OC	2
3	2272101	MT-B-GS O4U OC	2
4	2272073	MT-C-GSP L OC	8
5	2272084	MT-TFB OC	52
6	2210261	ANCHOR KB-TZ2 1/2" x 4-1/2" SS304	8
7	2273698	MT-EC-80	2

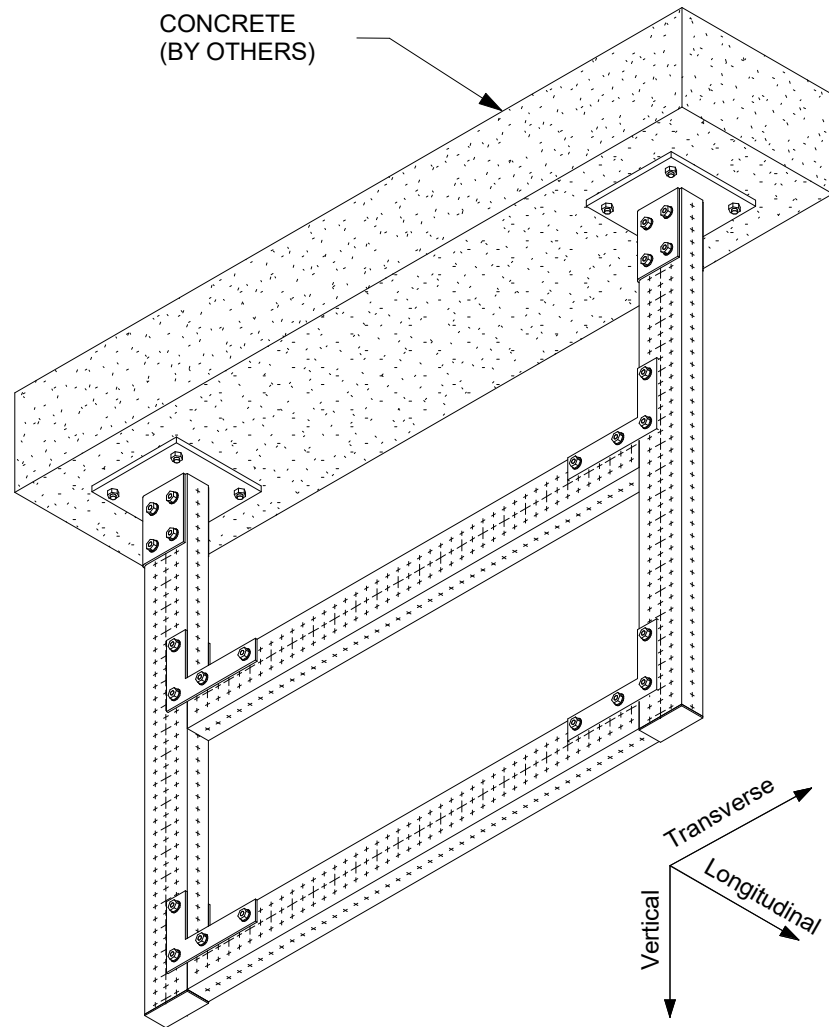

1 ISOMETRIC
N.T.S.

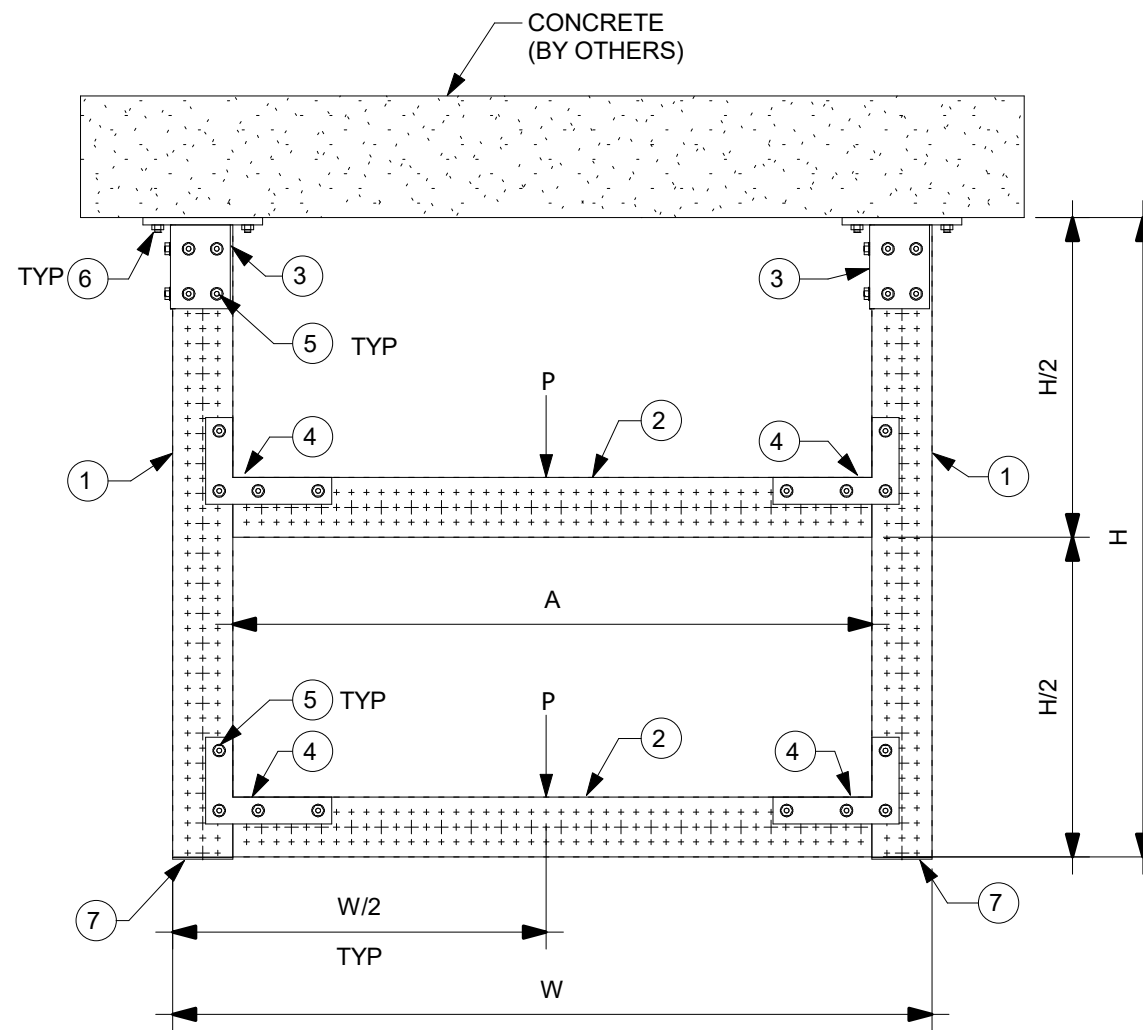

2 ELEVATION
N.T.S.

NOTE(S):

A. THE TYPICAL SUPPORT IS LOAD RATED AND DIMENSIONALLY LIMITED BASED ON DESIGN METHODOLOGY AND GENERIC NON-PROJECT SPECIFIC ASSUMPTIONS SET FORTH IN PROFIS MODULAR SUPPORTS ENGINEERING SOFTWARE VERSION 1.3. THE ENGINEER OF RECORD SHALL EVALUATE THIS TYPICAL SUPPORT TO DETERMINE ITS SUITABILITY FOR THE ACTUAL PROJECT SPECIFIC DESIGN CRITERIA AND REQUIREMENTS.

B. THE EVALUATION OF EXISTING STRUCTURE IS OUTSIDE OF THE TYPICAL DESIGN SCOPE AND SHALL BE PERFORMED BY THE ENGINEER OF RECORD.

C. TYPICAL SUPPORT DESIGN IS BASED ON INTERNATIONAL BUILDING CODE (IBC) 2018. SEE TABLE-A FOR ALLOWABLE STRENGTH DESIGN LOADS (STATIC U.N.O.); GOVERNING LATERAL LOADS NOTED IN THE ALLOWABLE LOAD TABLE IS MAXIMUM OF 30% OF DEAD LOAD.

D. ALL LOADS ASSUMED TO ACT ON THE SUPPORT, NO ECCENTRICITY CONSIDERED.

E. MAXIMUM ALLOWABLE LOADS NOTED IN TABLE-A ARE BASED ON THE GOVERNING COMBINATION OF VERTICAL LOAD WITH TRANSVERSE LOAD OR VERTICAL LOAD WITH LONGITUDINAL LOAD. A SEPARATE ANALYSIS MUST BE PERFORMED WHEN TRANSVERSE AND LONGITUDINAL LOAD OCCURS SIMULTANEOUSLY.

F. REFER TO HILTI INSTRUCTION FOR USE SHEET FOR REQUIRED INSTALLATION INFORMATION.

G. SEE BOM FOR KWIK BOLT-TZ2 ANCHOR BOLT. FOR 1/2" DIA. HILTI KWIK BOLT-TZ2 USE MIN. 3-1/4" EFFECTIVE EMBEDMENT. FOR 5/8" DIA. KWIK BOLT-TZ2 USE 3-1/4" MIN. EFFECTIVE EMBEDMENT. INSTALL ANCHOR PER ESR-4266 AND HILTI'S INSTRUCTIONS FOR USE AND RECOMMENDATIONS. MIN. CONCRETE COMPRESSIVE STRENGTH $f'_c=3000$ PSI, MIN. CONCRETE EDGE DISTANCE = 6", AND MIN. CONCRETE THICKNESS = 6".

H. CONCRETE ANCHORS NOTED IN THE BILL OF MATERIAL ARE DESIGNED ONLY FOR WIND LATERAL LOADING. ENGINEER OF RECORD TO VERIFY ADEQUACY OF ANCHOR WHEN TYPICAL IS BEING USED FOR SEISMIC LATERAL LOADING.

TABLE A				
Max H, in	24	36	48	
Max W, in	24	36	48	
Max A, in	16-1/8	28-1/8	40-1/8	
Vertical (P)	2000	1300	750	
Transverse	600	390	225	
Longitudinal	600	390	225	

ALLOWABLE
LOADS, lbs

All loading and design criteria supplied by customer is assumed accurate. Only the stated Design Assumptions were considered, and must be verified by the responsible Engineer of Record (EOR). The basis of Hilti component and connection design is the published data in the current Hilti Technical Guide, including material and cross-section properties, allowable load values, factors of safety, methods of calculation, and limiting factors. The EOR must verify suitability for any specific application, and the capacity of the supportive structure to receive the shown configuration and associated reaction loads. Modification to components and/or design may alter performance and must be evaluated by the EOR.

REVISION HISTORY

NO.	DESCRIPTION:	DATE:
B	ISSUE FOR REVIEW - UPDATED DIMENSIONS	03/03/2021
C	ISSUE FOR BU USE	07/06/2021
D	ANCHOR NOTE AND BOM MODIFICATION FOR ANCHOR	03/22/2022

PROJECT NAME:

TRAPEZE MT80 C 002

PROJECT DESCRIPTION:

TRAPEZE MT80 C 002

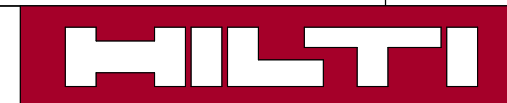

DRAWN: GAB CHECKED: IDP DESIGNED: JDR REVIEWED: BVD

PAPER SIZE: ANSI B PROJECT: GAB JOB: IDP SHEET: JDR BVD

PROJECT NUMBER: TR8C2 - 1

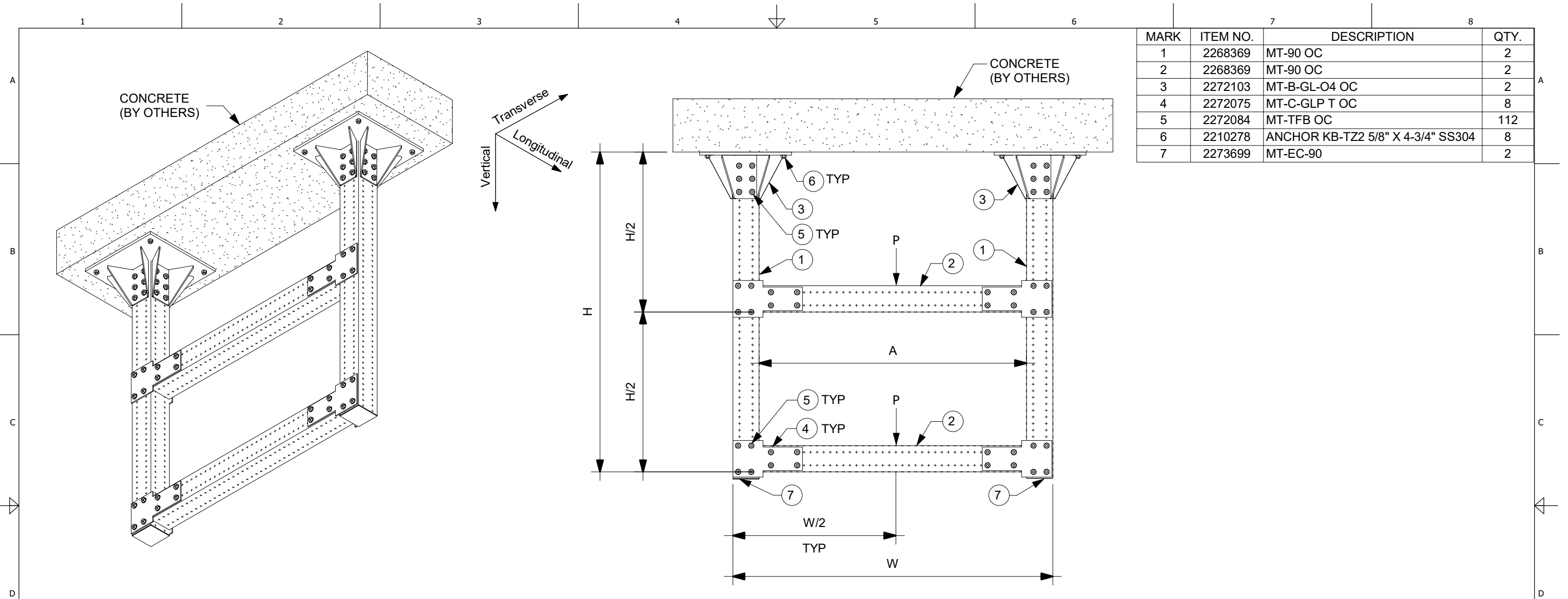

1 ISOMETRIC
N.T.S.

2 ELEVATION
N.T.S.

NOTE(S):

A. THE TYPICAL SUPPORT IS LOAD RATED AND DIMENSIONALLY LIMITED BASED ON DESIGN METHODOLOGY AND GENERIC NON-PROJECT SPECIFIC ASSUMPTIONS SET FORTH IN PROFIS MODULAR SUPPORTS ENGINEERING SOFTWARE VERSION 1.3. THE ENGINEER OF RECORD SHALL EVALUATE THIS TYPICAL SUPPORT TO DETERMINE ITS SUITABILITY FOR THE ACTUAL PROJECT SPECIFIC DESIGN CRITERIA AND REQUIREMENTS.

B. THE EVALUATION OF EXISTING STRUCTURE IS OUTSIDE OF THE TYPICAL DESIGN SCOPE AND SHALL BE PERFORMED BY THE ENGINEER OF RECORD.

C. TYPICAL SUPPORT DESIGN IS BASED ON INTERNATIONAL BUILDING CODE (IBC) 2018. SEE TABLE-A FOR ALLOWABLE STRENGTH DESIGN LOADS (STATIC U.N.O.); GOVERNING LATERAL LOADS NOTED IN THE ALLOWABLE LOAD TABLE IS MAXIMUM OF 30% OF DEAD LOAD.

D. ALL LOADS ASSUMED TO ACT ON THE SUPPORT, NO ECCENTRICITY CONSIDERED

E. MAXIMUM ALLOWABLE LOADS NOTED IN TABLE-A ARE BASED ON THE GOVERNING COMBINATION OF VERTICAL LOAD WITH TRANSVERSE LOAD OR VERTICAL LOAD WITH LONGITUDINAL LOAD. A SEPARATE ANALYSIS MUST BE PERFORMED WHEN TRANSVERSE AND LONGITUDINAL LOAD OCCURS SIMULTANEOUSLY.

F. REFER TO HILTI INSTRUCTION FOR USE SHEET FOR REQUIRED INSTALLATION INFORMATION. THREAD FORMING BOLD MAY BE INSTALLED USING A TORQUE WRENCH OR SI-AT-A22 PER INSTRUCTION FOR USE.

G. SEE BOM FOR KWIK BOLT-TZ2 ANCHOR BOLT. FOR 1/2" DIA. HILTI KWIK BOLT-TZ2 USE MIN. 3-1/4" EFFECTIVE EMBEDMENT. FOR 5/8" DIA. KWIK BOLT-TZ2 USE 3-1/4" MIN. EFFECTIVE EMBEDMENT. INSTALL ANCHOR PER ESR-4266 AND HILTI'S INSTRUCTIONS FOR USE AND RECOMMENDATIONS. MIN. CONCRETE COMPRESSIVE STRENGTH $f'_c=3000$ PSI, MIN. CONCRETE EDGE DISTANCE = 6", AND MIN. CONCRETE THICKNESS = 6".

H. CONCRETE ANCHORS NOTED IN THE BILL OF MATERIAL ARE DESIGNED ONLY FOR WIND LATERAL LOADING. ENGINEER OF RECORD TO VERIFY ADEQUACY OF ANCHOR WHEN TYPICAL IS BEING USED FOR SEISMIC LATERAL LOADING

TABLE A				
Max H, in	60	72	84	
Max W, in	60	72	84	
Max A, in	52-1/8	64-1/8	76-1/8	
Vertical (P)	1800	1550	1400	
Transverse	540	465	420	
Longitudinal	540	465	420	

ALLOWABLE LOADS, lbs

All loading and design criteria supplied by customer is assumed accurate. Only the stated Design Assumptions were considered, and must be verified by the responsible Engineer of Record (EOR). The basis of Hilti component and connection design is the published data in the current Hilti Technical Guide, including material and cross-section properties, allowable load values, factors of safety, methods of calculation, and limiting factors. The EOR must verify suitability for any specific application, and the capacity of the supportive structure to receive the shown configuration and associated reaction loads. Modification to components and/or design may alter performance and must be evaluated by the EOR.

REVISION HISTORY		
NO.	DESCRIPTION:	DATE:
B	NOTE MODIFICATIONS	01/29/2021
C	ISSUE FOR BU USE	07/06/2021
D	ANCHOR NOTE AND BOM MODIFICATION FOR ANCHOR	03/22/2022

PROJECT NAME: TRAPEZE MT90 C 003

PROJECT DESCRIPTION: TRAPEZE MT90 C 003

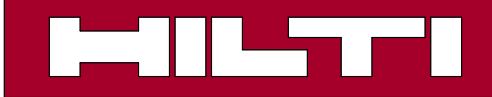
			
DRAWN:	CHECKED:	DESIGNED:	REVIEWED:
GAB	IDP	JDR	BVD
PAPER SIZE:	PROJECT NUMBER:		
ANSI B	PROJECT	JOB	SHEET
	- TR9C3 -		1

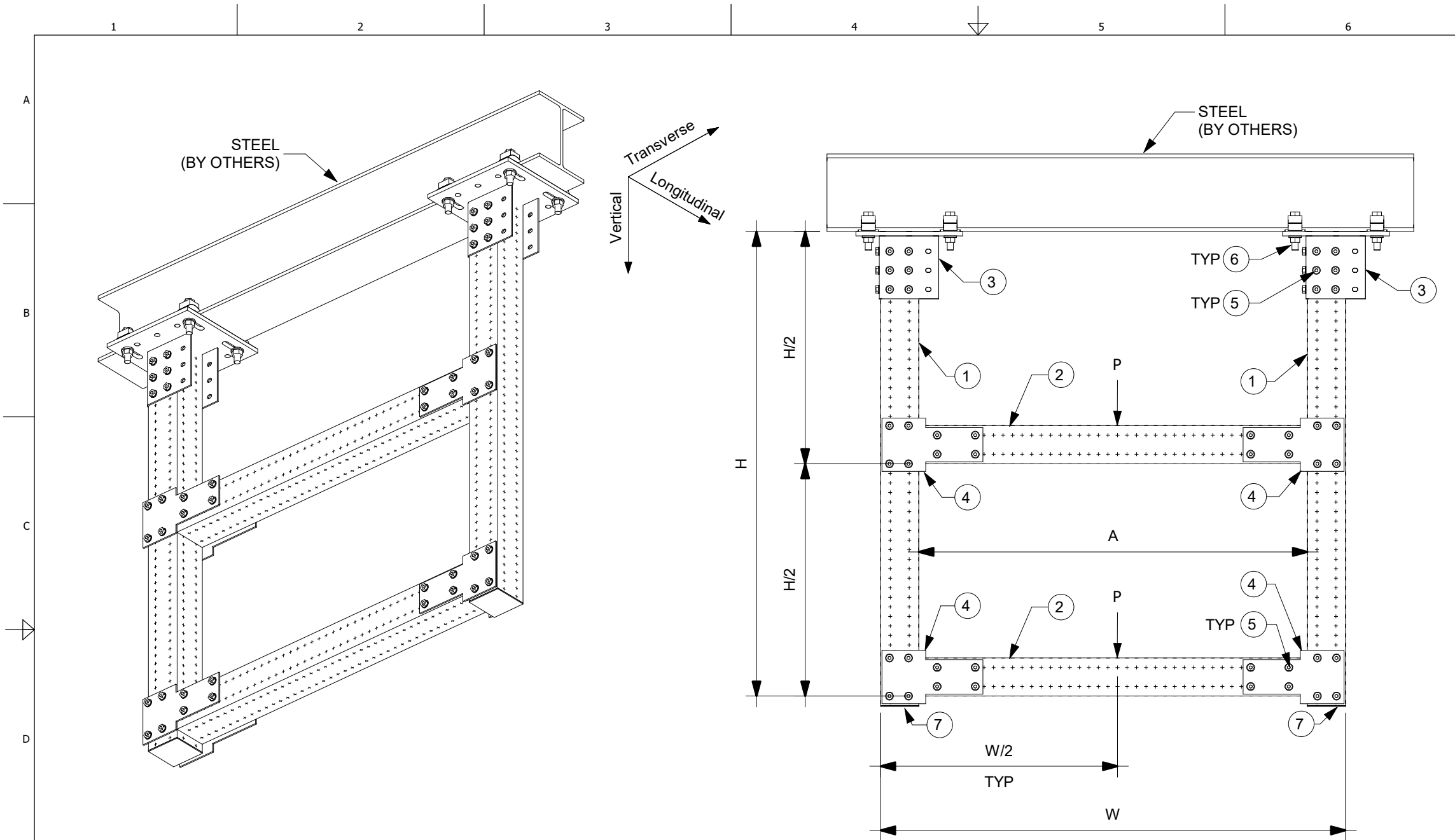

MARK	ITEM NO.	DESCRIPTION	QTY.
1	2268369	MT-90 OC	2
2	2268369	MT-90 OC	2
3	VARIABLES	MT-B-GXL S+ OC (SEE TABLE)	2
4	2272075	MT-C-GLP T OC	8
5	2272084	MT-TFB OC	100
6	387398	MI-SGC M16	8
7	2273699	MT-EC-90	2

MT-B-GXL S+ OC		
+	'B' Width	Item No.
1	2.9 to 6.5	2272106
2	6.5 to 9.2	2272107
3	9.2 to 11.8	2272108

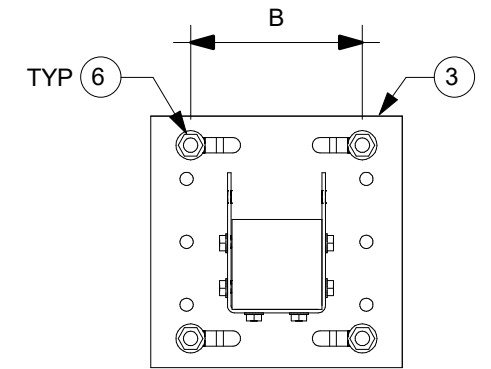

1 ISOMETRIC
N.T.S.

2 ELEVATION
N.T.S.

3 BASEPLATE DETAIL
N.T.S.

NOTE(S):

- A. THE TYPICAL SUPPORT IS LOAD RATED AND DIMENSIONALLY LIMITED BASED ON DESIGN METHODOLOGY AND GENERIC NON-PROJECT SPECIFIC ASSUMPTIONS SET FORTH IN PROFIS MODULAR SUPPORTS ENGINEERING SOFTWARE VERSION 1.3. THE ENGINEER OF RECORD SHALL EVALUATE THIS TYPICAL SUPPORT TO DETERMINE ITS SUITABILITY FOR THE ACTUAL PROJECT SPECIFIC DESIGN CRITERIA AND REQUIREMENTS.
- B. THE EVALUATION OF EXISTING STRUCTURE IS OUTSIDE OF THE TYPICAL DESIGN SCOPE AND SHALL BE PERFORMED BY THE ENGINEER OF RECORD.
- C. TYPICAL SUPPORT DESIGN IS BASED ON INTERNATIONAL BUILDING CODE (IBC) 2018. SEE TABLE-A FOR ALLOWABLE STRENGTH DESIGN LOADS (STATIC U.N.O.); GOVERNING LATERAL LOADS NOTED IN THE ALLOWABLE LOAD TABLE IS MAXIMUM OF 30% OF DEAD LOAD.
- D. ALL LOADS ASSUMED TO ACT ON THE SUPPORT, NO ECCENTRICITY CONSIDERED.
- E. MAXIMUM ALLOWABLE LOADS NOTED IN TABLE-A ARE BASED ON THE GOVERNING COMBINATION OF VERTICAL LOAD WITH TRANSVERSE LOAD OR VERTICAL LOAD WITH LONGITUDINAL LOAD. A SEPARATE ANALYSIS MUST BE PERFORMED WHEN TRANSVERSE AND LONGITUDINAL LOAD OCCURS SIMULTANEOUSLY.
- F. REFER TO HILTI INSTRUCTION FOR USE SHEET FOR REQUIRED INSTALLATION INFORMATION. THREAD FORMING BOLT MAY BE INSTALLED USING A TORQUE WRENCH OR SI-AT-A22 PER INSTRUCTION FOR USE.

TABLE A			
Max H, in	60	72	84
Max W, in	60	72	84
Max A, in	52-1/8	64-1/8	76-1/8
Vertical (P)	1500	1300	1100
Transverse	450	390	330
Longitudinal	450	390	330

ALLOWABLE LOADS, lbs

All loading and design criteria supplied by customer is assumed accurate. Only the stated Design Assumptions were considered, and must be verified by the responsible Engineer of Record (EOR). The basis of Hilti component and connection design is the published data in the current Hilti Technical Guide, including material and cross-section properties, allowable load values, factors of safety, methods of calculation, and limiting factors. The EOR must verify suitability for any specific application, and the capacity of the supportive structure to receive the shown configuration and associated reaction loads. Modification to components and/or design may alter performance and must be evaluated by the EOR.

REVISION HISTORY		
NO:	DESCRIPTION:	DATE:
A	ISSUE FOR REVIEW	12/18/2020
B	NOTE MODIFICATIONS	01/29/2021
C	ISSUE FOR REVIEW - NOTE MODIFICATIONS AND DIM CALLOUTS	05/28/2021

PROJECT NAME:
TRAPEZE MT90 S 003

PROJECT DESCRIPTION:
TRAPEZE MT90 S 003

DRAWN:	CHECKED:	DESIGNED:	REVIEWED:
GAB	IDP	JDR	BVD
PAPER SIZE:	PROJECT NUMBER:		
ANSI B	PROJECT	JOB	SHEET
	- TR9S3 -		1

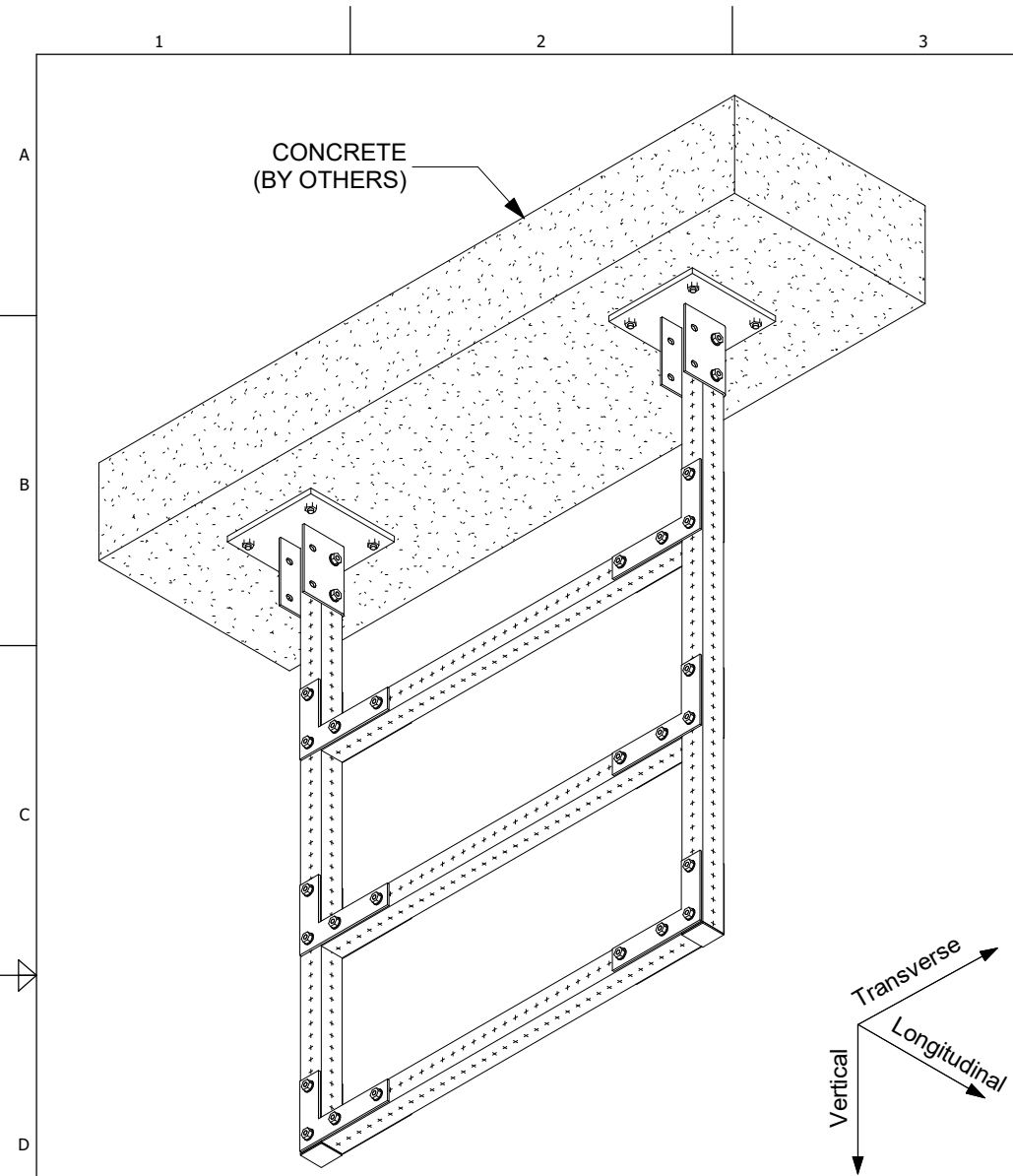

1 ISOMETRIC
N.T.S.

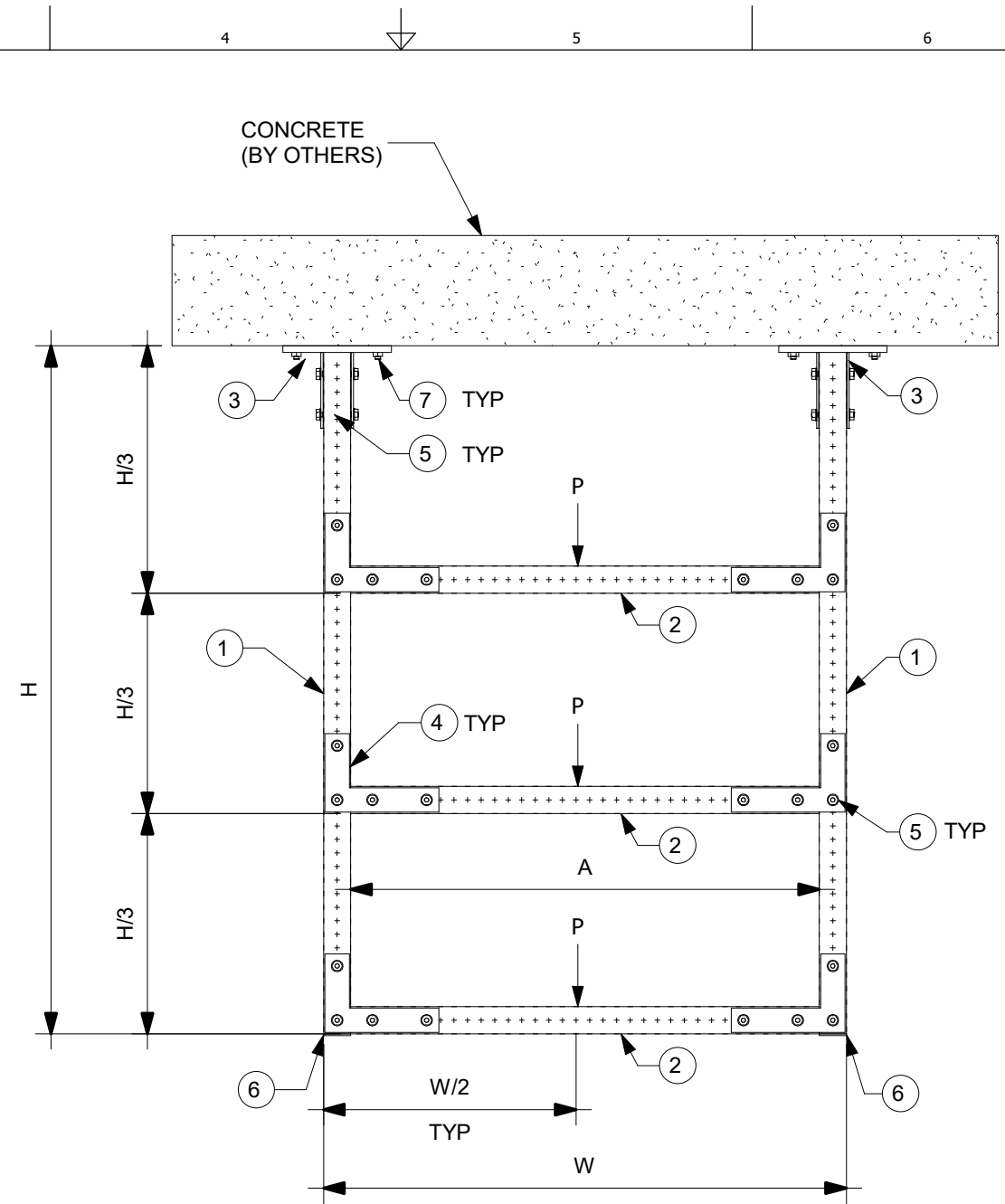

2 ELEVATION
N.T.S.

MARK	ITEM NO.	DESCRIPTION	QTY.
1	2268365	MT-70 OC	2
2	2268365	MT-70 OC	3
3	2272101	MT-B-GS O4U OC	2
4	2272073	MT-C-GSP L OC	12
5	2272084	MT-TFB OC	60
6	2273697	MT-EC-70	2
7	2210261	ANCHOR KB-TZ2 1/2" x 4-1/2" SS304	8

NOTE(S):

A. THE TYPICAL SUPPORT IS LOAD RATED AND DIMENSIONALLY LIMITED BASED ON DESIGN METHODOLOGY AND GENERIC NON-PROJECT SPECIFIC ASSUMPTIONS SET FORTH IN PROFIS MODULAR SUPPORTS ENGINEERING SOFTWARE VERSION 1.3. THE ENGINEER OF RECORD SHALL EVALUATE THIS TYPICAL SUPPORT TO DETERMINE ITS SUITABILITY FOR THE ACTUAL PROJECT SPECIFIC DESIGN CRITERIA AND REQUIREMENTS.

B. THE EVALUATION OF EXISTING STRUCTURE IS OUTSIDE OF THE TYPICAL DESIGN SCOPE AND SHALL BE PERFORMED BY THE ENGINEER OF RECORD.

C. TYPICAL SUPPORT DESIGN IS BASED ON INTERNATIONAL BUILDING CODE (IBC) 2018. SEE TABLE-A FOR ALLOWABLE STRENGTH DESIGN LOADS (STATIC U.N.O.); GOVERNING LATERAL LOADS NOTED IN THE ALLOWABLE LOAD TABLE IS MAXIMUM OF 30% OF DEAD LOAD.

D. ALL LOADS ASSUMED TO ACT ON THE SUPPORT, NO ECCENTRICITY CONSIDERED

E. MAXIMUM ALLOWABLE LOADS NOTED IN TABLE-A ARE BASED ON THE GOVERNING COMBINATION OF VERTICAL LOAD WITH TRANSVERSE LOAD OR VERTICAL LOAD WITH LONGITUDINAL LOAD. A SEPARATE ANALYSIS MUST BE PERFORMED WHEN TRANSVERSE AND LONGITUDINAL LOAD OCCURS SIMULTANEOUSLY.

F. REFER TO HILTI INSTRUCTION FOR USE SHEET FOR REQUIRED INSTALLATION INFORMATION.

G. SEE BOM FOR KWIK BOLT-TZ2 ANCHOR BOLT. FOR 1/2" DIA. HILTI KWIK BOLT-TZ2 USE MIN. 3-1/4" EFFECTIVE EMBEDMENT. FOR 5/8" DIA. KWIK BOLT-TZ2 USE 3-1/4" MIN. EFFECTIVE EMBEDMENT. INSTALL ANCHOR PER ESR-4266 AND HILTI'S INSTRUCTIONS FOR USE AND RECOMMENDATIONS. MIN. CONCRETE COMPRESSIVE STRENGTH F'C=3000 PSI, MIN. CONCRETE EDGE DISTANCE = 6", AND MIN. CONCRETE THICKNESS = 6".

H. CONCRETE ANCHORS NOTED IN THE BILL OF MATERIAL ARE DESIGNED ONLY FOR WIND LATERAL LOADING. ENGINEER OF RECORD TO VERIFY ADEQUACY OF ANCHOR WHEN TYPICAL IS BEING USED FOR SEISMIC LATERAL LOADING.

	36	48
Max H, in	36	48
Max W, in	36	48
Max A, in	32-1/8	44-1/8
Vertical (P)	650	375
Transverse	195	112
Longitudinal	195	112

ALLOWABLE LOADS, lbs

REVISION HISTORY	
NO.	DESCRIPTION:
B	ISSUE FOR REVIEW 12/14/2020
C	ISSUE FOR BU USE 07/06/2021
D	ANCHOR NOTE AND BOM MODIFICATION FOR ANCHOR 03/22/2022

PROJECT NAME: TRAPEZE MT70 C 004

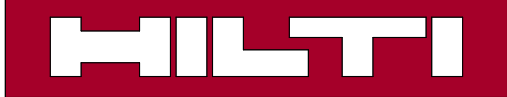

DRAWN:	CHECKED:	DESIGNED:	REVIEWED:
MDH	GAB	JDR	BVD

PAPER SIZE: ANSI B

PROJECT DESCRIPTION: TRAPEZE MT70 C 004

PROJECT NUMBER: TR7C4 - 1

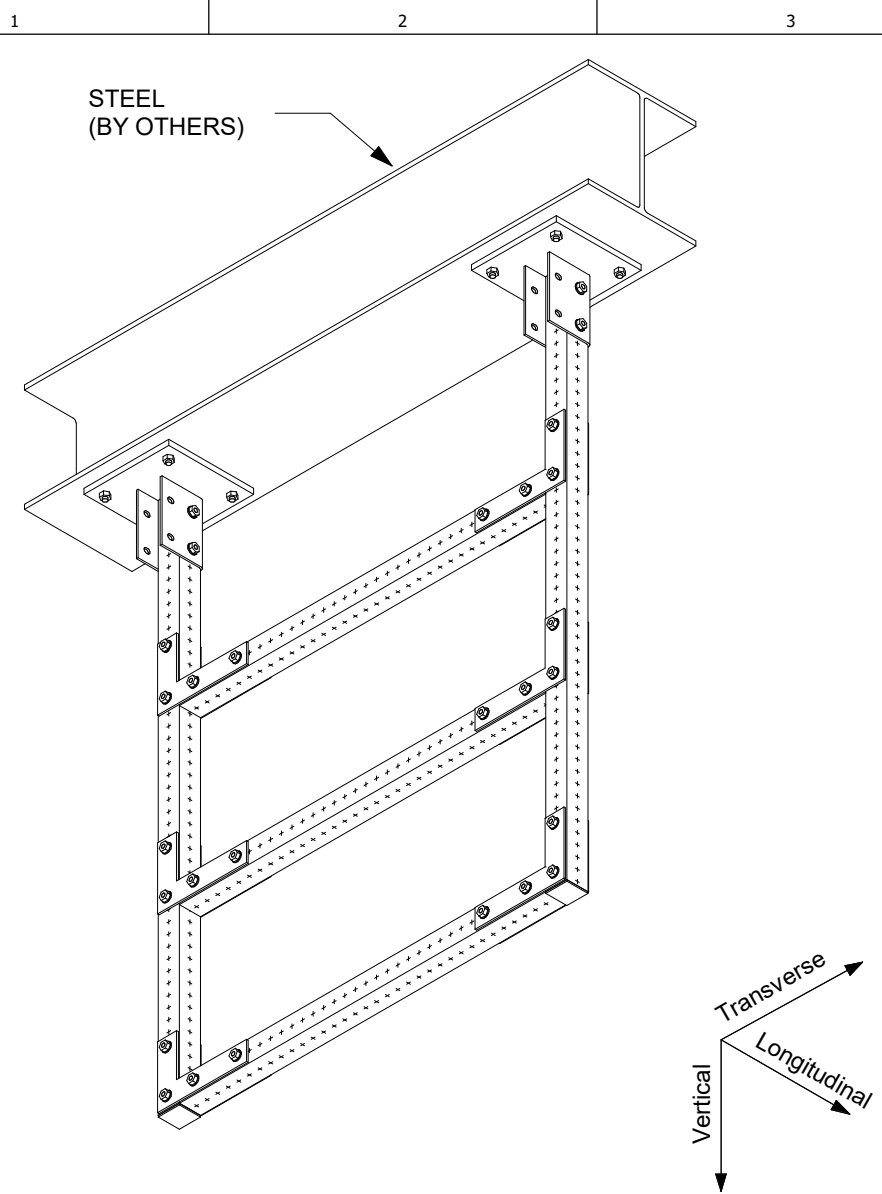

1 ISOMETRIC
N.T.S.

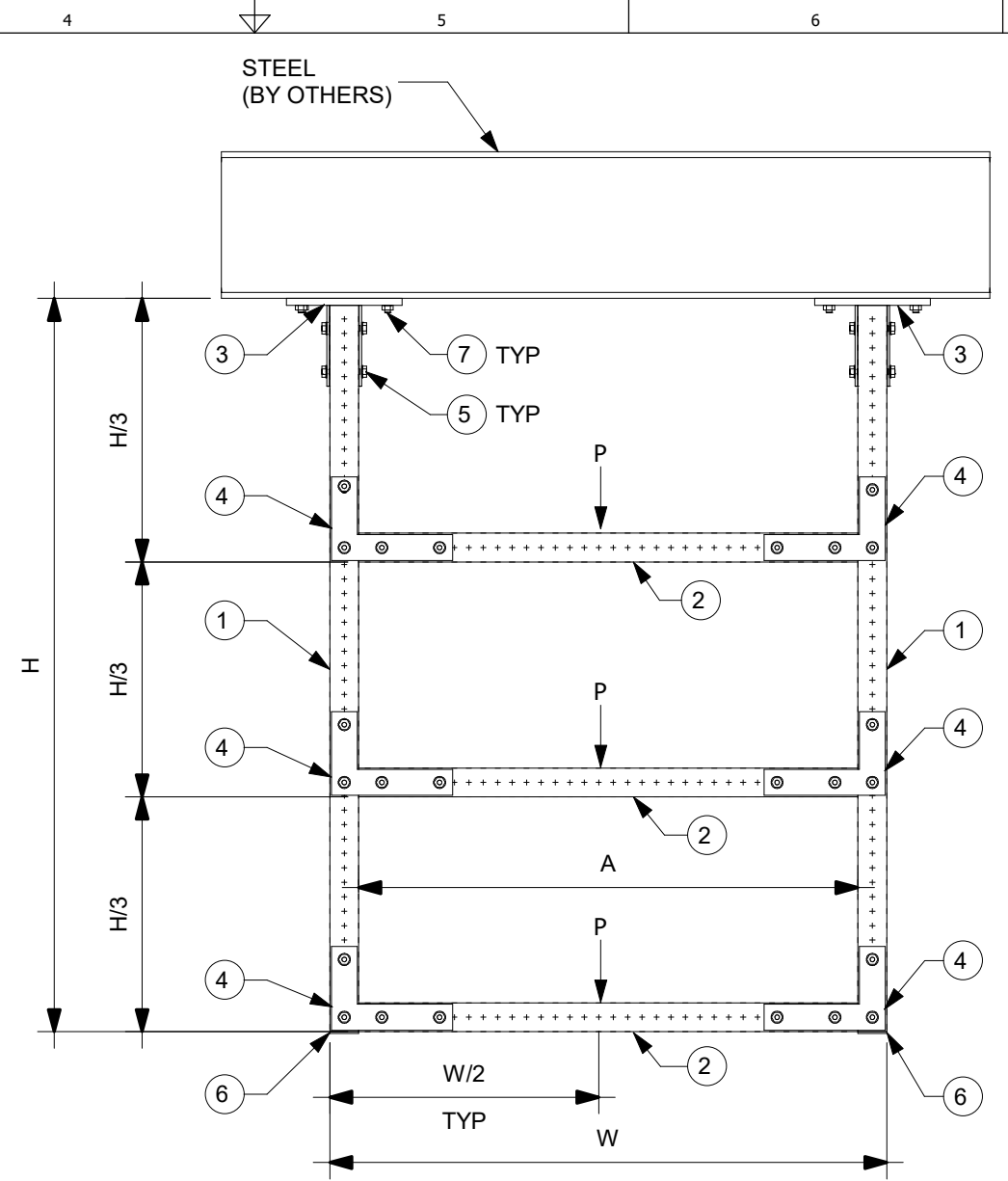

2 ELEVATION
N.T.S.

MARK	ITEM NO.	DESCRIPTION	QTY.
1	2268365	MT-70 OC	2
2	2268365	MT-70 OC	3
3	2272101	MT-B-GS O4U OC	2
4	2272073	MT-C-GSP L OC	12
5	2272084	MT-TFB OC	60
6	2273697	MT-EC-70	2
7	2194341	X-BT-MR W10/15 SN 8	8

NOTE(S):

A. THE TYPICAL SUPPORT IS LOAD RATED AND DIMENSIONALLY LIMITED BASED ON DESIGN METHODOLOGY AND GENERIC NON-PROJECT SPECIFIC ASSUMPTIONS SET FORTH IN PROFIS MODULAR SUPPORTS ENGINEERING SOFTWARE VERSION 1.5. THE ENGINEER OF RECORD SHALL EVALUATE THIS TYPICAL SUPPORT TO DETERMINE ITS SUITABILITY FOR THE ACTUAL PROJECT SPECIFIC DESIGN CRITERIA AND REQUIREMENTS.

B. THE EVALUATION OF EXISTING STRUCTURE IS OUTSIDE OF THE TYPICAL DESIGN SCOPE AND SHALL BE PERFORMED BY THE ENGINEER OF RECORD.

C. TYPICAL SUPPORT DESIGN IS BASED ON INTERNATIONAL BUILDING CODE (IBC) 2018. SEE TABLE-A FOR ALLOWABLE STRENGTH DESIGN LOADS (STATIC U.N.O.); GOVERNING LATERAL LOADS NOTED IN THE ALLOWABLE LOAD TABLE IS MAXIMUM OF 30% OF DEAD LOAD.

D. ALL LOADS ASSUMED TO ACT ON THE SUPPORT, NO ECCENTRICITY CONSIDERED.

E. MAXIMUM ALLOWABLE LOADS NOTED IN TABLE-A ARE BASED ON THE GOVERNING COMBINATION OF VERTICAL LOAD WITH TRANSVERSE LOAD OR VERTICAL LOAD WITH LONGITUDINAL LOAD. A SEPARATE ANALYSIS MUST BE PERFORMED WHEN TRANSVERSE AND LONGITUDINAL LOAD OCCURS SIMULTANEOUSLY.

F. REFER TO HILTI INSTRUCTION FOR USE SHEET FOR REQUIRED INSTALLATION INFORMATION. THREAD FORMING BOLT MAY BE INSTALLED USING A TORQUE WRENCH OR SI-AT-A22 PER INSTRUCTION FOR USE.

G. X-BT REQUIREMENT: MIN. STEEL BASE MATERIAL THICKNESS SHALL BE 5/16". MIN EDGE DISTANCE SHALL BE 3/8". MIN YIELD STRENGTH OF STEEL SHALL BE FY=36KSI.

H. MINIMUM 8" FLANGE WIDTH REQUIRED.

	24	36	48
Max H, in	24	36	48
Max W, in	24	36	48
Max A, in	20-1/8	32-1/8	44-1/8
Vertical (P)	725	550	375
Transverse	218	165	112
Longitudinal	218	165	112

ALLOWABLE LOADS, lbs

REVISION HISTORY			
NO:	DESCRIPTION:	DATE:	
A	ISSUE FOR REVIEW	08/19/2020	
B	ISSUE FOR REVIEW	12/14/2020	
C	ISSUE FOR REVIEW - NOTE MODIFICATIONS AND DIM CALLOUTS	05/28/2021	

PROJECT NAME: TRAPEZE MT70 S 004

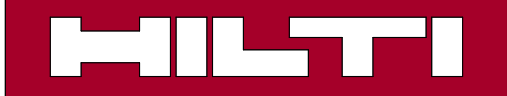

DRAWN:	CHECKED:	DESIGNED:	REVIEWED:
GAB	IDP	JDR	BVD

PROJECT DESCRIPTION: TRAPEZE MT70 S 004

PAPER SIZE:	PROJECT NUMBER:		
ANSI B	PROJECT	JOB	SHEET
	- TR7S4 -		1

MARK	ITEM NO.	DESCRIPTION	QTY.
1	2268367	MT-80 OC	2
2	2268367	MT-80 OC	3
3	2272101	MT-B-GS O4U OC	2
4	2272073	MT-C-GSP L OC	12
5	2272084	MT-TFB OC	68
6	2210261	ANCHOR KB-TZ2 1/2" x 4-1/2" SS304	8
7	2273698	MT-EC-80	2

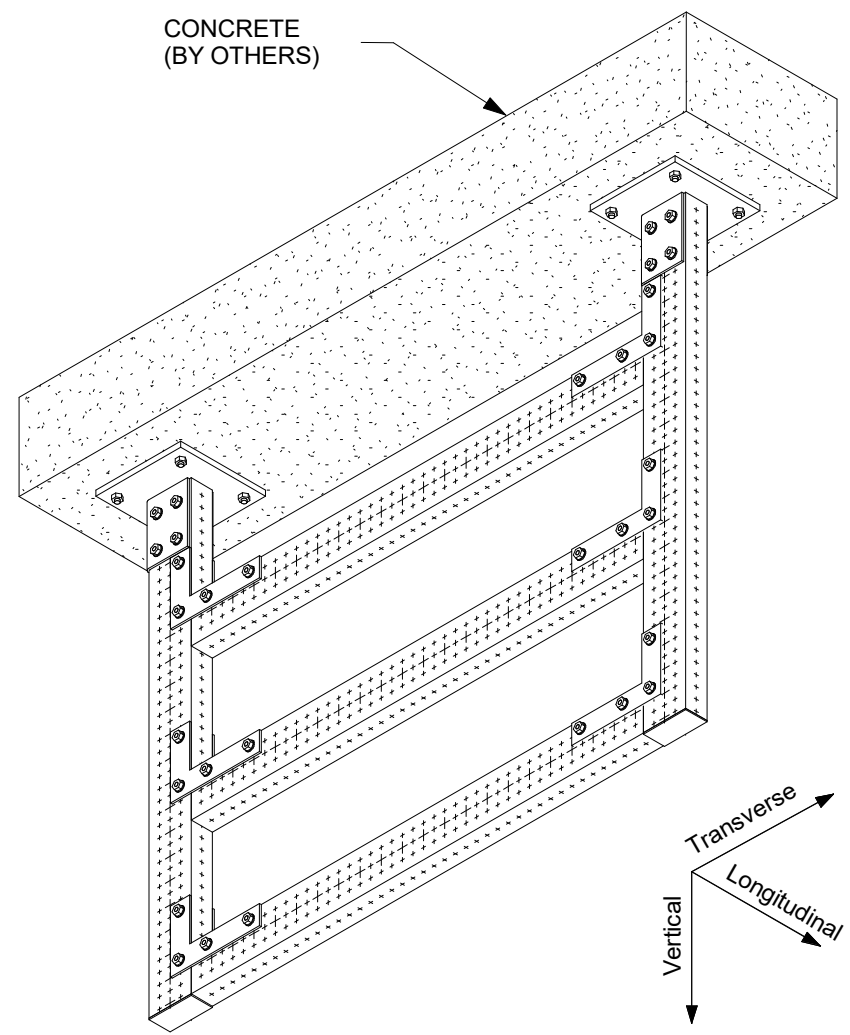

1 ISOMETRIC
N.T.S.

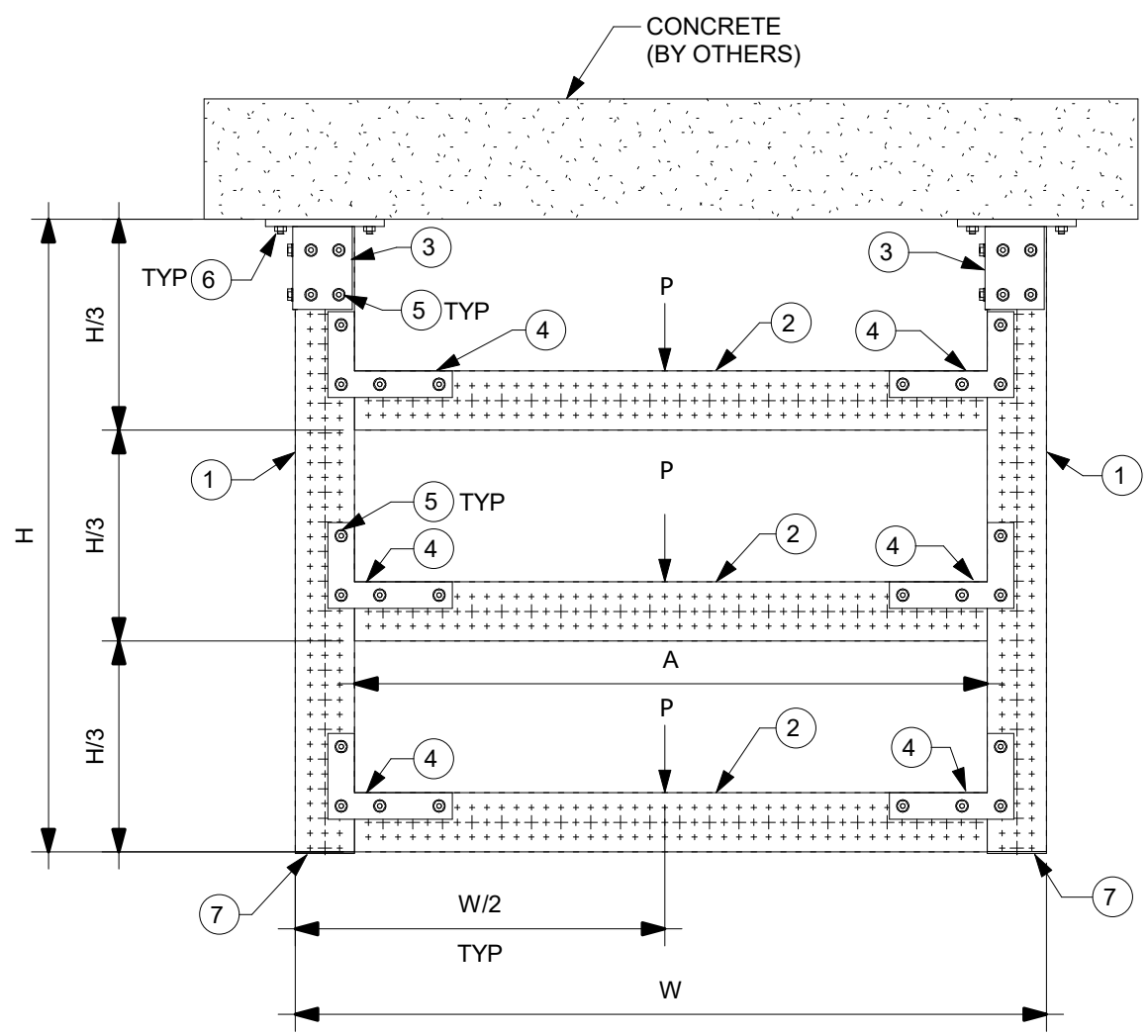

2 ELEVATION
N.T.S.

NOTE(S):

A. THE TYPICAL SUPPORT IS LOAD RATED AND DIMENSIONALLY LIMITED BASED ON DESIGN METHODOLOGY AND GENERIC NON-PROJECT SPECIFIC ASSUMPTIONS SET FORTH IN PROFIS MODULAR SUPPORTS ENGINEERING SOFTWARE VERSION 1.3. THE ENGINEER OF RECORD SHALL EVALUATE THIS TYPICAL SUPPORT TO DETERMINE ITS SUITABILITY FOR THE ACTUAL PROJECT SPECIFIC DESIGN CRITERIA AND REQUIREMENTS.

B. THE EVALUATION OF EXISTING STRUCTURE IS OUTSIDE OF THE TYPICAL DESIGN SCOPE AND SHALL BE PERFORMED BY THE ENGINEER OF RECORD.

C. TYPICAL SUPPORT DESIGN IS BASED ON INTERNATIONAL BUILDING CODE (IBC) 2018. SEE TABLE-A FOR ALLOWABLE STRENGTH DESIGN LOADS (STATIC U.N.O.); GOVERNING LATERAL LOADS NOTED IN THE ALLOWABLE LOAD TABLE IS MAXIMUM OF 30% OF DEAD LOAD.

D. ALL LOADS ASSUMED TO ACT ON THE SUPPORT, NO ECCENTRICITY CONSIDERED

E. MAXIMUM ALLOWABLE LOADS NOTED IN TABLE-A ARE BASED ON THE GOVERNING COMBINATION OF VERTICAL LOAD WITH TRANSVERSE LOAD OR VERTICAL LOAD WITH LONGITUDINAL LOAD. A SEPARATE ANALYSIS MUST BE PERFORMED WHEN TRANSVERSE AND LONGITUDINAL LOAD OCCURS SIMULTANEOUSLY.

F. REFER TO HILTI INSTRUCTION FOR USE SHEET FOR REQUIRED INSTALLATION INFORMATION.

G. SEE BOM FOR KWIK BOLT-TZ2 ANCHOR BOLT. FOR 1/2" DIA. HILTI KWIK BOLT-TZ2 USE MIN. 3-1/4" EFFECTIVE EMBEDMENT. FOR 5/8" DIA. KWIK BOLT-TZ2 USE 3-1/4" MIN. EFFECTIVE EMBEDMENT. INSTALL ANCHOR PER ESR-4266 AND HILTI'S INSTRUCTIONS FOR USE AND RECOMMENDATIONS. MIN. CONCRETE COMPRESSIVE STRENGTH $f'_c=3000$ PSI, MIN. CONCRETE EDGE DISTANCE = 6", AND MIN. CONCRETE THICKNESS = 6"

H. CONCRETE ANCHORS NOTED IN THE BILL OF MATERIAL ARE DESIGNED ONLY FOR WIND LATERAL LOADING. ENGINEER OF RECORD TO VERIFY ADEQUACY OF ANCHOR WHEN TYPICAL IS BEING USED FOR SEISMIC LATERAL LOADING.

	36	48
Max H, in	36	48
Max W, in	36	48
Max A, in	28-1/8	40-1/8
Vertical (P)	1000	575
Transverse	300	173
Longitudinal	300	173

ALLOWABLE LOADS, lbs

REVISION HISTORY		
NO.	DESCRIPTION:	DATE:
B	ISSUE FOR REVIEW - UPDATED DIMENSIONS	03/03/2021
C	ISSUE FOR BU USE	07/06/2021
D	ANCHOR NOTE AND BOM MODIFICATION FOR ANCHOR	03/22/2022

PROJECT NAME: TRAPEZE MT80 C 003

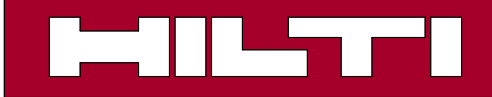

PROJECT DESCRIPTION: TRAPEZE MT80 C 003

DRAWN:	CHECKED:	DESIGNED:	REVIEWED:
GAB	IDP	JDR	BVD
PAPER SIZE: ANSI B		PROJECT NUMBER: TR8C3 - 1	

MARK	ITEM NO.	DESCRIPTION	QTY.
1	2268365	MT-70 OC	1
2	2268365	MT-70 OC	1
3	2272101	MT-B-GS O4U OC	1
4	2272073	MT-C-GSP L OC	2
5	2272084	MT-TFB OC	14
6	2210261	ANCHOR KB-TZ2 1/2" x 4-1/2" SS304	4
7	2273697	MT-EC-70	2

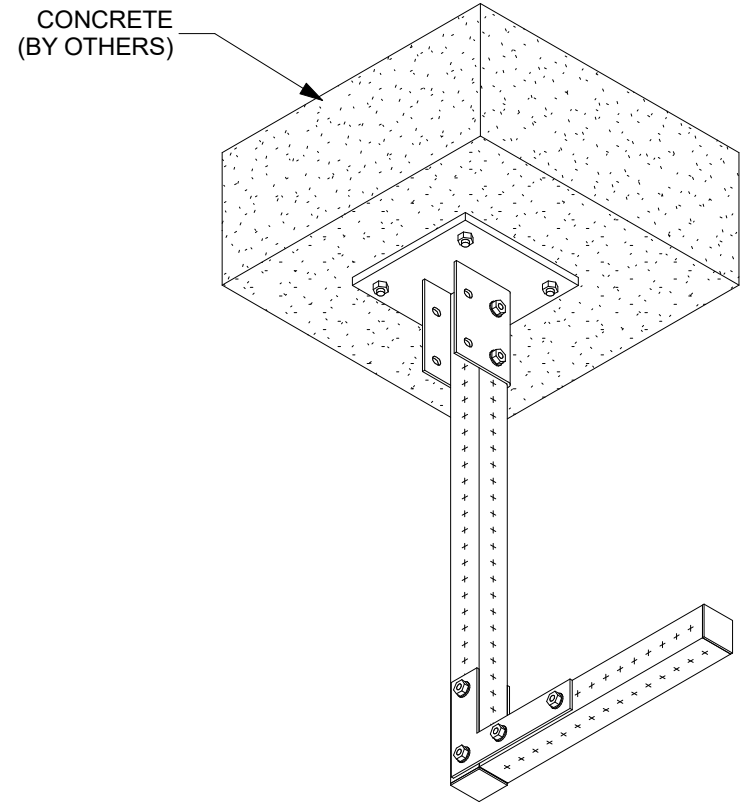

1 ISOMETRIC
N.T.S.

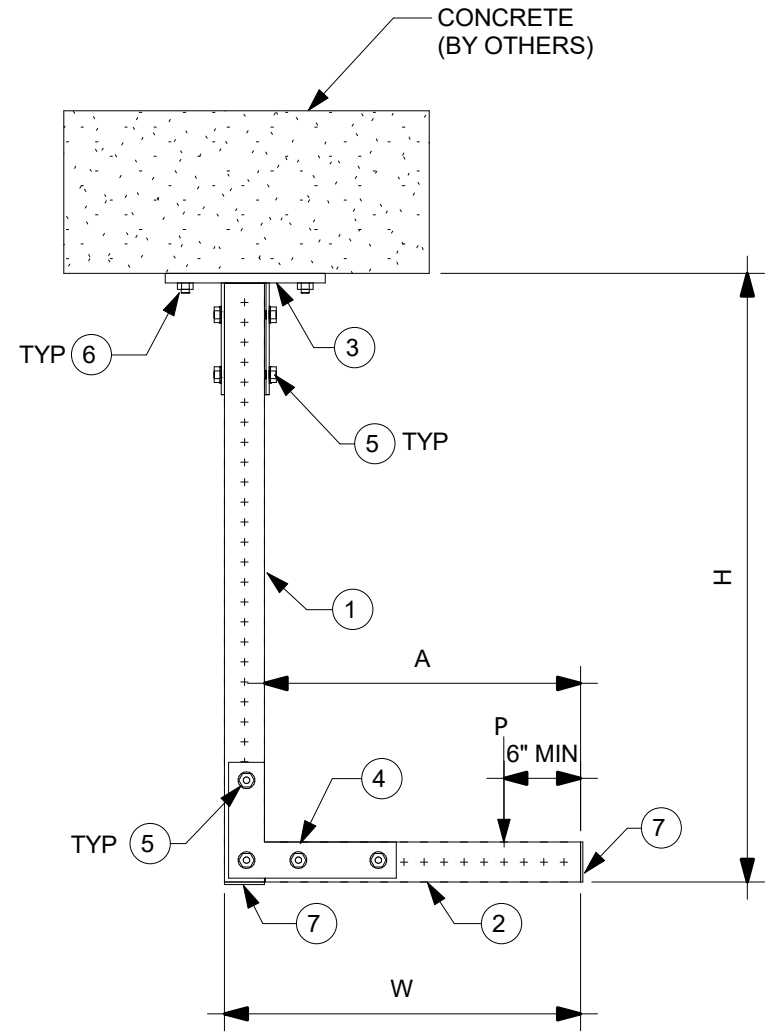

2 ELEVATION
N.T.S.

NOTE(S):

A. THE TYPICAL SUPPORT IS LOAD RATED AND DIMENSIONALLY LIMITED BASED ON DESIGN METHODOLOGY AND GENERIC NON-PROJECT SPECIFIC ASSUMPTIONS SET FORTH IN PROFIS MODULAR SUPPORTS ENGINEERING SOFTWARE VERSION 1.3. THE ENGINEER OF RECORD SHALL EVALUATE THIS TYPICAL SUPPORT TO DETERMINE ITS SUITABILITY FOR THE ACTUAL PROJECT SPECIFIC DESIGN CRITERIA AND REQUIREMENTS.

B. THE EVALUATION OF EXISTING STRUCTURE IS OUTSIDE OF THE TYPICAL DESIGN SCOPE AND SHALL BE PERFORMED BY THE ENGINEER OF RECORD.

C. TYPICAL SUPPORT DESIGN IS BASED ON INTERNATIONAL BUILDING CODE (IBC) 2018. SEE TABLE-A FOR ALLOWABLE STRENGTH DESIGN LOADS (STATIC U.N.O.); GOVERNING LATERAL LOADS NOTED IN THE ALLOWABLE LOAD TABLE IS MAXIMUM OF 30% OF DEAD LOAD.

D. ALL LOADS ASSUMED TO ACT ON THE SUPPORT, NO ECCENTRICITY CONSIDERED

E. MAXIMUM ALLOWABLE LOADS NOTED IN TABLE-A ARE BASED ON THE GOVERNING COMBINATION OF VERTICAL LOAD WITH TRANSVERSE LOAD OR VERTICAL LOAD WITH LONGITUDINAL LOAD. A SEPARATE ANALYSIS MUST BE PERFORMED WHEN TRANSVERSE AND LONGITUDINAL LOAD OCCURS SIMULTANEOUSLY.

F. REFER TO HILTI INSTRUCTION FOR USE SHEET FOR REQUIRED INSTALLATION INFORMATION. THREAD FORMING BOLT MAY BE INSTALLED USING A TORQUE WRENCH OR SI-AT-A22 PER INSTRUCTION FOR USE.

G. SEE BOM FOR KWIK BOLT-TZ2 ANCHOR BOLT. FOR 1/2" DIA. HILTI KWIK BOLT-TZ2 USE MIN. 3-1/4" EFFECTIVE EMBEDMENT. FOR 5/8" DIA. KWIK BOLT-TZ2 USE 3-1/4" MIN. EFFECTIVE EMBEDMENT. INSTALL ANCHOR PER ESR-4266 AND HILTI'S INSTRUCTIONS FOR USE AND RECOMMENDATIONS. MIN. CONCRETE COMPRESSIVE STRENGTH F'C=3000 PSI, MIN. CONCRETE EDGE DISTANCE = 6", AND MIN. CONCRETE THICKNESS = 6".

H. CONCRETE ANCHORS NOTED IN THE BILL OF MATERIAL ARE DESIGNED ONLY FOR WIND LATERAL LOADING. ENGINEER OF RECORD TO VERIFY ADEQUACY OF ANCHOR WHEN TYPICAL IS BEING USED FOR SEISMIC LATERAL LOADING.

	24	36
Max H, in	24	36
Max W, in	12	18
Max A, in	10-1/16	16-1/16
Vertical (P)	400	150
Transverse	120	45
Longitudinal	120	45

ALLOWABLE LOADS, lbs

REVISION HISTORY		
NO.	DESCRIPTION:	DATE:
B	ISSUE FOR REVIEW	12/14/2020
C	ISSUE FOR BU USE	07/06/2021
D	ANCHOR NOTE AND BOM MODIFICATION FOR ANCHOR	03/22/2022

PROJECT NAME:
L FRAME MT70 C 001

PROJECT DESCRIPTION:
L FRAME MT70 C 001

HILTI

DRAWN:	CHECKED:	DESIGNED:	REVIEWED:
GAB	IDP	JDR	BVD
PAPER SIZE:	PROJECT NUMBER:		
ANSI B	PROJECT	JOB	SHEET
	- LF7C1 -		1

1 2 3 4 5 6 7 8

MARK	ITEM NO.	DESCRIPTION	QTY.
1	2268365	MT-70 OC	1
2	2268365	MT-70 OC	1
3	2272101	MT-B-GS O4U OC	1
4	2272073	MT-C-GSP L OC	2
5	2272084	MT-TFB OC	14
6	2194341	X-BT-MR W10/15 SN 8	4
7	2273697	MT-EC-70	2

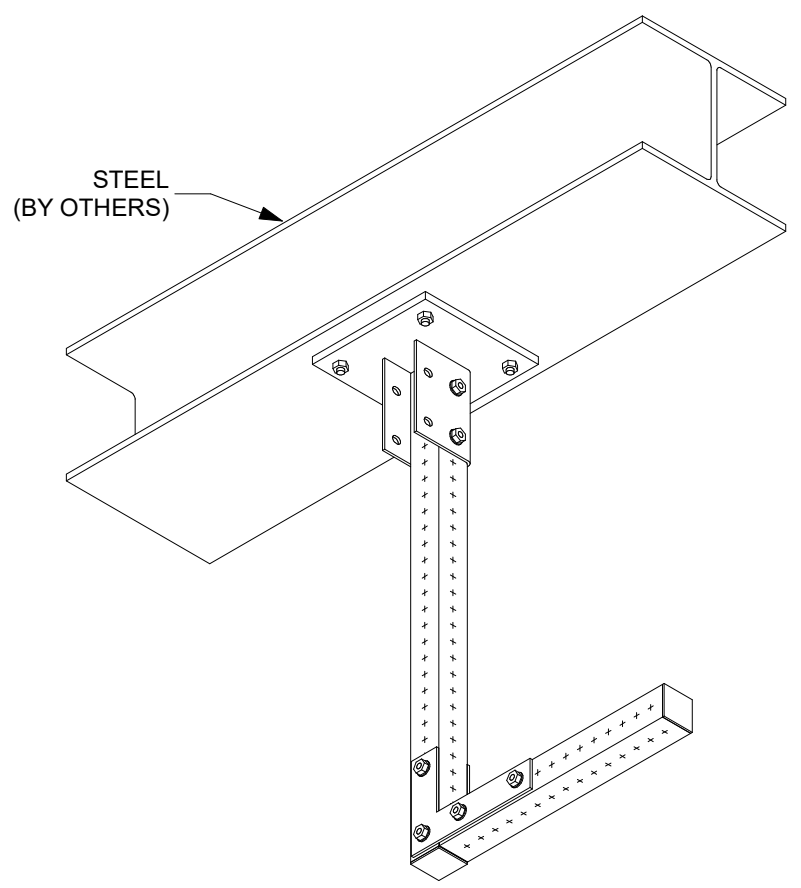

1 ISOMETRIC
N.T.S.

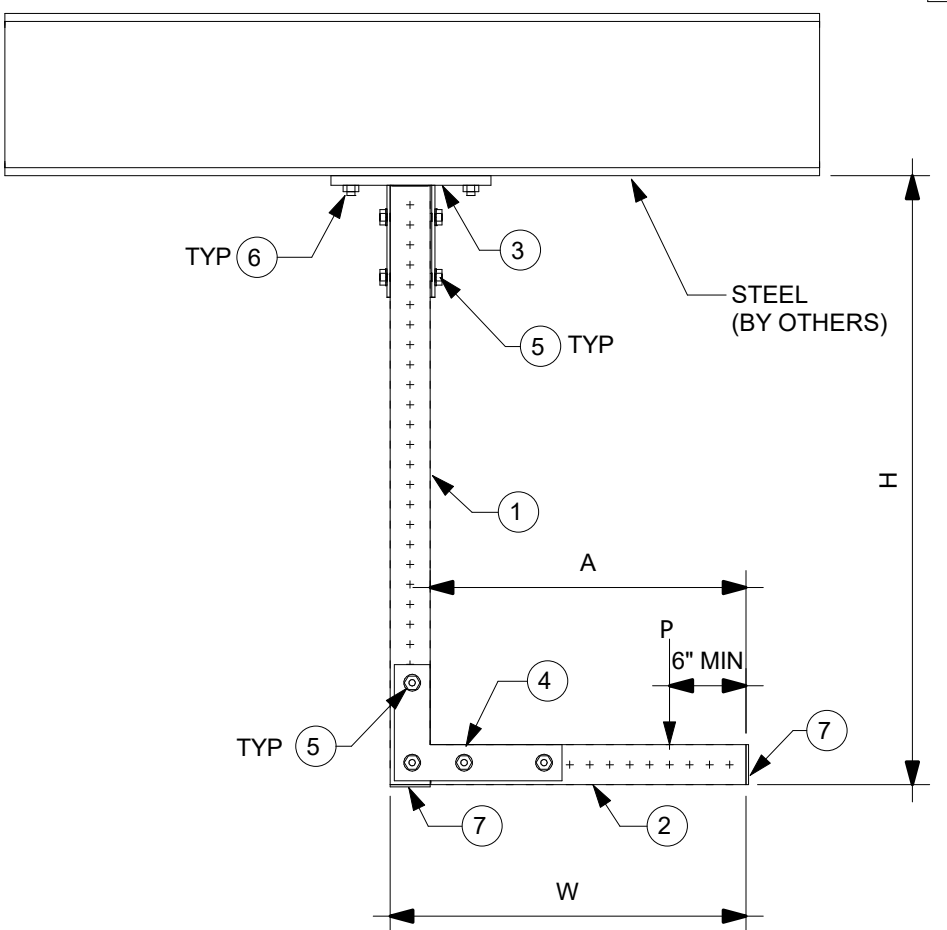

2 ELEVATION
N.T.S.

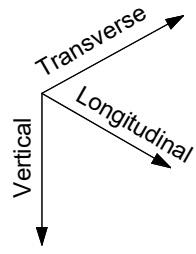

NOTE(S):

- A. THE TYPICAL SUPPORT IS LOAD RATED AND DIMENSIONALLY LIMITED BASED ON DESIGN METHODOLOGY AND GENERIC NON-PROJECT SPECIFIC ASSUMPTIONS SET FORTH IN PROFIS MODULAR SUPPORTS ENGINEERING SOFTWARE VERSION 1.3. THE ENGINEER OF RECORD SHALL EVALUATE THIS TYPICAL SUPPORT TO DETERMINE ITS SUITABILITY FOR THE ACTUAL PROJECT SPECIFIC DESIGN CRITERIA AND REQUIREMENTS.
- B. THE EVALUATION OF EXISTING STRUCTURE IS OUTSIDE OF THE TYPICAL DESIGN SCOPE AND SHALL BE PERFORMED BY THE ENGINEER OF RECORD.
- C. TYPICAL SUPPORT DESIGN IS BASED ON INTERNATIONAL BUILDING CODE (IBC) 2018. SEE TABLE-A FOR ALLOWABLE STRENGTH DESIGN LOADS (STATIC U.N.O.); GOVERNING LATERAL LOADS NOTED IN THE ALLOWABLE LOAD TABLE IS MAXIMUM OF 30% OF DEAD LOAD.
- D. ALL LOADS ASSUMED TO ACT ON THE SUPPORT, NO ECCENTRICITY CONSIDERED.
- E. MAXIMUM ALLOWABLE LOADS NOTED IN TABLE-A ARE BASED ON THE GOVERNING COMBINATION OF VERTICAL LOAD WITH TRANSVERSE LOAD OR VERTICAL LOAD WITH LONGITUDINAL LOAD. A SEPARATE ANALYSIS MUST BE PERFORMED WHEN TRANSVERSE AND LONGITUDINAL LOAD OCCURS SIMULTANEOUSLY.
- F. REFER TO HILTI INSTRUCTION FOR USE SHEET FOR REQUIRED INSTALLATION INFORMATION. THREAD FORMING BOLT MAY BE INSTALLED USING A TORQUE WRENCH OR SI-AT-A22 PER INSTRUCTION FOR USE.
- G. X-BT REQUIREMENT: MIN. STEEL BASE MATERIAL THICKNESS SHALL BE 5/16". MIN EDGE DISTANCE SHALL BE 3/8". MIN YIELD STRENGTH OF STEEL SHALL BE FY=36KSI.
- H. MINIMUM 8" FLANGE WIDTH REQUIRED.

	24	36
Max H, in	24	36
Max W, in	12	18
Max A, in	10-1/16	16-1/16
Vertical (P)	450	150
Transverse	135	45
Longitudinal	135	45

ALLOWABLE LOADS, lbs

REVISION HISTORY		DATE:	
NO:	DESCRIPTION:		
A	ISSUE FOR REVIEW	09/21/2020	
B	ISSUE FOR REVIEW	12/14/2020	
C	ISSUE FOR REVIEW - NOTE MODIFICATIONS AND DIM CALLOUTS	05/28/2021	

PROJECT NAME:
L FRAME MT70 S 001

PROJECT DESCRIPTION:
L FRAME MT70 S 001

DRAWN:	CHECKED:	DESIGNED:	REVIEWED:
GAB	IDP	JDR	BVD

PAPER SIZE: ANSI B

PROJECT NUMBER:
PROJECT - JOB - SHEET
- LF7S1 - 1

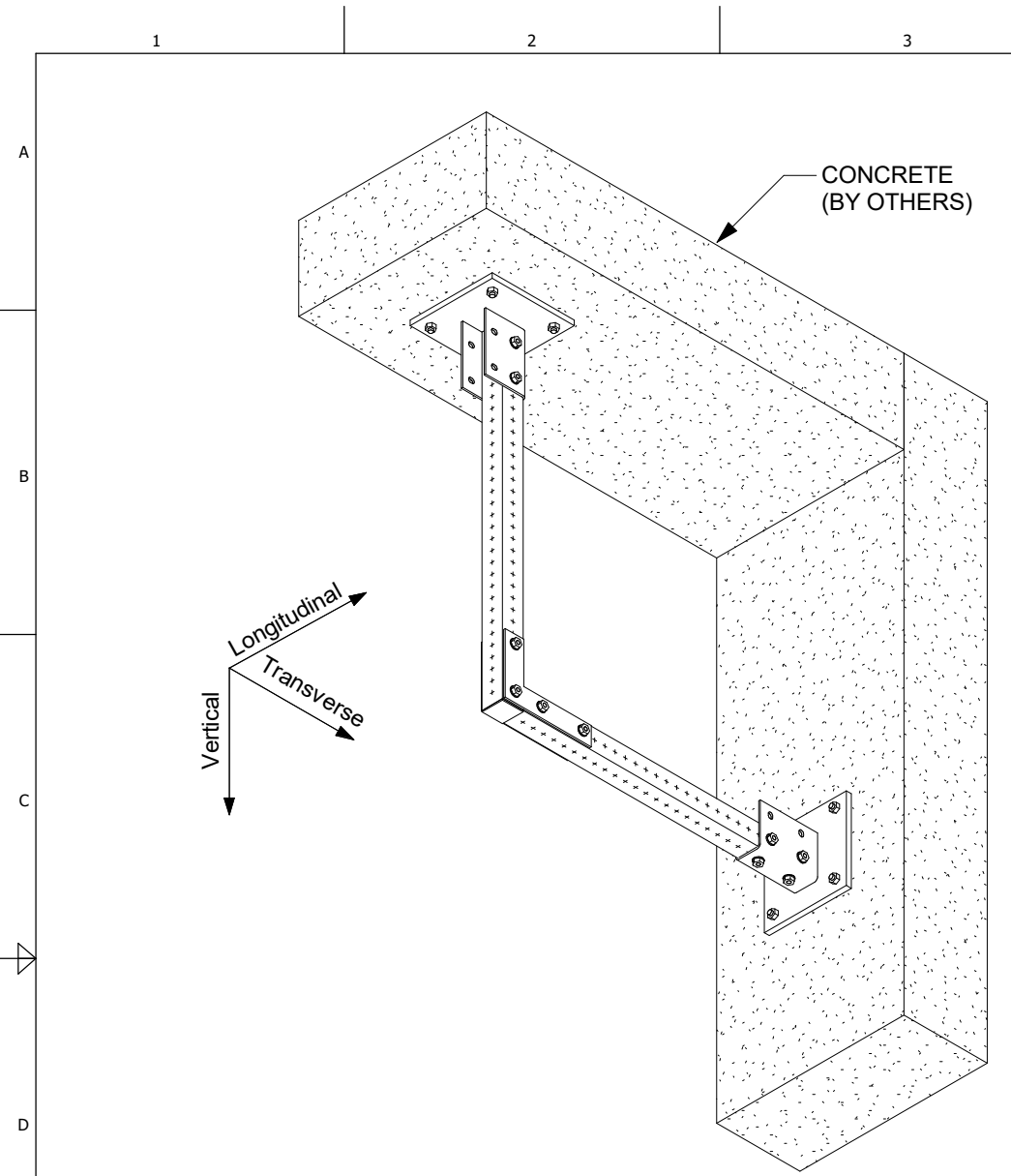

1 ISOMETRIC
N.T.S.

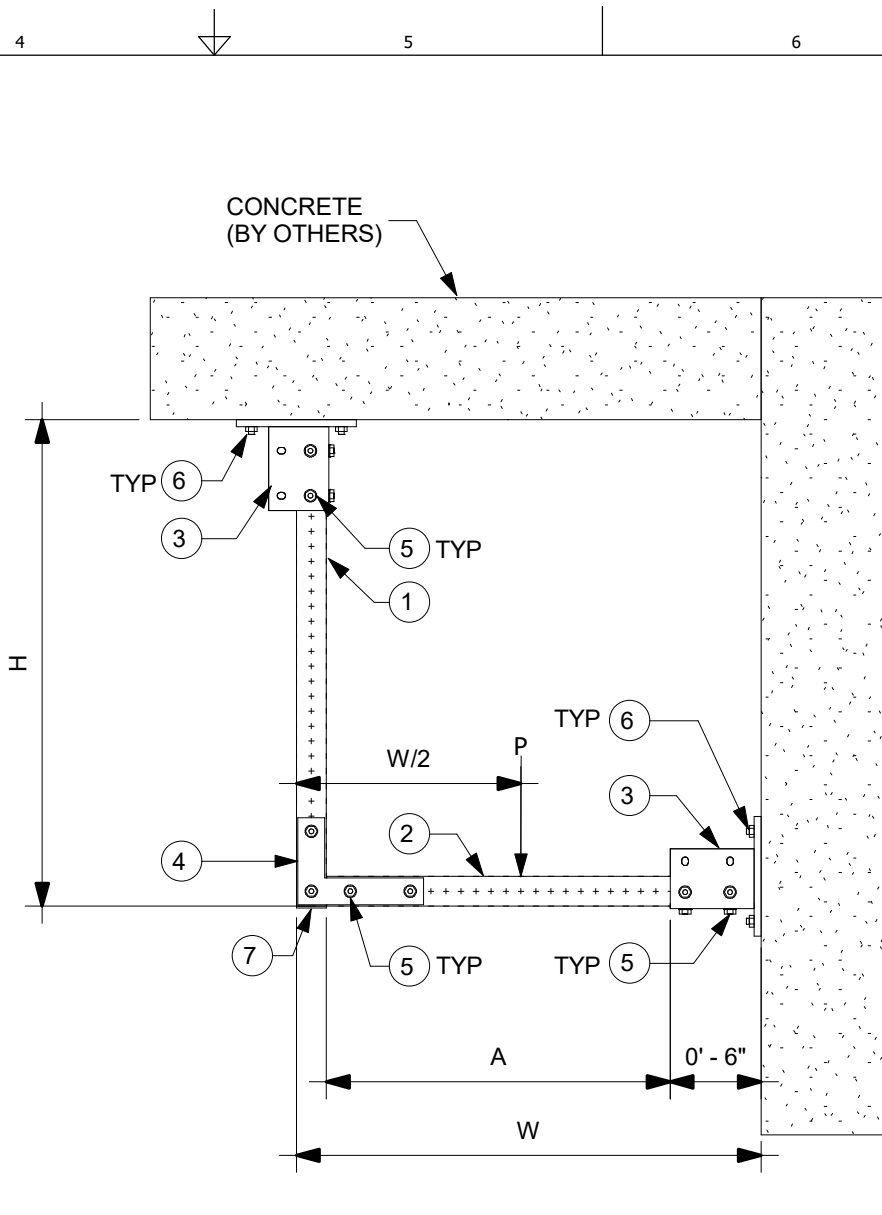

2 ELEVATION
N.T.S.

MARK	ITEM NO.	DESCRIPTION	QTY.
1	2268365	MT-70 OC	1
2	2268365	MT-70 OC	1
3	2272101	MT-B-GS O4U OC	2
4	2272073	MT-C-GSP L OC	2
5	2272084	MT-TFB OC	20
6	2210261	ANCHOR KB-TZ2 1/2" x 4-1/2" SS304	8
7	2273697	MT-EC-70	1

NOTE(S):

- A. THE TYPICAL SUPPORT IS LOAD RATED AND DIMENSIONALLY LIMITED BASED ON DESIGN METHODOLOGY AND GENERIC NON-PROJECT SPECIFIC ASSUMPTIONS SET FORTH IN PROFIS MODULAR SUPPORTS ENGINEERING SOFTWARE VERSION 1.3. THE ENGINEER OF RECORD SHALL EVALUATE THIS TYPICAL SUPPORT TO DETERMINE ITS SUITABILITY FOR THE ACTUAL PROJECT SPECIFIC DESIGN CRITERIA AND REQUIREMENTS.
- B. THE EVALUATION OF EXISTING STRUCTURE IS OUTSIDE OF THE TYPICAL DESIGN SCOPE AND SHALL BE PERFORMED BY THE ENGINEER OF RECORD.
- C. TYPICAL SUPPORT DESIGN IS BASED ON INTERNATIONAL BUILDING CODE (IBC) 2018. SEE TABLE-A FOR ALLOWABLE STRENGTH DESIGN LOADS (STATIC U.N.O.); GOVERNING LATERAL LOADS NOTED IN THE ALLOWABLE LOAD TABLE IS MAXIMUM OF 30% OF DEAD LOAD.
- D. ALL LOADS ASSUMED TO ACT ON THE SUPPORT, NO ECCENTRICITY CONSIDERED
- E. MAXIMUM ALLOWABLE LOADS NOTED IN TABLE-A ARE BASED ON THE GOVERNING COMBINATION OF VERTICAL LOAD WITH TRANSVERSE LOAD OR VERTICAL LOAD WITH LONGITUDINAL LOAD. A SEPARATE ANALYSIS MUST BE PERFORMED WHEN TRANSVERSE AND LONGITUDINAL LOAD OCCURS SIMULTANEOUSLY.
- F. REFER TO HILTI INSTRUCTION FOR USE SHEET FOR REQUIRED INSTALLATION INFORMATION.
- G. SEE BOM FOR KWIK BOLT-TZ2 ANCHOR BOLT. FOR 1/2" DIA. HILTI KWIK BOLT-TZ2 USE MIN. 3-1/4" EFFECTIVE EMBEDMENT. FOR 5/8" DIA. KWIK BOLT-TZ2 USE 3-1/4" MIN. EFFECTIVE EMBEDMENT. INSTALL ANCHOR PER ESR-4266 AND HILTI'S INSTRUCTIONS FOR USE AND RECOMMENDATIONS. MIN. CONCRETE COMPRESSIVE STRENGTH F'C=3000 PSI, MIN. CONCRETE EDGE DISTANCE = 6", AND MIN. CONCRETE THICKNESS = 6".
- H. CONCRETE ANCHORS NOTED IN THE BILL OF MATERIAL ARE DESIGNED ONLY FOR WIND LATERAL LOADING. ENGINEER OF RECORD TO VERIFY ADEQUACY OF ANCHOR WHEN TYPICAL IS BEING USED FOR SEISMIC LATERAL LOADING.

	24	36	48
Max H, in	24	36	48
Max W, in	24	36	48
Max A, in	16-1/16	28-1/16	40-1/16
Vertical (P)	1575	1050	800
Transverse	472	315	240
Longitudinal	472	315	240

ALLOWABLE LOADS, lbs

REVISION HISTORY			
NO:	DESCRIPTION:	DATE:	
B	ISSUE FOR REVIEW - UPDATED DIMENSIONS	03/03/2021	
C	ISSUE FOR BU USE	07/06/2021	
D	ANCHOR NOTE AND BOM MODIFICATION FOR ANCHOR	03/22/2022	

PROJECT NAME: L FRAME MT70 C 003

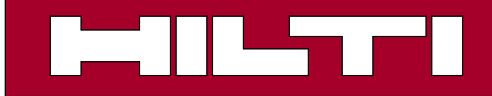

DRAWN:	CHECKED:	DESIGNED:	REVIEWED:
GAB	IDP	JDR	BVD

PROJECT DESCRIPTION: L FRAME MT70 C 003

PAPER SIZE:	PROJECT NUMBER:		
ANSI B	PROJECT	JOB	SHEET
	- LF7C3 -		1

MARK	ITEM NO.	DESCRIPTION	QTY.
1	2268365	MT-70 OC	1
2	2268365	MT-70 OC	1
3	2272101	MT-B-GS O4U OC	2
4	2272073	MT-C-GSP L OC	2
5	2272084	MT-TFB OC	20
6	2194341	X-BT-MR W10/15 SN 8	8
7	2273697	MT-EC-70	1

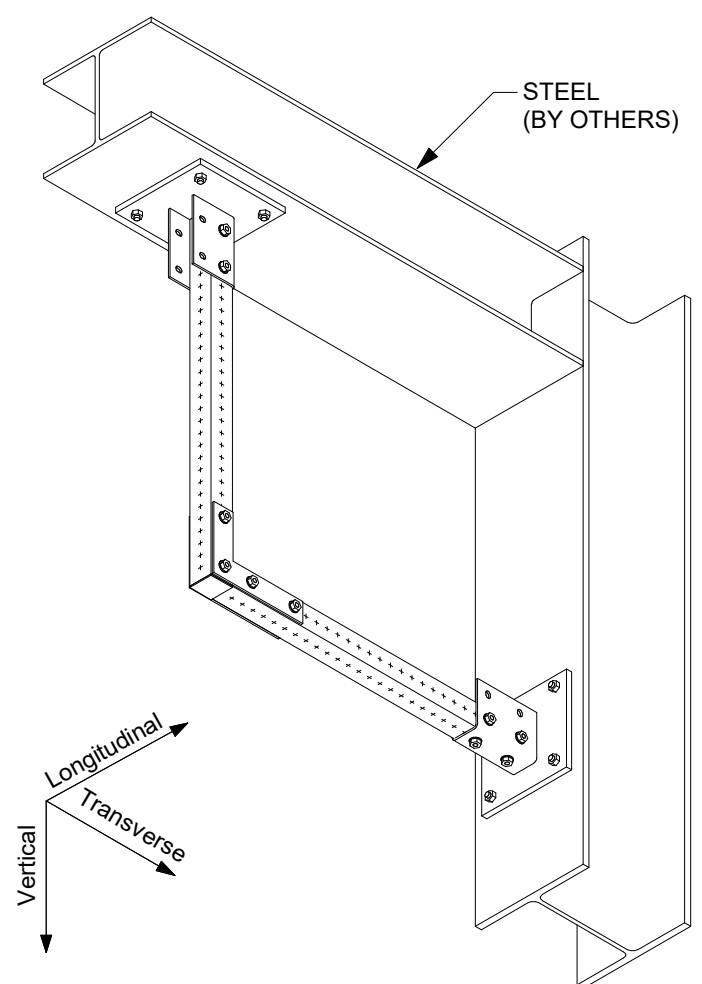

1 ISOMETRIC
N.T.S.

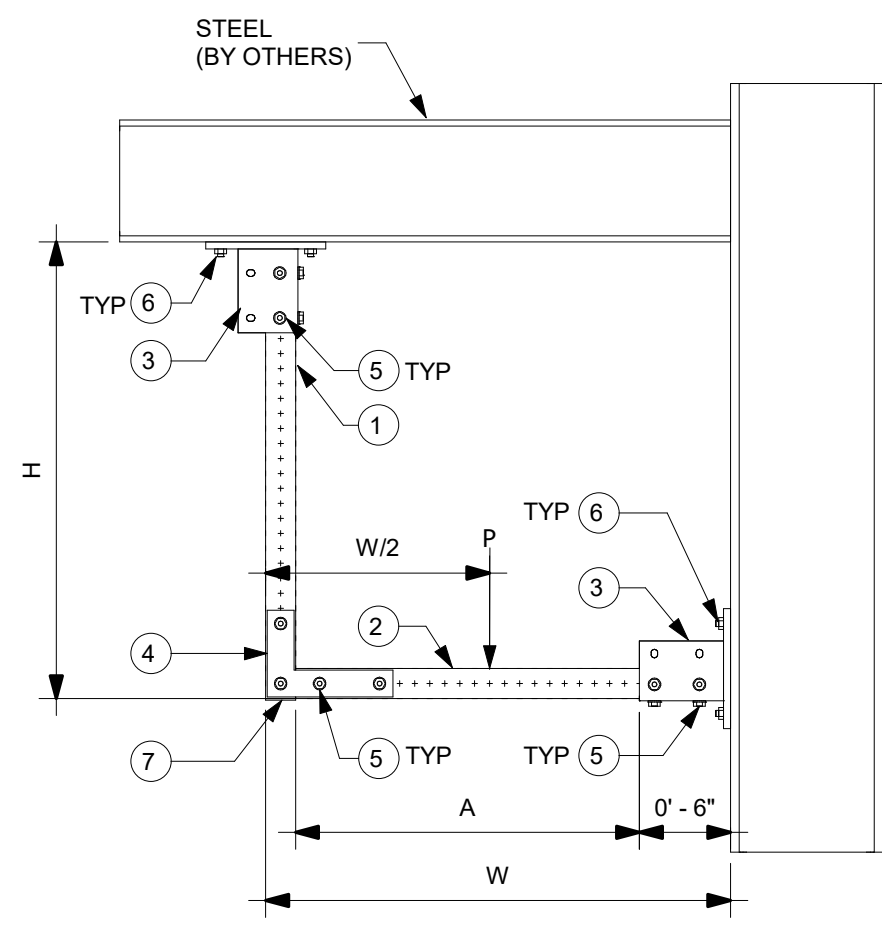

2 ELEVATION
N.T.S.

NOTE(S):

A. THE TYPICAL SUPPORT IS LOAD RATED AND DIMENSIONALLY LIMITED BASED ON DESIGN METHODOLOGY AND GENERIC NON-PROJECT SPECIFIC ASSUMPTIONS SET FORTH IN PROFIS MODULAR SUPPORTS ENGINEERING SOFTWARE VERSION 1.3. THE ENGINEER OF RECORD SHALL EVALUATE THIS TYPICAL SUPPORT TO DETERMINE ITS SUITABILITY FOR THE ACTUAL PROJECT SPECIFIC DESIGN CRITERIA AND REQUIREMENTS.

B. THE EVALUATION OF EXISTING STRUCTURE IS OUTSIDE OF THE TYPICAL DESIGN SCOPE AND SHALL BE PERFORMED BY THE ENGINEER OF RECORD.

C. TYPICAL SUPPORT DESIGN IS BASED ON INTERNATIONAL BUILDING CODE (IBC) 2018. SEE TABLE-A FOR ALLOWABLE STRENGTH DESIGN LOADS (STATIC U.N.O.); GOVERNING LATERAL LOADS NOTED IN THE ALLOWABLE LOAD TABLE IS MAXIMUM OF 30% OF DEAD LOAD.

D. ALL LOADS ASSUMED TO ACT ON THE SUPPORT, NO ECCENTRICITY CONSIDERED.

E. MAXIMUM ALLOWABLE LOADS NOTED IN TABLE-A ARE BASED ON THE GOVERNING COMBINATION OF VERTICAL LOAD WITH TRANSVERSE LOAD OR VERTICAL LOAD WITH LONGITUDINAL LOAD. A SEPARATE ANALYSIS MUST BE PERFORMED WHEN TRANSVERSE AND LONGITUDINAL LOAD OCCURS SIMULTANEOUSLY.

F. REFER TO HILTI INSTRUCTION FOR USE SHEET FOR REQUIRED INSTALLATION INFORMATION. THREAD FORMING BOLT MAY BE INSTALLED USING A TORQUE WRENCH OR SI-AT-A22 PER INSTRUCTION FOR USE.

G. X-BT REQUIREMENT: MIN. STEEL BASE MATERIAL THICKNESS SHALL BE 5/16". MIN EDGE DISTANCE SHALL BE 3/8". MIN YIELD STRENGTH OF STEEL SHALL BE FY=36KSI.

H. MINIMUM 8" FLANGE WIDTH REQUIREMENT.

	24	36	48
Max H, in	24	36	48
Max W, in	24	36	48
Max A, in	16-1/16	28-1/16	40-1/16
Vertical (P)	1150	825	625
Transverse	345	247	188
Longitudinal	345	247	188

ALLOWABLE LOADS, lbs

REVISION HISTORY		
NO.	DESCRIPTION:	DATE:
A	ISSUE FOR REVIEW	09/21/2020
B	ISSUE FOR REVIEW	12/14/2020
C	ISSUE FOR REVIEW - NOTE MODIFICATIONS AND DIM CALLOUTS	05/28/2021

PROJECT NAME: L FRAME MT70 S 003



PROJECT DESCRIPTION: L FRAME MT70 S 003

DRAWN:	CHECKED:	DESIGNED:	REVIEWED:
GAB	IDP	JDR	BVD
PAPER SIZE: ANSI B		PROJECT NUMBER: LF7S3 - 1	

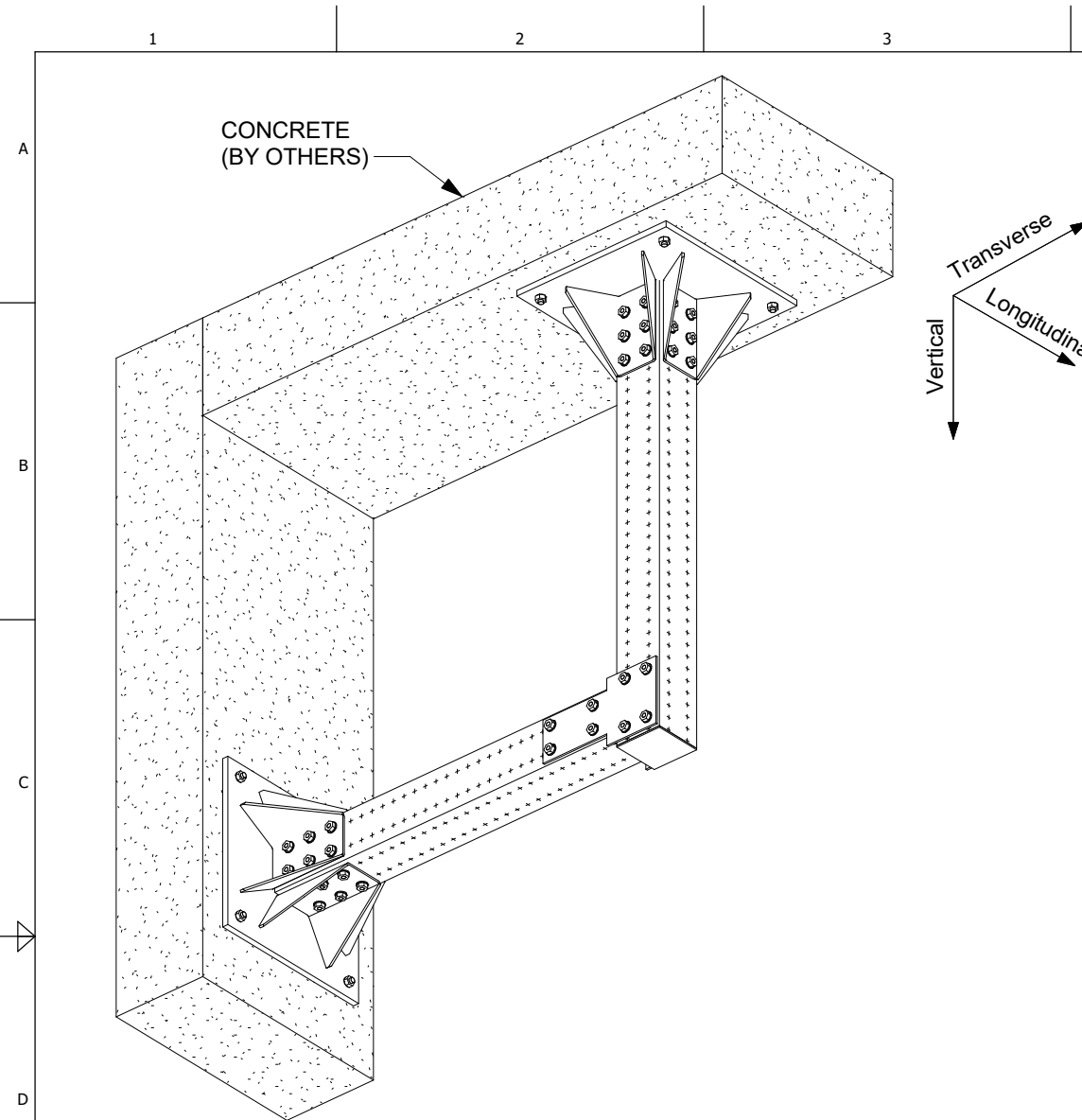

1 ISOMETRIC
N.T.S.

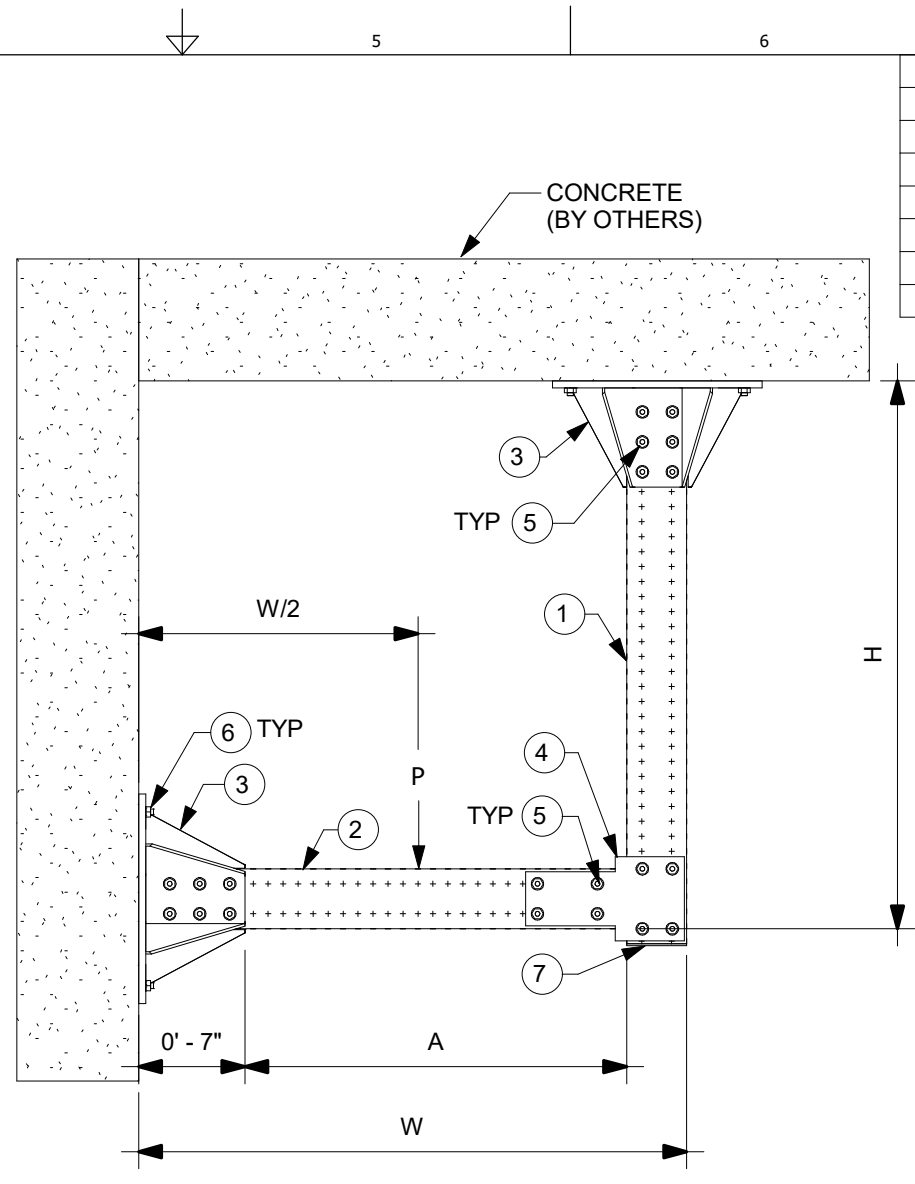

2 ELEVATION
N.T.S.

MARK	ITEM NO.	DESCRIPTION	QTY.
1	2268369	MT-90 OC	1
2	2268369	MT-90 OC	1
3	2272103	MT-B-GL-O4 OC	2
4	2272075	MT-C-GLP T OC	2
5	2272084	MT-TFB OC	64
6	2210278	ANCHOR KB-TZ2 5/8" X 4-3/4" SS304	8
7	2273699	MT-EC-90	1

NOTE(S):

A. THE TYPICAL SUPPORT IS LOAD RATED AND DIMENSIONALLY LIMITED BASED ON DESIGN METHODOLOGY AND GENERIC NON-PROJECT SPECIFIC ASSUMPTIONS SET FORTH IN PROFIS MODULAR SUPPORTS ENGINEERING SOFTWARE VERSION 1.3. THE ENGINEER OF RECORD SHALL EVALUATE THIS TYPICAL SUPPORT TO DETERMINE ITS SUITABILITY FOR THE ACTUAL PROJECT SPECIFIC DESIGN CRITERIA AND REQUIREMENTS.

B. THE EVALUATION OF EXISTING STRUCTURE IS OUTSIDE OF THE TYPICAL DESIGN SCOPE AND SHALL BE PERFORMED BY THE ENGINEER OF RECORD.

C. TYPICAL SUPPORT DESIGN IS BASED ON INTERNATIONAL BUILDING CODE (IBC) 2018. SEE TABLE-A FOR ALLOWABLE STRENGTH DESIGN LOADS (STATIC U.N.O.); GOVERNING LATERAL LOADS NOTED IN THE ALLOWABLE LOAD TABLE IS MAXIMUM OF 30% OF DEAD LOAD.

D. ALL LOADS ASSUMED TO ACT ON THE SUPPORT, NO ECCENTRICITY CONSIDERED

E. MAXIMUM ALLOWABLE LOADS NOTED IN TABLE-A ARE BASED ON THE GOVERNING COMBINATION OF VERTICAL LOAD WITH TRANSVERSE LOAD OR VERTICAL LOAD WITH LONGITUDINAL LOAD. A SEPARATE ANALYSIS MUST BE PERFORMED WHEN TRANSVERSE AND LONGITUDINAL LOAD OCCURS SIMULTANEOUSLY.

F. REFER TO HILTI INSTRUCTION FOR USE SHEET FOR REQUIRED INSTALLATION INFORMATION. THREAD FORMING BOLD MAY BE INSTALLED USING A TORQUE WRENCH OR SI-AT-A22 PER INSTRUCTION FOR USE.

G. SEE BOM FOR KWIK BOLT-TZ2 ANCHOR BOLT. FOR 1/2" DIA. HILTI KWIK BOLT-TZ2 USE MIN. 3-1/4" EFFECTIVE EMBEDMENT. FOR 5/8" DIA. KWIK BOLT-TZ2 USE 3-1/4" MIN. EFFECTIVE EMBEDMENT. INSTALL ANCHOR PER ESR-4266 AND HILTI'S INSTRUCTIONS FOR USE AND RECOMMENDATIONS. MIN. CONCRETE COMPRESSIVE STRENGTH $f'_c=3000$ PSI, MIN. CONCRETE EDGE DISTANCE = 6", AND MIN. CONCRETE THICKNESS = 6".

H. CONCRETE ANCHORS NOTED IN THE BILL OF MATERIAL ARE DESIGNED ONLY FOR WIND LATERAL LOADING. ENGINEER OF RECORD TO VERIFY ADEQUACY OF ANCHOR WHEN TYPICAL IS BEING USED FOR SEISMIC LATERAL LOADING

	48	60
Max H, in	48	60
Max W, in	48	60
Max A, in	37-1/16	49-1/16
Vertical (P)	3300	2200
Transverse	990	660
Longitudinal	990	660

ALLOWABLE LOADS, lbs

REVISION HISTORY		DATE:	
NO:	DESCRIPTION:		
B	NOTE MODIFICATIONS	01/29/2021	
C	ISSUE FOR BU USE	07/06/2021	
D	ANCHOR NOTE AND BOM MODIFICATION FOR ANCHOR	03/22/2022	

PROJECT NAME: L FRAME MT90 C 001

PROJECT DESCRIPTION: L FRAME MT90 C 001

HILTI			
DRAWN:	CHECKED:	DESIGNED:	REVIEWED:
GAB	IDP	JDR	BVD
PAPER SIZE: ANSI B		PROJECT NUMBER: LF9C1 - 1	

MARK	ITEM NO.	DESCRIPTION	QTY.
1	2268369	MT-90 OC	1
2	2268369	MT-90 OC	1
3	VARIABLES	MT-B-GXL S+ OC (SEE TABLE)	2
4	2272075	MT-C-GLP T OC	2
5	2272084	MT-TFB OC	52
6	387398	MI-SGC M16	8
7	2273699	MT-EC-90	1

MT-B-GXL S+ OC		
+	'B' Width	Item No.
1	2.9 to 6.5	2272106
2	6.5 to 9.2	2272107
3	9.2 to 11.8	2272108

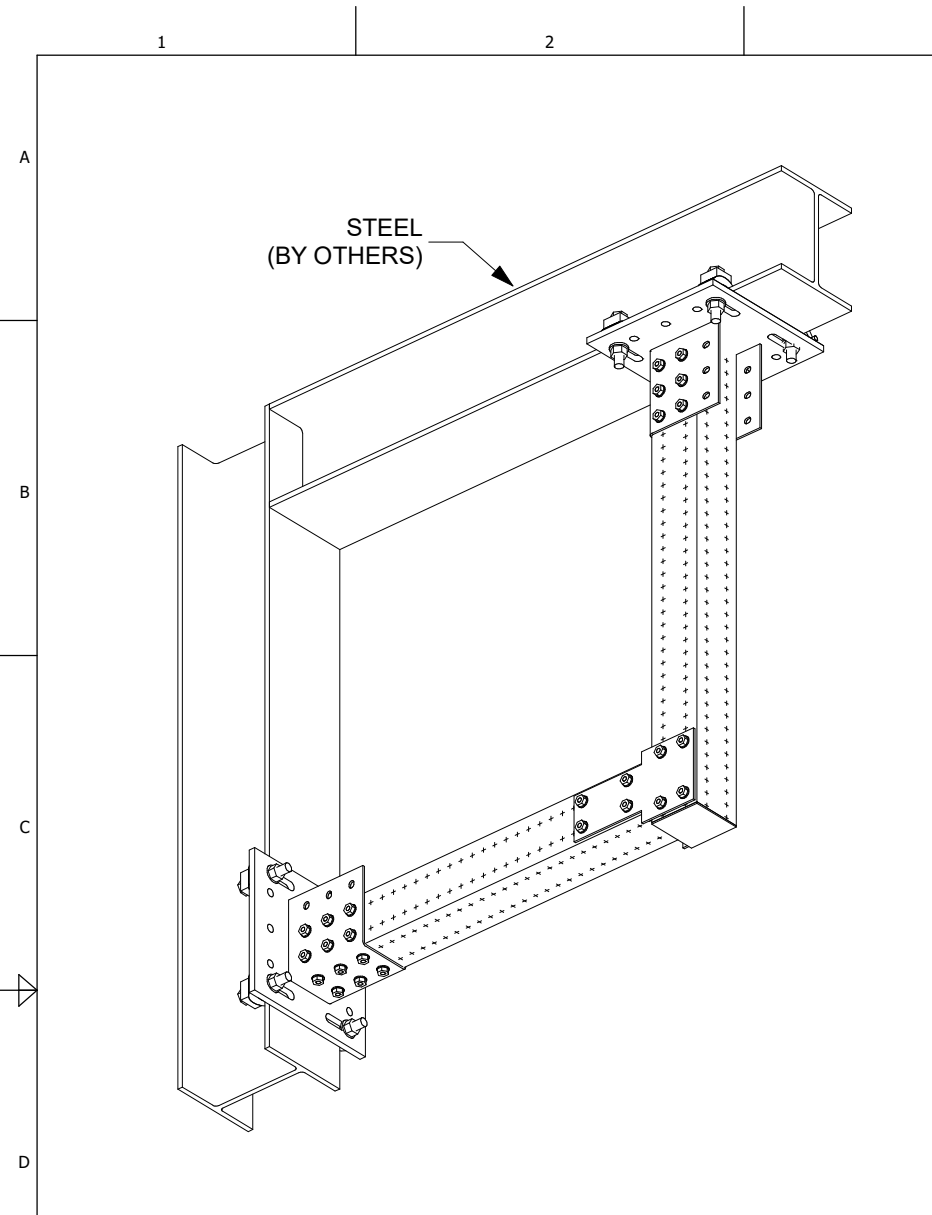

1 ISOMETRIC
N.T.S.

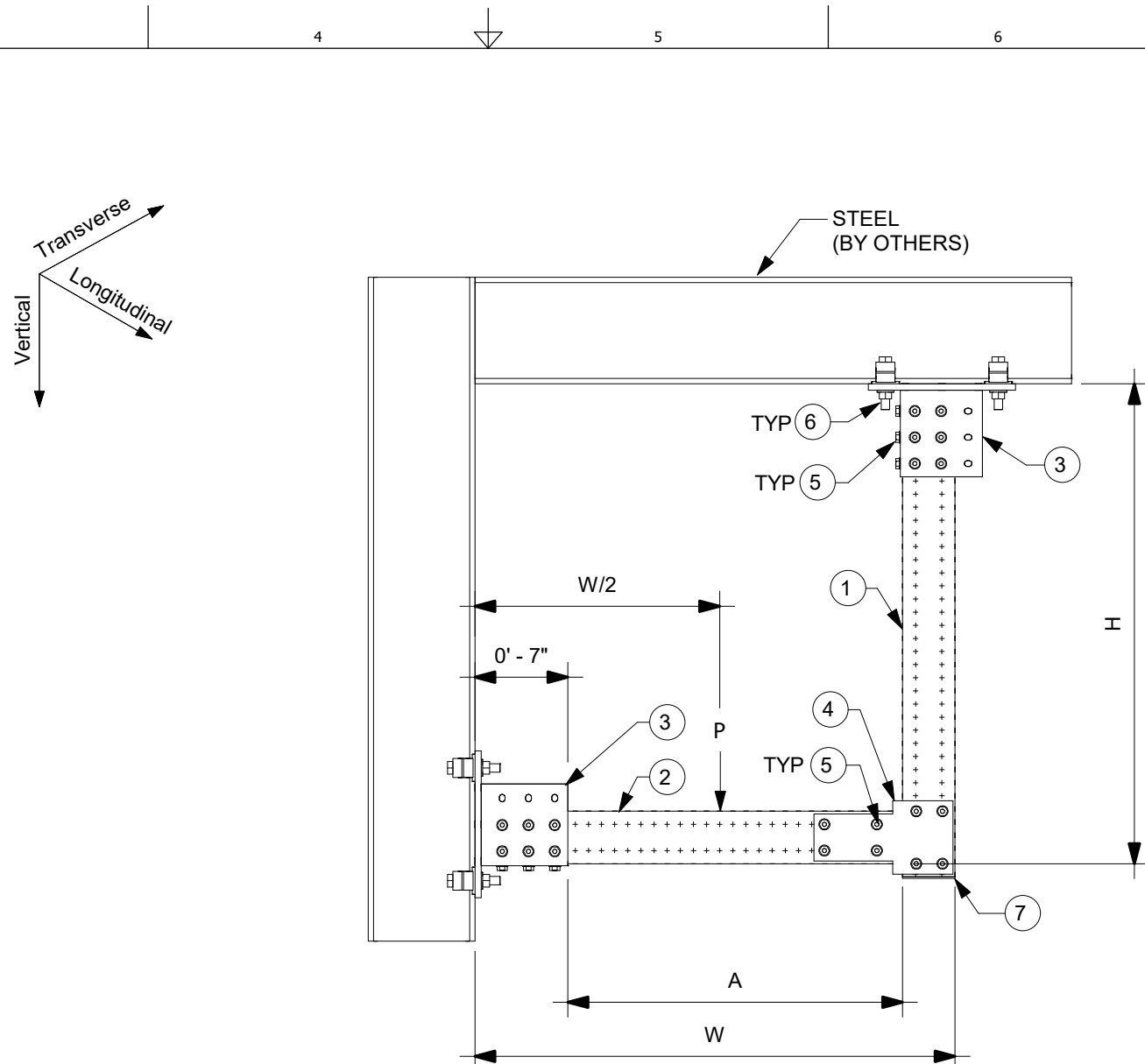

2 ELEVATION
N.T.S.

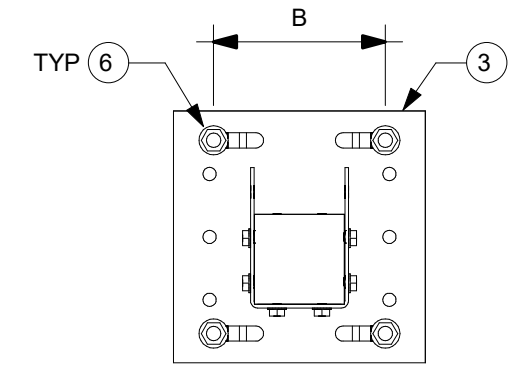

3 BASEPLATE DETAIL
N.T.S.

NOTE(S):

A. THE TYPICAL SUPPORT IS LOAD RATED AND DIMENSIONALLY LIMITED BASED ON DESIGN METHODOLOGY AND GENERIC NON-PROJECT SPECIFIC ASSUMPTIONS SET FORTH IN PROFIS MODULAR SUPPORTS ENGINEERING SOFTWARE VERSION 1.3. THE ENGINEER OF RECORD SHALL EVALUATE THIS TYPICAL SUPPORT TO DETERMINE ITS SUITABILITY FOR THE ACTUAL PROJECT SPECIFIC DESIGN CRITERIA AND REQUIREMENTS.

B. THE EVALUATION OF EXISTING STRUCTURE IS OUTSIDE OF THE TYPICAL DESIGN SCOPE AND SHALL BE PERFORMED BY THE ENGINEER OF RECORD.

C. TYPICAL SUPPORT DESIGN IS BASED ON INTERNATIONAL BUILDING CODE (IBC) 2018. SEE TABLE-A FOR ALLOWABLE STRENGTH DESIGN LOADS (STATIC U.N.O.); GOVERNING LATERAL LOADS NOTED IN THE ALLOWABLE LOAD TABLE IS MAXIMUM OF 30% OF DEAD LOAD.

D. ALL LOADS ASSUMED TO ACT ON THE SUPPORT, NO ECCENTRICITY CONSIDERED.

E. MAXIMUM ALLOWABLE LOADS NOTED IN TABLE-A ARE BASED ON THE GOVERNING COMBINATION OF VERTICAL LOAD WITH TRANSVERSE LOAD OR VERTICAL LOAD WITH LONGITUDINAL LOAD. A SEPARATE ANALYSIS MUST BE PERFORMED WHEN TRANSVERSE AND LONGITUDINAL LOAD OCCURS SIMULTANEOUSLY.

F. REFER TO HILTI INSTRUCTION FOR USE SHEET FOR REQUIRED INSTALLATION INFORMATION. THREAD FORMING BOLT MAY BE INSTALLED USING A TORQUE WRENCH OR SI-AT-A22 PER INSTRUCTION FOR USE.

	48	60
Max H, in	48	60
Max W, in	48	60
Max A, in	37-1/8	49-1/8
Vertical (P)	1900	1900
Transverse	570	570
Longitudinal	570	570

ALLOWABLE LOADS, lbs

REVISION HISTORY		
NO.	DESCRIPTION:	DATE:
A	ISSUE FOR REVIEW	12/18/2020
B	NOTE MODIFICATIONS	01/29/2021
C	ISSUE FOR REVIEW - NOTE MODIFICATIONS AND DIM CALLOUTS	05/28/2021

PROJECT NAME:
L FRAME MT90 S 001

PROJECT DESCRIPTION:
L FRAME MT90 S 001



DRAWN:	CHECKED:	DESIGNED:	REVIEWED:
GAB	IDP	JDR	BVD
PAPER SIZE: ANSI B		PROJECT NUMBER: PROJECT JOB SHEET - LF9S1 - 1	

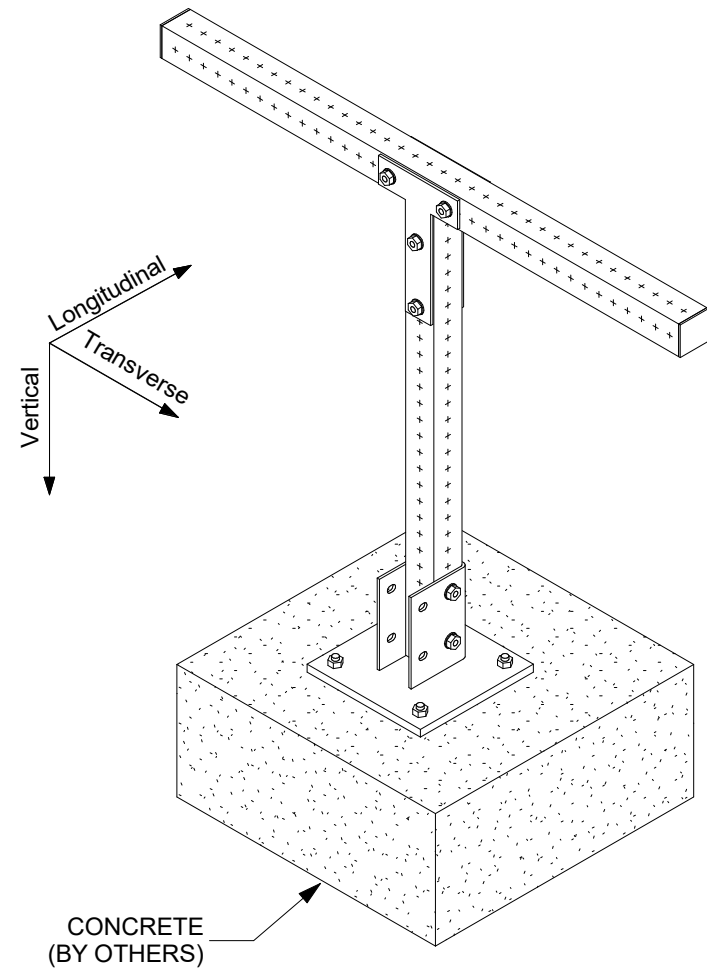

1 ISOMETRIC
N.T.S.

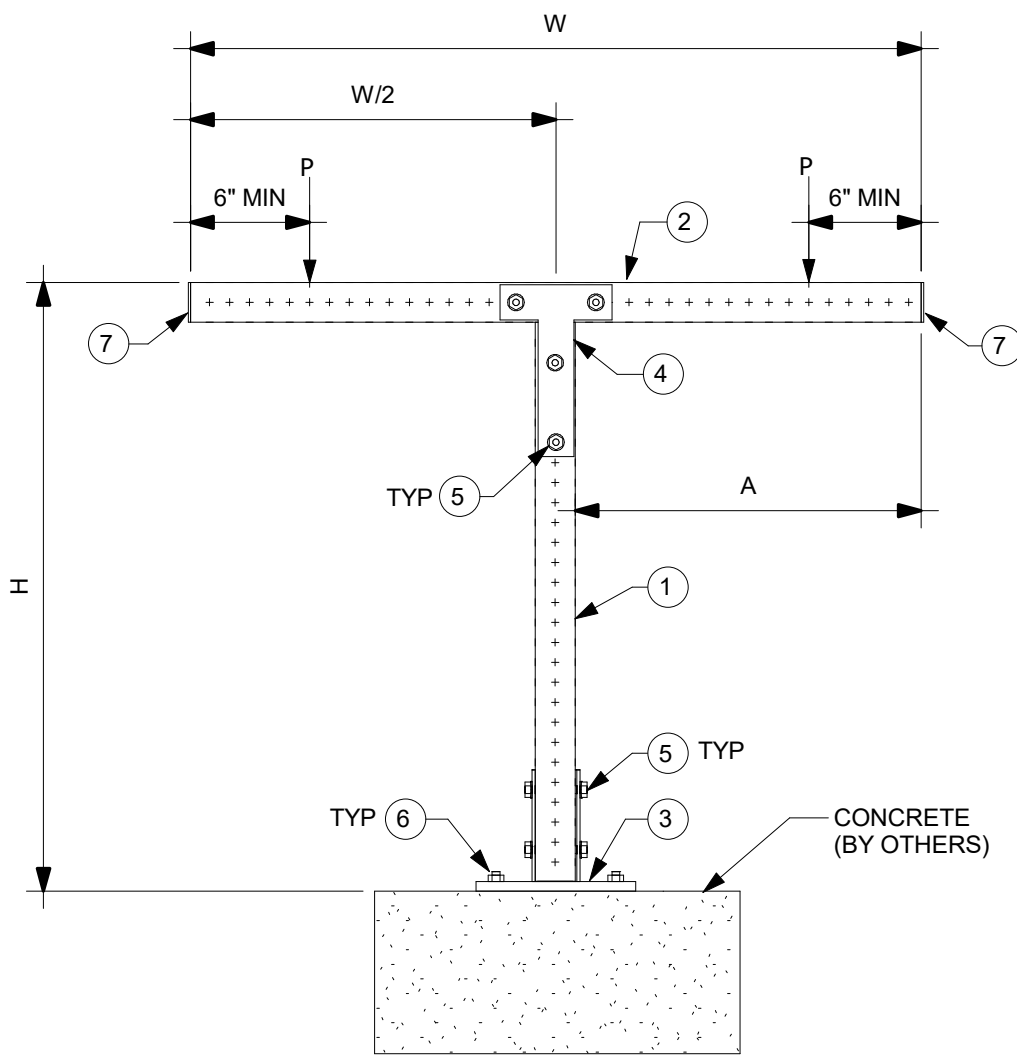

2 ELEVATION
N.T.S.

MARK	ITEM NO.	DESCRIPTION	QTY.
1	2268365	MT-70 OC	1
2	2268365	MT-70 OC	1
3	2272101	MT-B-GS O4U OC	1
4	2272074	MT-C-GSP T OC	2
5	2272084	MT-TFB OC	14
6	2210261	ANCHOR KB-TZ2 1/2" x 4-1/2" SS304	4
7	2273697	MT-EC-70	2

NOTE(S):

A. THE TYPICAL SUPPORT IS LOAD RATED AND DIMENSIONALLY LIMITED BASED ON DESIGN METHODOLOGY AND GENERIC NON-PROJECT SPECIFIC ASSUMPTIONS SET FORTH IN PROFIS MODULAR SUPPORTS ENGINEERING SOFTWARE VERSION 1.3. THE ENGINEER OF RECORD SHALL EVALUATE THIS TYPICAL SUPPORT TO DETERMINE ITS SUITABILITY FOR THE ACTUAL PROJECT SPECIFIC DESIGN CRITERIA AND REQUIREMENTS.

B. THE EVALUATION OF EXISTING STRUCTURE IS OUTSIDE OF THE TYPICAL DESIGN SCOPE AND SHALL BE PERFORMED BY THE ENGINEER OF RECORD.

C. TYPICAL SUPPORT DESIGN IS BASED ON INTERNATIONAL BUILDING CODE (IBC) 2018. SEE TABLE-A FOR ALLOWABLE STRENGTH DESIGN LOADS (STATIC U.N.O.); GOVERNING LATERAL LOADS NOTED IN THE ALLOWABLE LOAD TABLE IS MAXIMUM OF 30% OF DEAD LOAD OR WIND LOADING BASED ON WIND CRITERIA NOTED ON WIND DESIGN BASIS SHEET.

D. ALL LOADS ASSUMED TO ACT ON THE SUPPORT, NO ECCENTRICITY CONSIDERED

E. MAXIMUM ALLOWABLE LOADS NOTED IN TABLE-A ARE BASED ON THE GOVERNING COMBINATION OF VERTICAL LOAD WITH TRANSVERSE LOAD OR VERTICAL LOAD WITH LONGITUDINAL LOAD EQUAL DISTANCE FROM END. A SEPARATE ANALYSIS MUST BE PERFORMED WHEN TRANSVERSE AND LONGITUDINAL LOAD OCCURS SIMULTANEOUSLY.

F. REFER TO HILTI INSTRUCTION FOR USE SHEET FOR REQUIRED INSTALLATION INFORMATION.

G. SEE BOM FOR KWIK BOLT-TZ2 ANCHOR BOLT. FOR 1/2" DIA. HILTI KWIK BOLT-TZ2 USE MIN. 3-1/4" EFFECTIVE EMBEDMENT. FOR 5/8" DIA. KWIK BOLT-TZ2 USE 3-1/4" MIN. EFFECTIVE EMBEDMENT. INSTALL ANCHOR PER ESR-4266 AND HILTI'S INSTRUCTIONS FOR USE AND RECOMMENDATIONS. MIN. CONCRETE COMPRESSIVE STRENGTH $f'_c=3000$ PSI, MIN. CONCRETE EDGE DISTANCE = 6", AND MIN. CONCRETE THICKNESS = 6".

H. CONCRETE ANCHORS NOTED IN THE BILL OF MATERIAL ARE DESIGNED ONLY FOR WIND LATERAL LOADING. ENGINEER OF RECORD TO VERIFY ADEQUACY OF ANCHOR WHEN TYPICAL IS BEING USED FOR SEISMIC LATERAL LOADING.

I. LOADS ASSUMED TO BE LOCATED SYMMETRICALLY ON THE SUPPORT.

	24	36	48
Max H, in	24	36	48
Max W, in	24	36	48
Max A, in	11-1/16	17-1/16	23-1/16
Vertical (P)	375	160	90
Transverse	112	48	27
Longitudinal	112	48	27

ALLOWABLE LOADS, lbs

All loading and design criteria supplied by customer is assumed accurate. Only the stated Design Assumptions were considered, and must be verified by the responsible Engineer of Record (EOR). The basis of Hilti component and connection design is the published data in the current Hilti Technical Guide, including material and cross-section properties, allowable load values, factors of safety, methods of calculation, and limiting factors. The EOR must verify suitability for any specific application, and the capacity of the supportive structure to receive the shown configuration and associated reaction loads. Modification to components and/or design may alter performance and must be evaluated by the EOR.

REVISION HISTORY

NO.	DESCRIPTION:	DATE:
B	ISSUE FOR REVIEW - UPDATED DIMENSIONS	03/03/2021
C	ISSUE FOR BU USE	07/06/2021
D	ANCHOR NOTE AND BOM MODIFICATION FOR ANCHOR	03/22/2022

PROJECT NAME:

T POST MT70 C 001

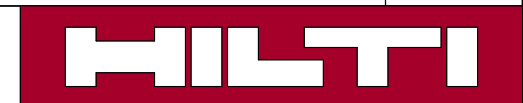

PROJECT DESCRIPTION:

T POST MT70 C 001

DRAWN:	CHECKED:	DESIGNED:	REVIEWED:
GAB	IDP	JDR	BVD
PAPER SIZE:		PROJECT NUMBER:	
ANSI B		PROJECT	JOB
		- TP7C1 -	
		SHEET	
		- 1 -	

MARK	ITEM NO.	DESCRIPTION	QTY.
1	2268365	MT-70 OC	1
2	2268365	MT-70 OC	1
3	2272101	MT-B-GS O4U OC	1
4	2272074	MT-C-GSP T OC	2
5	2272084	MT-TFB OC	14
6	2194341	X-BT-MR W10/15 SN 8	4
7	2273697	MT-EC-70	2

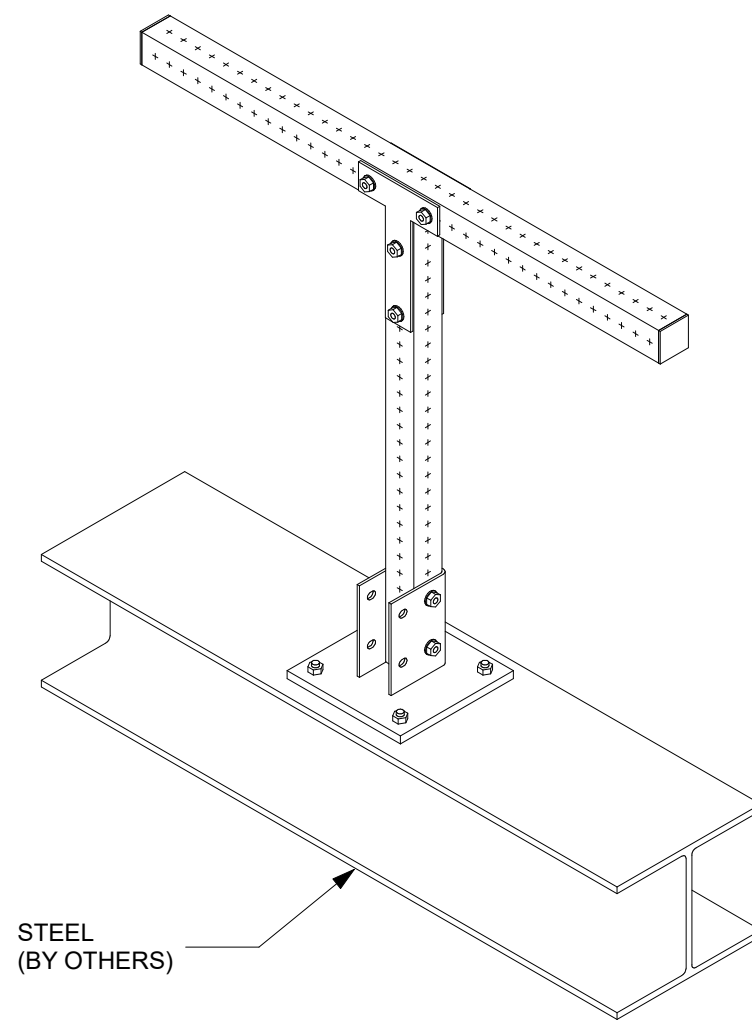

1 ISOMETRIC
N.T.S.

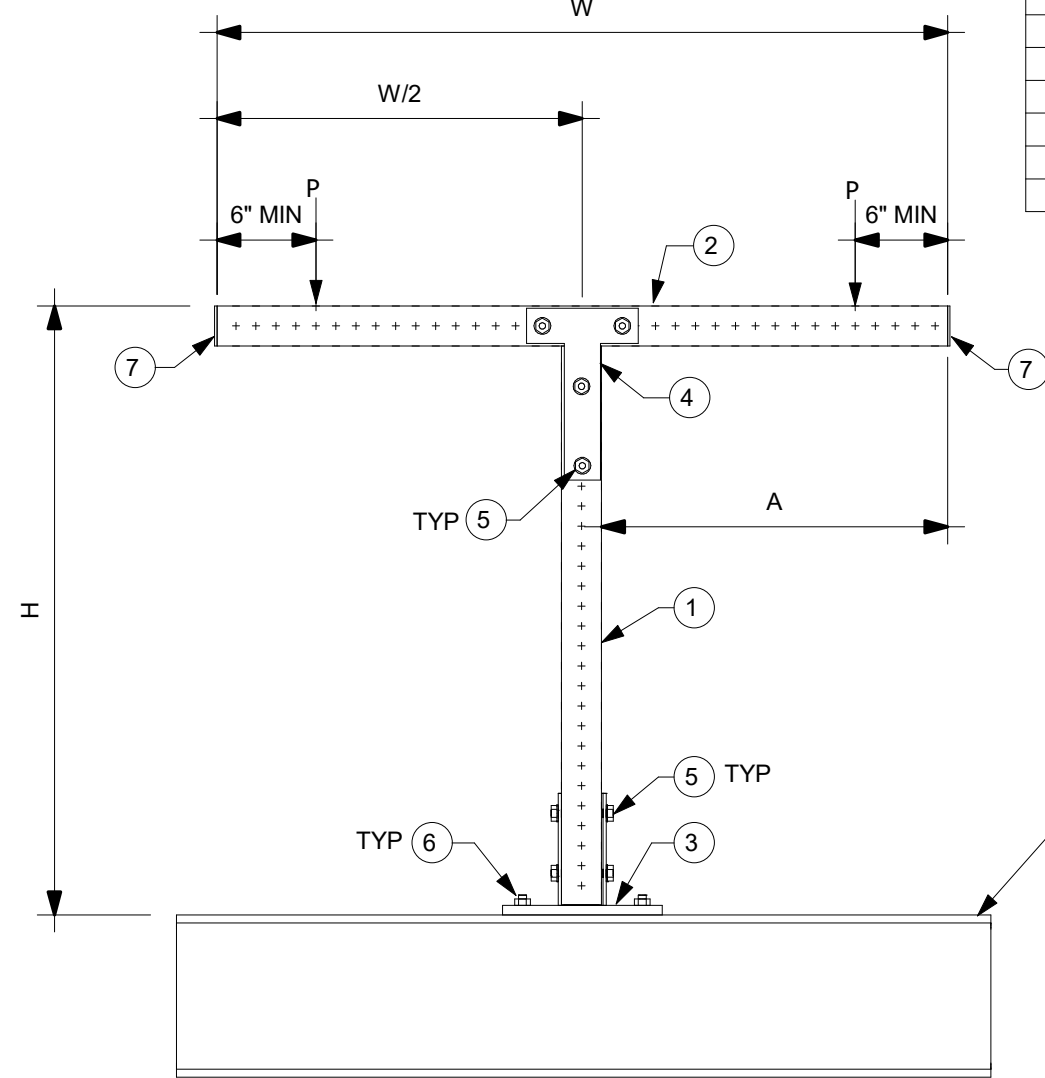

2 ELEVATION
N.T.S.

NOTE(S):

A. THE TYPICAL SUPPORT IS LOAD RATED AND DIMENSIONALLY LIMITED BASED ON DESIGN METHODOLOGY AND GENERIC NON-PROJECT SPECIFIC ASSUMPTIONS SET FORTH IN PROFIS MODULAR SUPPORTS ENGINEERING SOFTWARE VERSION 1.3. THE ENGINEER OF RECORD SHALL EVALUATE THIS TYPICAL SUPPORT TO DETERMINE ITS SUITABILITY FOR THE ACTUAL PROJECT SPECIFIC DESIGN CRITERIA AND REQUIREMENTS.

B. THE EVALUATION OF EXISTING STRUCTURE IS OUTSIDE OF THE TYPICAL DESIGN SCOPE AND SHALL BE PERFORMED BY THE ENGINEER OF RECORD.

C. TYPICAL SUPPORT DESIGN IS BASED ON INTERNATIONAL BUILDING CODE (IBC) 2018. SEE TABLE-A FOR ALLOWABLE STRENGTH DESIGN LOADS (STATIC U.N.O.); GOVERNING LATERAL LOADS NOTED IN THE ALLOWABLE LOAD TABLE IS MAXIMUM OF 30% OF DEAD LOAD.

D. ALL LOADS ASSUMED TO ACT ON THE SUPPORT, NO ECCENTRICITY CONSIDERED.

E. MAXIMUM ALLOWABLE LOADS NOTED IN TABLE-A ARE BASED ON THE GOVERNING COMBINATION OF VERTICAL LOAD WITH TRANSVERSE LOAD OR VERTICAL LOAD WITH LONGITUDINAL LOAD EQUAL DISTANCE FROM END. A SEPARATE ANALYSIS MUST BE PERFORMED WHEN TRANSVERSE AND LONGITUDINAL LOAD OCCURS SIMULTANEOUSLY.

F. REFER TO HILTI INSTRUCTION FOR USE SHEET FOR REQUIRED INSTALLATION INFORMATION. THREAD FORMING BOLT MAY BE INSTALLED USING A TORQUE WRENCH OR SI-AT-A22 PER INSTRUCTION FOR USE.

G. X-BT REQUIREMENT: MIN. STEEL BASE MATERIAL THICKNESS SHALL BE 5/16". MIN EDGE DISTANCE SHALL BE 3/8". MIN YIELD STRENGTH OF STEEL SHALL BE FY=36KSI.

H. MINIMUM 8" FLANGE WIDTH REQUIRED.

I. LOADS ASSUMED TO BE LOCATED SYMMETRICALLY ON THE SUPPORT.

	24	36	48
Max H, in	24	36	48
Max W, in	24	36	48
Max A, in	11-1/16	17-1/16	23-1/16
Vertical (P)	375	160	90
Transverse	112	48	27
Longitudinal	112	48	27

ALLOWABLE LOADS, lbs

REVISION HISTORY		
NO.	DESCRIPTION:	DATE:
A	ISSUE FOR REVIEW	09/21/2020
B	ISSUE FOR REVIEW	12/14/2020
C	ISSUE FOR REVIEW - NOTE MODIFICATIONS AND DIM CALLOUTS	05/28/2021

PROJECT NAME: T POST MT70 S 002

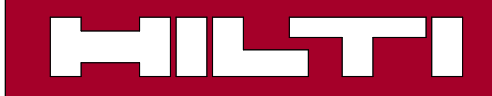

PROJECT DESCRIPTION: T POST MT70 S 002

DRAWN:	CHECKED:	DESIGNED:	REVIEWED:
GAB	IDP	JDR	BVD
PAPER SIZE: ANSI B		PROJECT NUMBER: TP7S2 - 1	

1 2 3 4 5 6 7 8

MARK	ITEM NO.	DESCRIPTION	QTY.
1	2268365	MT-70 OC	1
2	2268365	MT-70 OC	1
3	2272101	MT-B-GS O4U OC	1
4	2272074	MT-C-GSP T OC	2
5	2272084	MT-TFB OC	14
6	2194341	X-BT-MR W10/15 SN 8	4
7	2273697	MT-EC-70	2

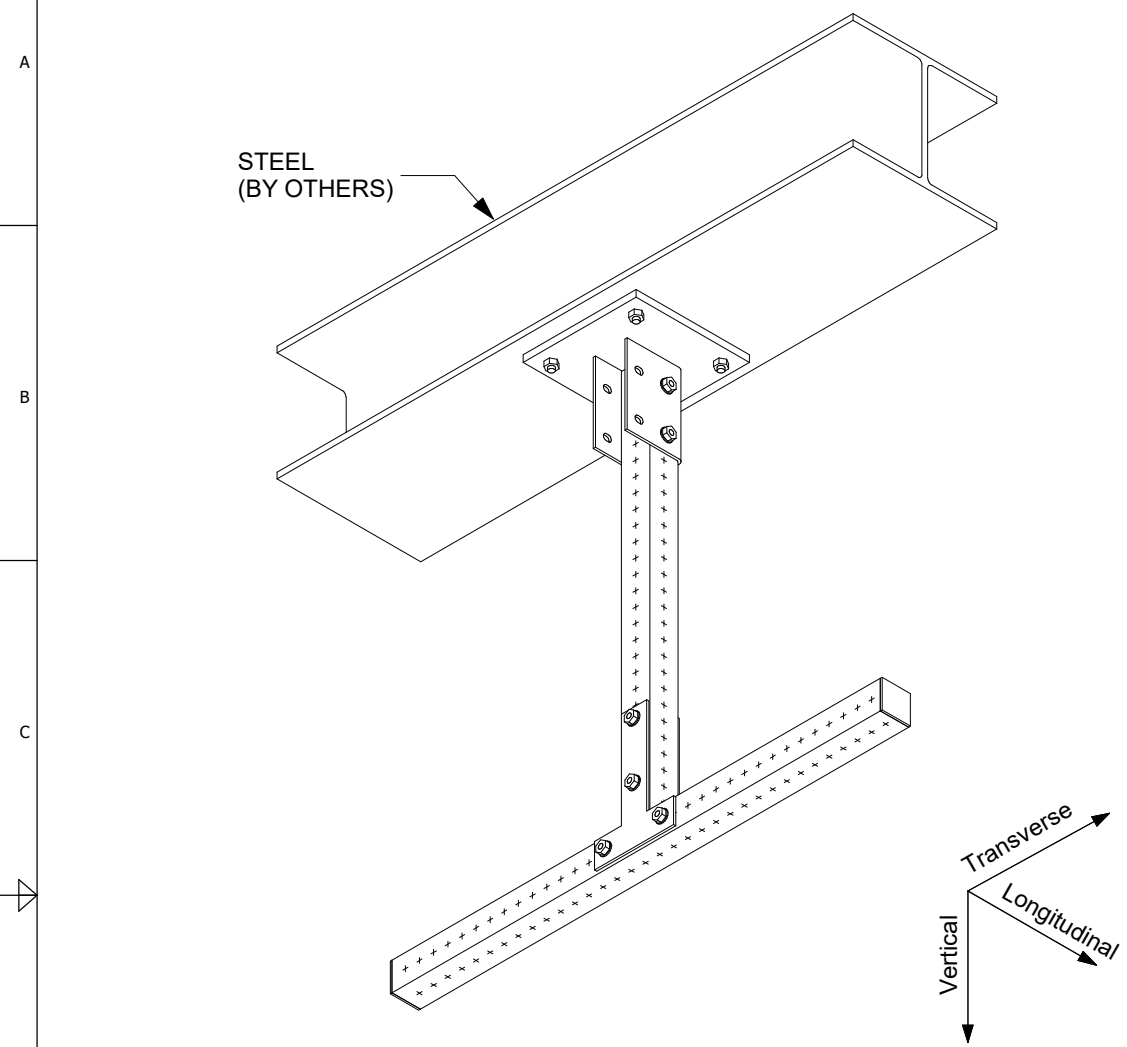

1 ISOMETRIC
N.T.S.

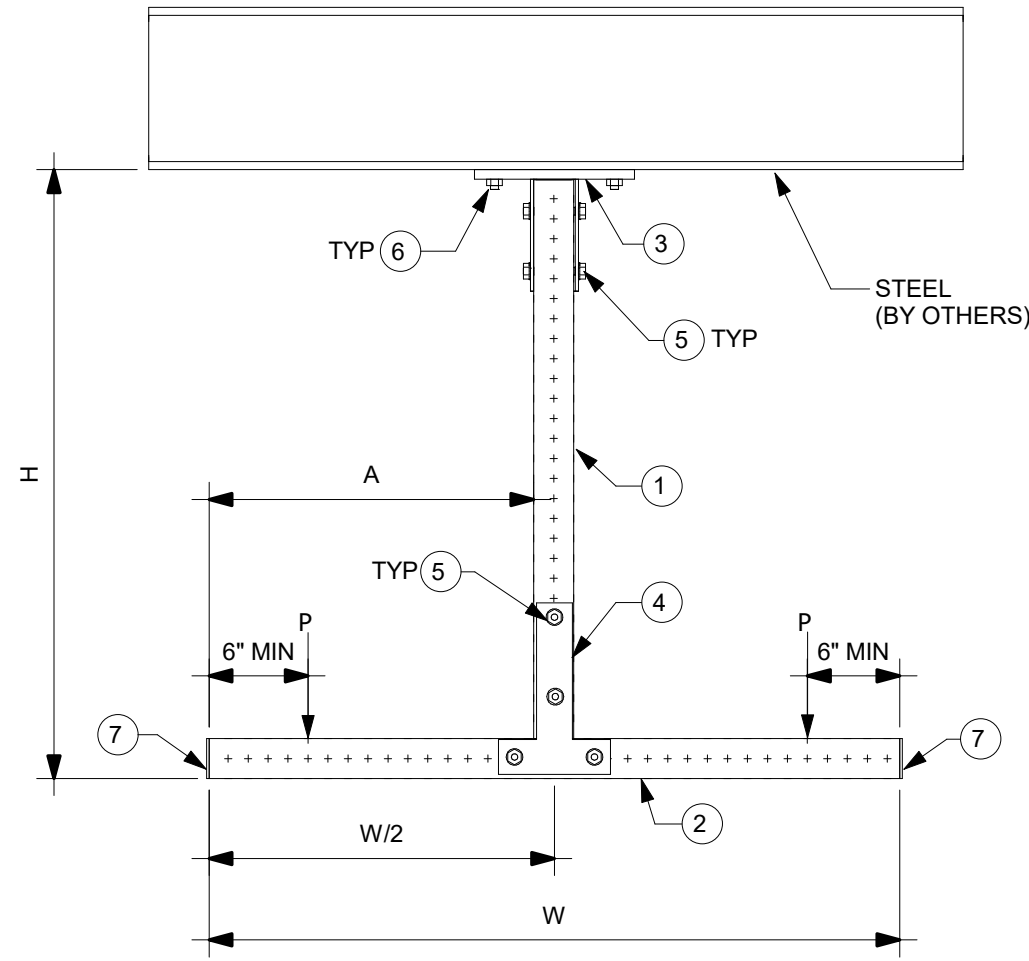

2 ELEVATION
N.T.S.

NOTE(S):

A. THE TYPICAL SUPPORT IS LOAD RATED AND DIMENSIONALLY LIMITED BASED ON DESIGN METHODOLOGY AND GENERIC NON-PROJECT SPECIFIC ASSUMPTIONS SET FORTH IN PROFIS MODULAR SUPPORTS ENGINEERING SOFTWARE VERSION 1.3. THE ENGINEER OF RECORD SHALL EVALUATE THIS TYPICAL SUPPORT TO DETERMINE ITS SUITABILITY FOR THE ACTUAL PROJECT SPECIFIC DESIGN CRITERIA AND REQUIREMENTS.

B. THE EVALUATION OF EXISTING STRUCTURE IS OUTSIDE OF THE TYPICAL DESIGN SCOPE AND SHALL BE PERFORMED BY THE ENGINEER OF RECORD.

C. TYPICAL SUPPORT DESIGN IS BASED ON INTERNATIONAL BUILDING CODE (IBC) 2018. SEE TABLE-A FOR ALLOWABLE STRENGTH DESIGN LOADS (STATIC U.N.O.); GOVERNING LATERAL LOADS NOTED IN THE ALLOWABLE LOAD TABLE IS MAXIMUM OF 30% OF DEAD LOAD.

D. ALL LOADS ASSUMED TO ACT ON THE SUPPORT, NO ECCENTRICITY CONSIDERED.

E. MAXIMUM ALLOWABLE LOADS NOTED IN TABLE-A ARE BASED ON THE GOVERNING COMBINATION OF VERTICAL LOAD WITH TRANSVERSE LOAD OR VERTICAL LOAD WITH LONGITUDINAL LOAD EQUAL DISTANCE FROM END. A SEPARATE ANALYSIS MUST BE PERFORMED WHEN TRANSVERSE AND LONGITUDINAL LOAD OCCURS SIMULTANEOUSLY.

F. REFER TO HILTI INSTRUCTION FOR USE SHEET FOR REQUIRED INSTALLATION INFORMATION. THREAD FORMING BOLT MAY BE INSTALLED USING A TORQUE WRENCH OR SI-AT-A22 PER INSTRUCTION FOR USE.

G. X-BT REQUIREMENT: MIN. STEEL BASE MATERIAL THICKNESS SHALL BE 5/16". MIN EDGE DISTANCE SHALL BE 3/8". MIN YIELD STRENGTH OF STEEL SHALL BE $F_y=36KSI$.

H. MINIMUM 8" FLANGE WIDTH REQUIRED.

I. LOADS ASSUMED TO BE LOCATED SYMMETRICALLY ON THE SUPPORT.

	24	36	48
Max H, in	24	36	48
Max W, in	24	36	48
Max A, in	11-1/16	17-1/16	23-1/16
Vertical (P)	350	160	90
Transverse	105	48	27
Longitudinal	105	48	27

ALLOWABLE LOADS, lbs

REVISION HISTORY		
NO:	DESCRIPTION:	DATE:
A	ISSUE FOR REVIEW	09/21/2020
B	ISSUE FOR REVIEW	12/14/2020
C	ISSUE FOR REVIEW - NOTE MODIFICATIONS AND DIM CALLOUTS	05/28/2021

PROJECT NAME: T POST MT70 S 001

PROJECT DESCRIPTION: T POST MT70 S 001



DRAWN:	CHECKED:	DESIGNED:	REVIEWED:
GAB	IDP	JDR	BVD
PAPER SIZE: ANSI B		PROJECT NUMBER: TP7S1 - 1	

1 2 3 4 5 6 7 8

1 2 3 4 5 6 7 8

STEEL
(BY OTHERS)

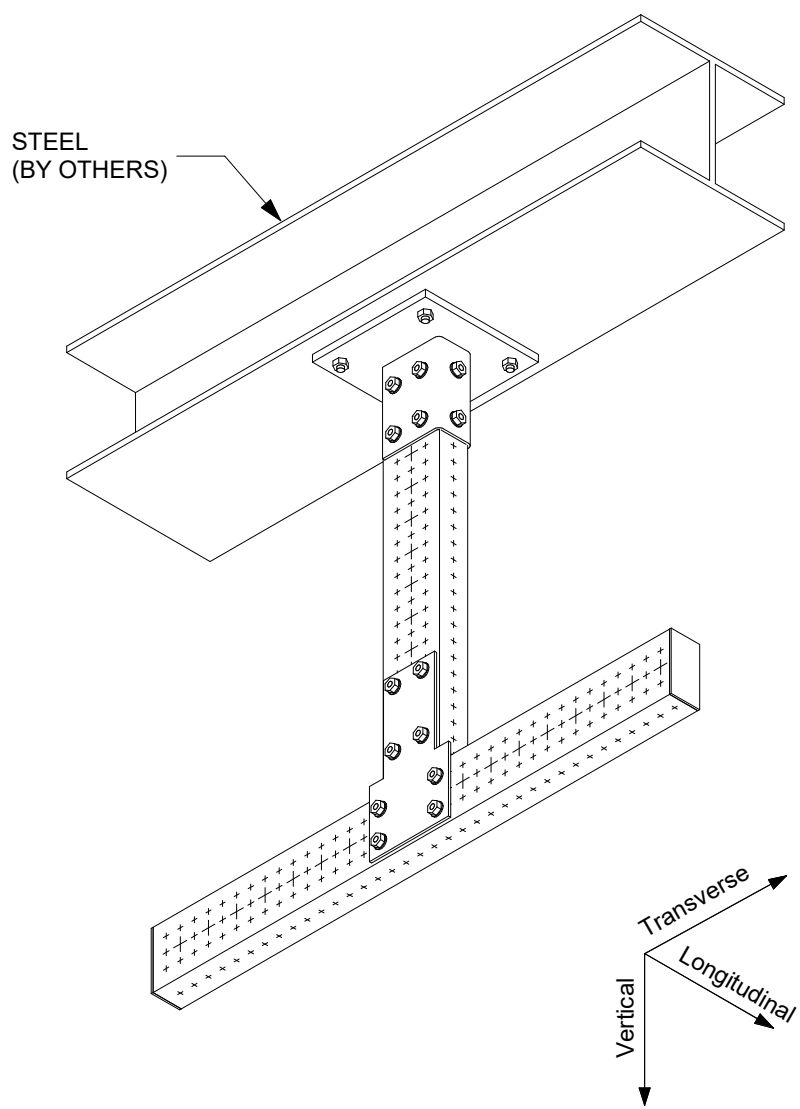

1 ISOMETRIC
N.T.S.

STEEL
(BY OTHERS)

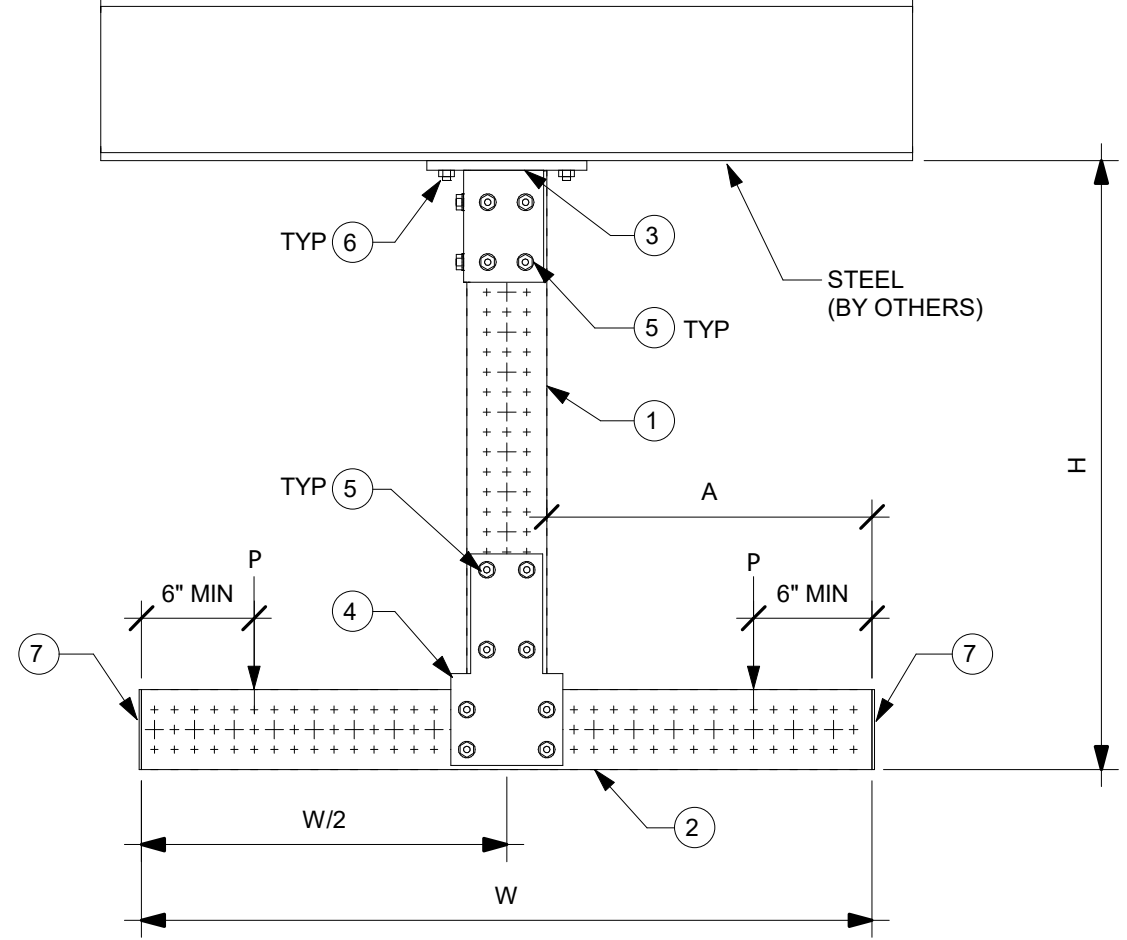

2 ELEVATION
N.T.S.

MARK	ITEM NO.	DESCRIPTION	QTY.
1	2268367	MT-80 OC	1
2	2268367	MT-80 OC	1
3	2272101	MT-B-GS O4U OC	1
4	2272075	MT-C-GLP T OC	2
5	2272084	MT-TFB OC	26
6	2194341	X-BT-MR W10/15 SN 8	4
7	2273698	MT-EC-80	2

NOTE(S):

A. THE TYPICAL SUPPORT IS LOAD RATED AND DIMENSIONALLY LIMITED BASED ON DESIGN METHODOLOGY AND GENERIC NON-PROJECT SPECIFIC ASSUMPTIONS SET FORTH IN PROFIS MODULAR SUPPORTS ENGINEERING SOFTWARE VERSION 1.5. THE ENGINEER OF RECORD SHALL EVALUATE THIS TYPICAL SUPPORT TO DETERMINE ITS SUITABILITY FOR THE ACTUAL PROJECT SPECIFIC DESIGN CRITERIA AND REQUIREMENTS.

B. THE EVALUATION OF EXISTING STRUCTURE IS OUTSIDE OF THE TYPICAL DESIGN SCOPE AND SHALL BE PERFORMED BY THE ENGINEER OF RECORD.

C. TYPICAL SUPPORT DESIGN IS BASED ON INTERNATIONAL BUILDING CODE (IBC) 2018. SEE TABLE-A FOR ALLOWABLE STRENGTH DESIGN LOADS (STATIC U.N.O.); GOVERNING LATERAL LOADS NOTED IN THE ALLOWABLE LOAD TABLE IS MAXIMUM OF 30% OF DEAD LOAD.

D. ALL LOADS ASSUMED TO ACT ON THE SUPPORT, NO ECCENTRICITY CONSIDERED.

E. MAXIMUM ALLOWABLE LOADS NOTED IN TABLE-A ARE BASED ON THE GOVERNING COMBINATION OF VERTICAL LOAD WITH TRANSVERSE LOAD OR VERTICAL LOAD WITH LONGITUDINAL LOAD EQUAL DISTANCE FROM END. A SEPARATE ANALYSIS MUST BE PERFORMED WHEN TRANSVERSE AND LONGITUDINAL LOAD OCCURS SIMULTANEOUSLY.

F. REFER TO HILTI INSTRUCTION FOR USE SHEET FOR REQUIRED INSTALLATION INFORMATION. THREAD FORMING BOLT MAY BE INSTALLED USING A TORQUE WRENCH OR SI-AT-A22 PER INSTRUCTION FOR USE.

G. X-BT REQUIREMENT: MIN. STEEL BASE MATERIAL THICKNESS SHALL BE 5/16". MIN EDGE DISTANCE SHALL BE 3/8". MIN YIELD STRENGTH OF STEEL SHALL BE FY=36KSI.

H. MINIMUM 8" FLANGE WIDTH REQUIRED.

I. LOADS ASSUMED TO BE LOCATED SYMMETRICALLY ON THE SUPPORT.

	24	36	48
Max H, in	24	36	48
Max W, in	24	36	48
Max A, in	10-1/16	16-1/16	22-1/16
Vertical (P)	425	300	240
Transverse	127	90	72
Longitudinal	127	90	72

ALLOWABLE
LOADS, lbs

REVISION HISTORY			
NO:	DESCRIPTION:	DATE:	
A	ISSUE FOR REVIEW	09/21/2020	
B	ISSUE FOR REVIEW	12/14/2020	
C	ISSUE FOR REVIEW - NOTE MODIFICATIONS AND DIM CALLOUTS	05/28/2021	

PROJECT NAME:
T POST MT80 S 001

PROJECT DESCRIPTION:
T POST MT80 S 001

DRAWN:	CHECKED:	DESIGNED:	REVIEWED:
MDH	IDP	JDR	BVD
PAPER SIZE: ANSI B		PROJECT NUMBER: - TP8S1 - 1	

MARK	ITEM NO.	DESCRIPTION	QTY.
1	2268367	MT-80 OC	1
2	2268367	MT-80 OC	1
3	2272101	MT-B-GS O4U OC	1
4	2272075	MT-C-GLP T OC	2
5	2272084	MT-TFB OC	26
6	2210261	ANCHOR KB-TZ2 1/2" x 4-1/2" SS304	4
7	2273698	MT-EC-80	2

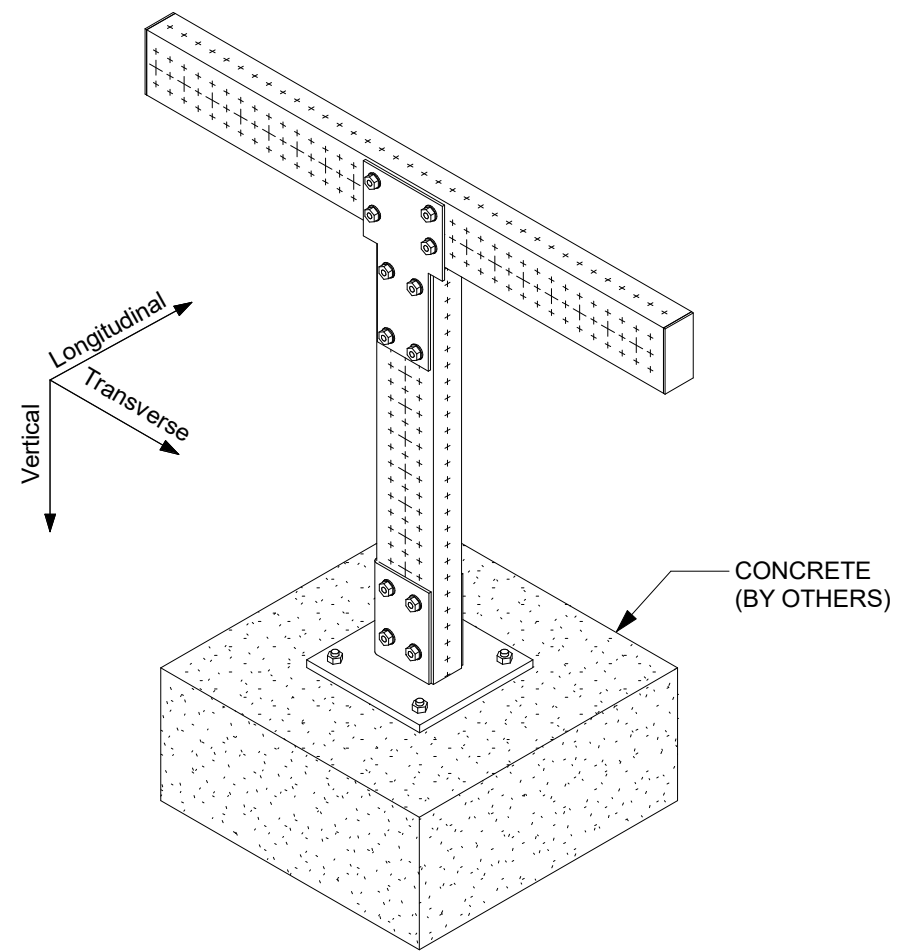

1 ISOMETRIC
N.T.S.

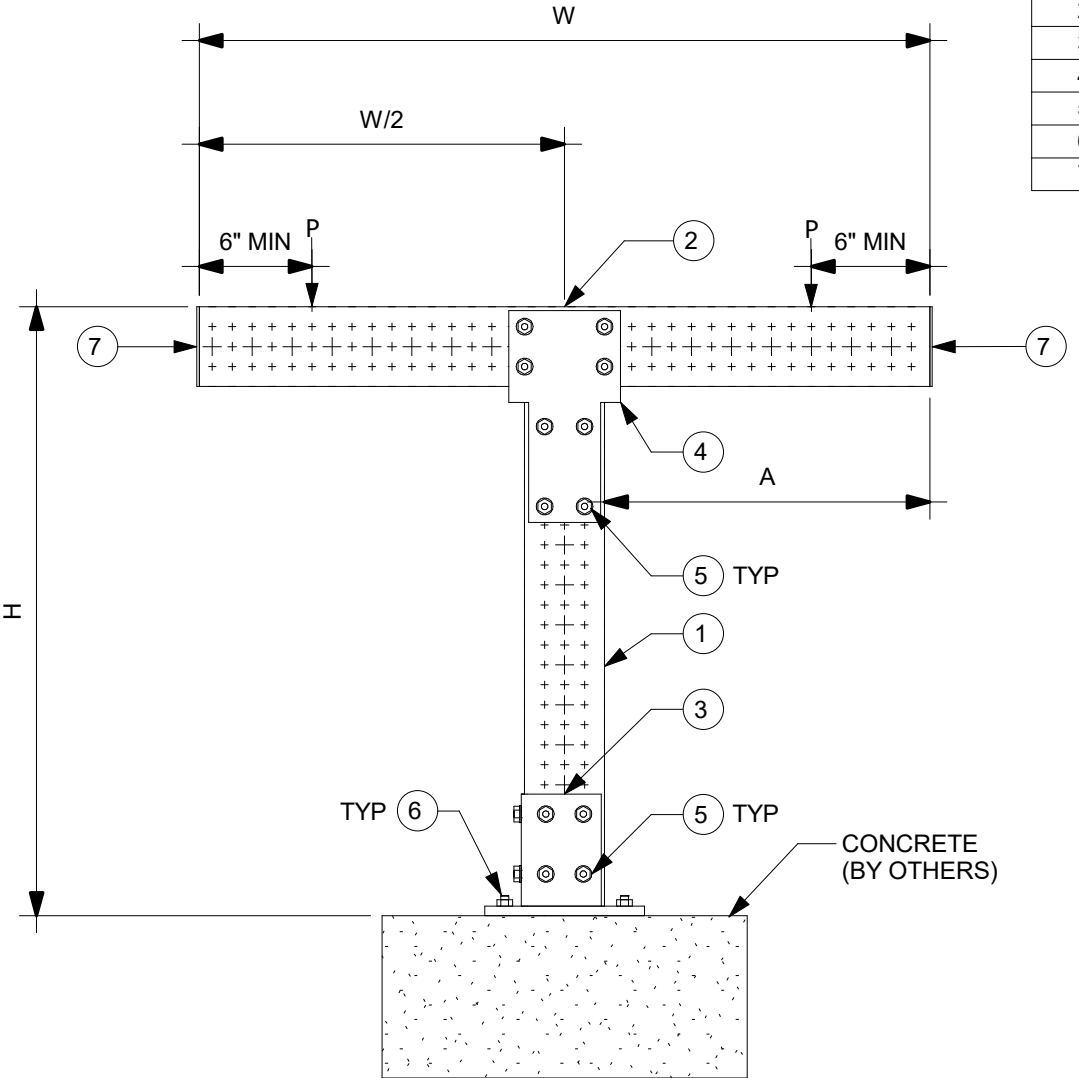

2 ELEVATION
N.T.S.

NOTE(S):

A. THE TYPICAL SUPPORT IS LOAD RATED AND DIMENSIONALLY LIMITED BASED ON DESIGN METHODOLOGY AND GENERIC NON-PROJECT SPECIFIC ASSUMPTIONS SET FORTH IN PROFIS MODULAR SUPPORTS ENGINEERING SOFTWARE VERSION 1.3. THE ENGINEER OF RECORD SHALL EVALUATE THIS TYPICAL SUPPORT TO DETERMINE ITS SUITABILITY FOR THE ACTUAL PROJECT SPECIFIC DESIGN CRITERIA AND REQUIREMENTS.

B. THE EVALUATION OF EXISTING STRUCTURE IS OUTSIDE OF THE TYPICAL DESIGN SCOPE AND SHALL BE PERFORMED BY THE ENGINEER OF RECORD.

C. TYPICAL SUPPORT DESIGN IS BASED ON INTERNATIONAL BUILDING CODE (IBC) 2018. SEE TABLE-A FOR ALLOWABLE STRENGTH DESIGN LOADS (STATIC U.N.O.); GOVERNING LATERAL LOADS NOTED IN THE ALLOWABLE LOAD TABLE IS MAXIMUM OF 30% OF DEAD LOAD.

D. ALL LOADS ASSUMED TO ACT ON THE SUPPORT, NO ECCENTRICITY CONSIDERED

E. MAXIMUM ALLOWABLE LOADS NOTED IN TABLE-A ARE BASED ON THE GOVERNING COMBINATION OF VERTICAL LOAD WITH TRANSVERSE LOAD OR VERTICAL LOAD WITH LONGITUDINAL LOAD EQUAL DISTANCE FROM END. A SEPARATE ANALYSIS MUST BE PERFORMED WHEN TRANSVERSE AND LONGITUDINAL LOAD OCCURS SIMULTANEOUSLY.

F. REFER TO HILTI INSTRUCTION FOR USE SHEET FOR REQUIRED INSTALLATION INFORMATION.

G. SEE BOM FOR KWIK BOLT-TZ2 ANCHOR BOLT. FOR 1/2" DIA. HILTI KWIK BOLT-TZ2 USE MIN. 3-1/4" EFFECTIVE EMBEDMENT. FOR 5/8" DIA. KWIK BOLT-TZ2 USE 3-1/4" MIN. EFFECTIVE EMBEDMENT. INSTALL ANCHOR PER ESR-4266 AND HILTI'S INSTRUCTIONS FOR USE AND RECOMMENDATIONS. MIN. CONCRETE COMPRESSIVE STRENGTH FC=3000 PSI, MIN. CONCRETE EDGE DISTANCE = 6", AND MIN. CONCRETE THICKNESS = 6".

H. CONCRETE ANCHORS NOTED IN THE BILL OF MATERIAL ARE DESIGNED ONLY FOR WIND LATERAL LOADING. ENGINEER OF RECORD TO VERIFY ADEQUACY OF ANCHOR WHEN TYPICAL IS BEING USED FOR SEISMIC LATERAL LOADING.

I. LOADS ASSUMED TO BE LOCATED SYMMETRICALLY ON THE SUPPORT.

	24	36	48
Max H, in	24	36	48
Max W, in	24	36	48
Max A, in	10-1/16	16-1/16	22-1/16
Vertical (P)	925	420	240
Transverse	278	126	72
Longitudinal	278	126	72

ALLOWABLE LOADS, lbs

REVISION HISTORY		
NO.	DESCRIPTION:	DATE:
B	NOTE MODIFICATIONS	01/29/2021
C	ISSUE FOR BU USE	07/06/2021
D	ANCHOR NOTE AND BOM MODIFICATION FOR ANCHOR	03/22/2022

PROJECT NAME: T POST MT80 C 001



PROJECT DESCRIPTION: T POST MT80 C 001

DRAWN:	CHECKED:	DESIGNED:	REVIEWED:
GAB	IDP	JDR	BVD
PAPER SIZE:	PROJECT NUMBER:		
ANSI B	PROJECT	JOB	SHEET
	- TP8C1 -		1

1 2 3 4 5 6 7 8

MARK	ITEM NO.	DESCRIPTION	QTY.
1	2268367	MT-80 OC	1
2	2268367	MT-80 OC	1
3	2272101	MT-B-GS O4U OC	1
4	2272075	MT-C-GLP T OC	2
5	2272084	MT-TFB OC	26
6	2194341	X-BT-MR W10/15 SN 8	4
7	2273698	MT-EC-80	2

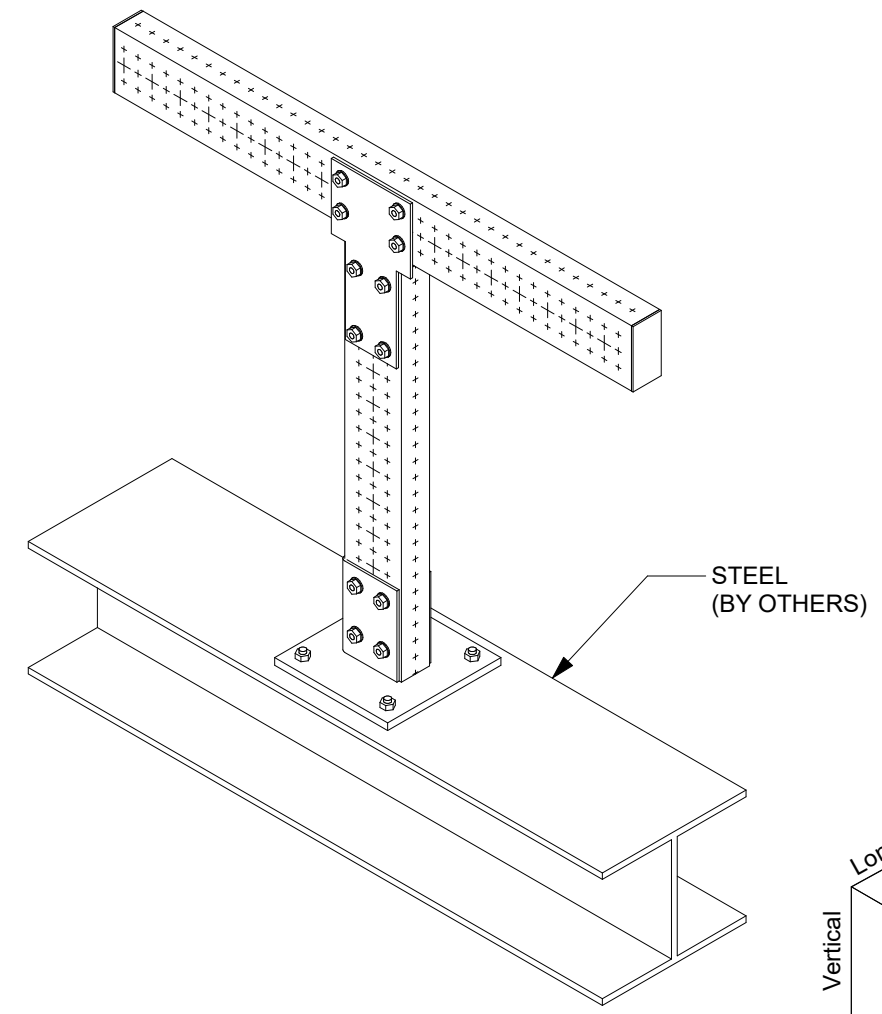

1 ISOMETRIC
N.T.S.

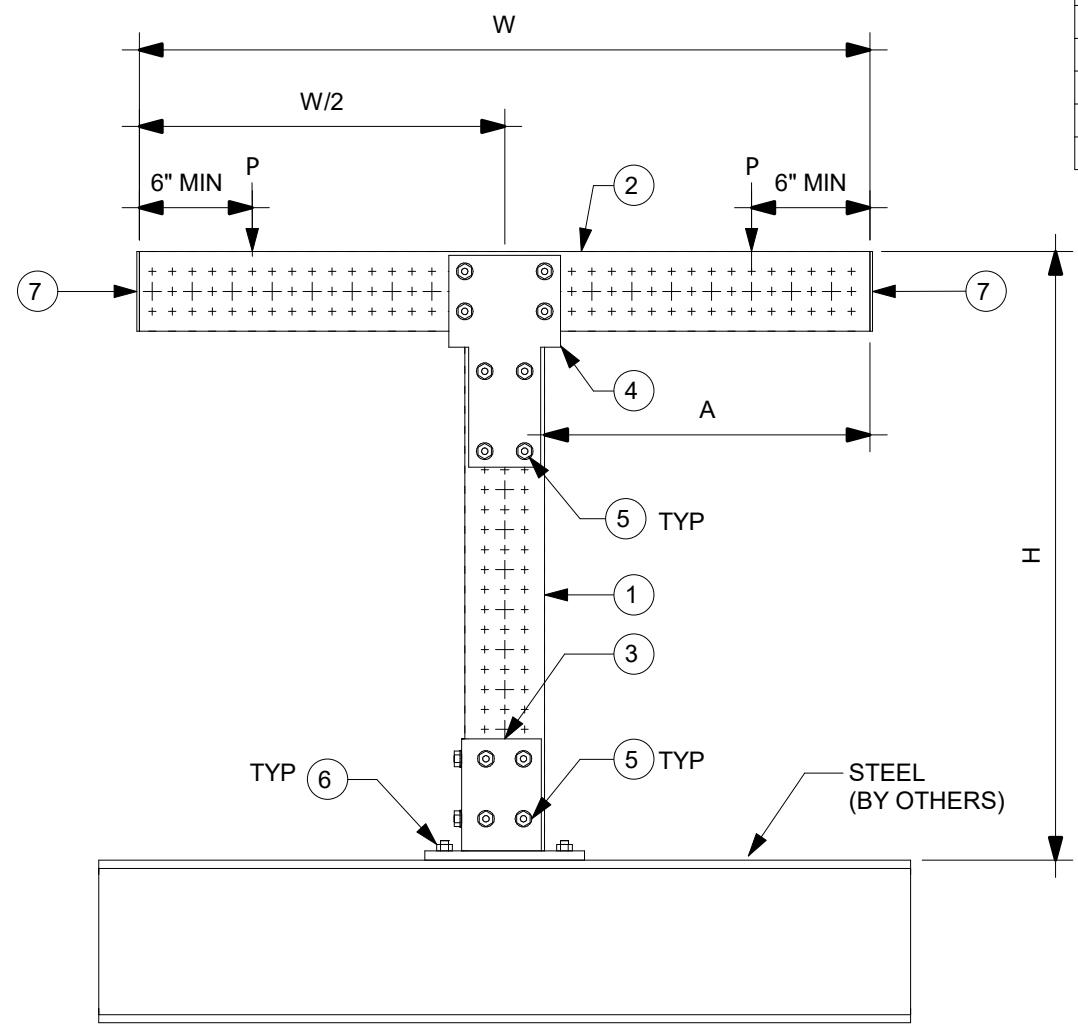

2 ELEVATION
N.T.S.

NOTE(S):

A. THE TYPICAL SUPPORT IS LOAD RATED AND DIMENSIONALLY LIMITED BASED ON DESIGN METHODOLOGY AND GENERIC NON-PROJECT SPECIFIC ASSUMPTIONS SET FORTH IN PROFIS MODULAR SUPPORTS ENGINEERING SOFTWARE VERSION 1.5. THE ENGINEER OF RECORD SHALL EVALUATE THIS TYPICAL SUPPORT TO DETERMINE ITS SUITABILITY FOR THE ACTUAL PROJECT SPECIFIC DESIGN CRITERIA AND REQUIREMENTS.

B. THE EVALUATION OF EXISTING STRUCTURE IS OUTSIDE OF THE TYPICAL DESIGN SCOPE AND SHALL BE PERFORMED BY THE ENGINEER OF RECORD.

C. TYPICAL SUPPORT DESIGN IS BASED ON INTERNATIONAL BUILDING CODE (IBC) 2018. SEE TABLE-A FOR ALLOWABLE STRENGTH DESIGN LOADS (STATIC U.N.O.); GOVERNING LATERAL LOADS NOTED IN THE ALLOWABLE LOAD TABLE IS MAXIMUM OF 30% OF DEAD LOAD.

D. ALL LOADS ASSUMED TO ACT ON THE SUPPORT, NO ECCENTRICITY CONSIDERED.

E. MAXIMUM ALLOWABLE LOADS NOTED IN TABLE-A ARE BASED ON THE GOVERNING COMBINATION OF VERTICAL LOAD WITH TRANSVERSE LOAD OR VERTICAL LOAD WITH LONGITUDINAL LOAD EQUAL DISTANCE FROM END. A SEPARATE ANALYSIS MUST BE PERFORMED WHEN TRANSVERSE AND LONGITUDINAL LOAD OCCURS SIMULTANEOUSLY.

F. REFER TO HILTI INSTRUCTION FOR USE SHEET FOR REQUIRED INSTALLATION INFORMATION. THREAD FORMING BOLT MAY BE INSTALLED USING A TORQUE WRENCH OR SI-AT-A22 PER INSTRUCTION FOR USE.

G. X-BT REQUIREMENT: MIN. STEEL BASE MATERIAL THICKNESS SHALL BE 5/16". MIN EDGE DISTANCE SHALL BE 3/8". MIN YIELD STRENGTH OF STEEL SHALL BE FY=36KSI.

H. MINIMUM 8" FLANGE WIDTH REQUIRED.

I. LOADS ASSUMED TO BE LOCATED SYMMETRICALLY ON THE SUPPORT.

	24	36	48
Max H, in	24	36	48
Max W, in	24	36	48
Max A, in	10-1/16	16-1/16	22-1/16
Vertical (P)	925	425	240
Transverse	278	127	72
Longitudinal	278	127	72

ALLOWABLE LOADS, lbs

REVISION HISTORY			
NO:	DESCRIPTION:	DATE:	
A	ISSUE FOR REVIEW	09/21/2020	
B	ISSUE FOR REVIEW	12/14/2020	
C	ISSUE FOR REVIEW - NOTE MODIFICATIONS AND DIM CALLOUTS	05/28/2021	

PROJECT NAME: T POST MT80 S 002

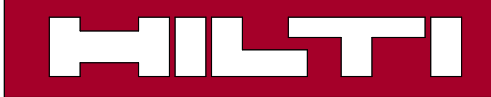

DRAWN:	CHECKED:	DESIGNED:	REVIEWED:
MDH	IDP	JDR	BVD

PAPER SIZE: ANSI B

PROJECT NUMBER:		
PROJECT	JOB	SHEET
- TP8S2 -		1

1 2 3 4 5 6 7 8

MARK	ITEM NO.	DESCRIPTION	QTY.
1	2268369	MT-90 OC	1
2	2268369	MT-90 OC	1
3	2272103	MT-B-GL-O4 OC	1
4	2272075	MT-C-GLP T OC	2
5	2272084	MT-TFB OC	40
6	2210278	ANCHOR KB-TZ2 5/8" X 4-3/4" SS304	4
7	2273699	MT-EC-90	2

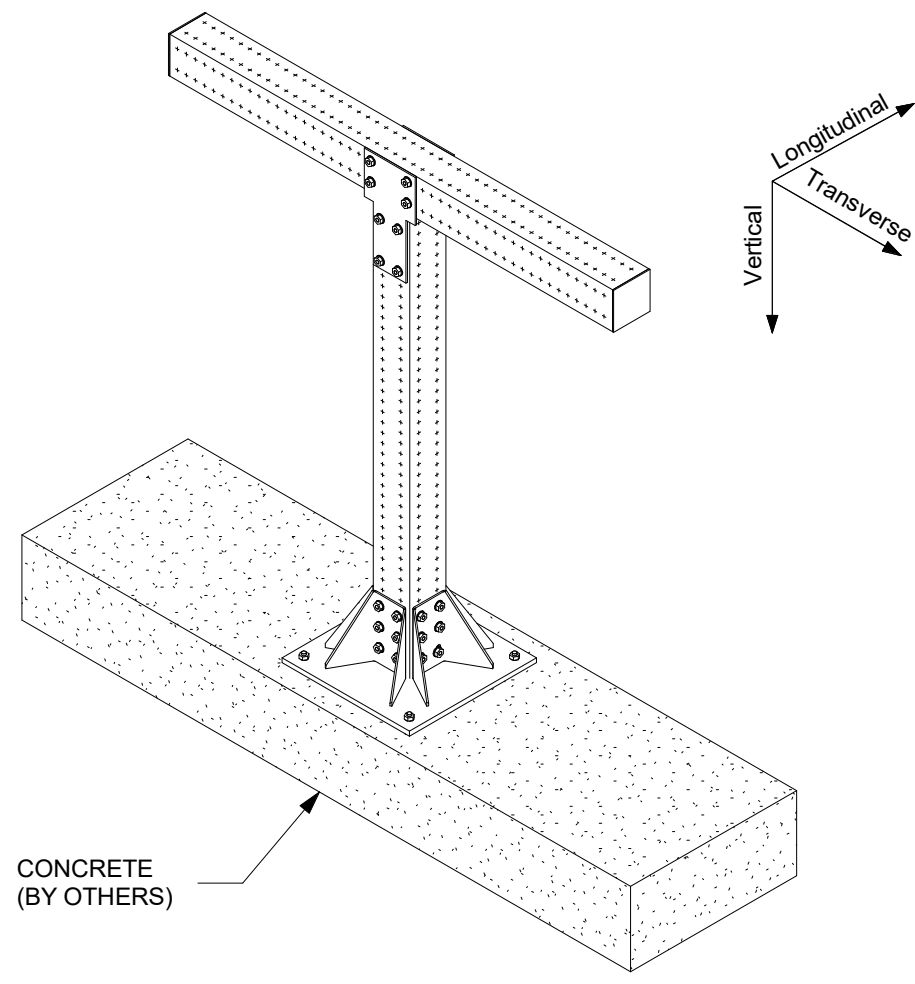

1 ISOMETRIC
N.T.S.

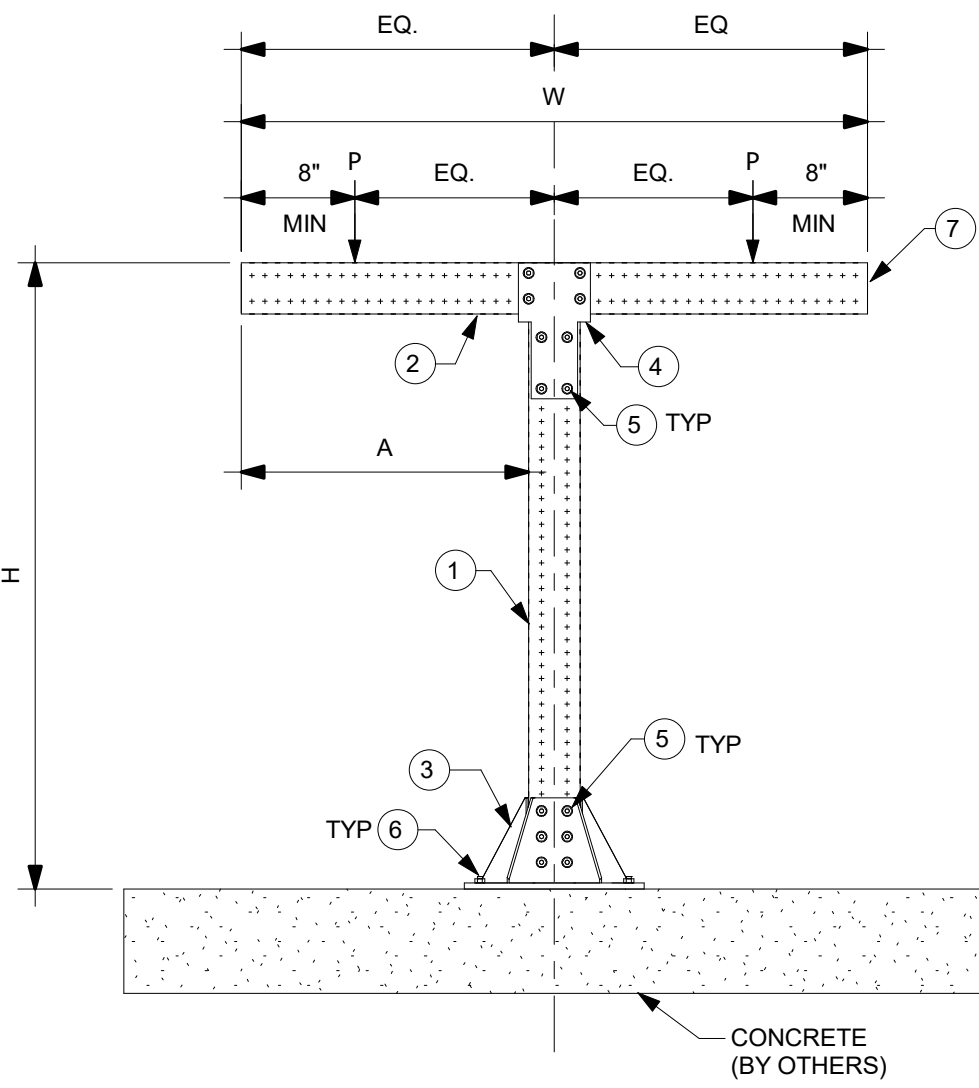

2 ELEVATION
N.T.S.

NOTE(S):

A. THE TYPICAL SUPPORT IS LOAD RATED AND DIMENSIONALLY LIMITED BASED ON DESIGN METHODOLOGY AND GENERIC NON-PROJECT SPECIFIC ASSUMPTIONS SET FORTH IN PROFIS MODULAR SUPPORTS ENGINEERING SOFTWARE VERSION 1.3. THE ENGINEER OF RECORD SHALL EVALUATE THIS TYPICAL SUPPORT TO DETERMINE ITS SUITABILITY FOR THE ACTUAL PROJECT SPECIFIC DESIGN CRITERIA AND REQUIREMENTS.

B. THE EVALUATION OF EXISTING STRUCTURE IS OUTSIDE OF THE TYPICAL DESIGN SCOPE AND SHALL BE PERFORMED BY THE ENGINEER OF RECORD.

C. TYPICAL SUPPORT DESIGN IS BASED ON INTERNATIONAL BUILDING CODE (IBC) 2018. SEE TABLE-A FOR ALLOWABLE STRENGTH DESIGN LOADS (STATIC U.N.O.); GOVERNING LATERAL LOADS NOTED IN THE ALLOWABLE LOAD TABLE IS MAXIMUM OF 30% OF DEAD LOAD.

D. ALL LOADS ASSUMED TO ACT ON THE SUPPORT, NO ECCENTRICITY CONSIDERED

E. MAXIMUM ALLOWABLE LOADS NOTED IN TABLE-A ARE BASED ON THE GOVERNING COMBINATION OF VERTICAL LOAD WITH TRANSVERSE LOAD OR VERTICAL LOAD WITH LONGITUDINAL LOAD. A SEPARATE ANALYSIS MUST BE PERFORMED WHEN TRANSVERSE AND LONGITUDINAL LOAD OCCURS SIMULTANEOUSLY.

F. REFER TO HILTI INSTRUCTION FOR USE SHEET FOR REQUIRED INSTALLATION INFORMATION. THREAD FORMING BOLT MAY BE INSTALLED USING A TORQUE WRENCH OR SI-AT-A22 PER INSTRUCTION FOR USE.

G. SEE BOM FOR KWIK BOLT-TZ2 ANCHOR BOLT. FOR 1/2" DIA. HILTI KWIK BOLT-TZ2 USE MIN. 3-1/4" EFFECTIVE EMBEDMENT. FOR 5/8" DIA. KWIK BOLT-TZ2 USE 3-1/4" MIN. EFFECTIVE EMBEDMENT. INSTALL ANCHOR PER ESR-4266 AND HILTI'S INSTRUCTIONS FOR USE AND RECOMMENDATIONS. MIN. CONCRETE COMPRESSIVE STRENGTH F'C=3000 PSI, MIN. CONCRETE EDGE DISTANCE = 6", AND MIN. CONCRETE THICKNESS = 6".

H. CONCRETE ANCHORS NOTED IN THE BILL OF MATERIAL ARE DESIGNED ONLY FOR WIND LATERAL LOADING. ENGINEER OF RECORD TO VERIFY ADEQUACY OF ANCHOR WHEN TYPICAL IS BEING USED FOR SEISMIC LATERAL LOADING.

I. LOADS ASSUMED TO BE LOCATED SYMMETRICALLY ON THE SUPPORT.

	60	72	84
Max H, in	60	72	84
Max W, in	60	72	84
Max A, in	28-1/16	34-1/16	40-1/16
Vertical (P)	600	425	325
Transverse	180	127	97
Longitudinal	180	127	97

ALLOWABLE LOADS, lbs

REVISION HISTORY			
NO.	DESCRIPTION:	DATE:	
B	NOTE MODIFICATIONS	01/29/2021	
C	ISSUE FOR BU USE	07/06/2021	
D	ANCHOR NOTE AND BOM MODIFICATION FOR ANCHOR	03/22/2022	

PROJECT NAME: T POST MT90 C 001

PROJECT DESCRIPTION: T POST MT90 C 001

HILTI			
DRAWN:	CHECKED:	DESIGNED:	REVIEWED:
GAB	IDP	JDR	BVD
PAPER SIZE: ANSI B		PROJECT NUMBER: - TP9C1 - 1	

MARK	ITEM NO.	DESCRIPTION	QTY.
1	2268369	MT-90 OC	1
2	2273589	MT-BC-GXL T OC	4
3	2273699	MT-EC-90	2

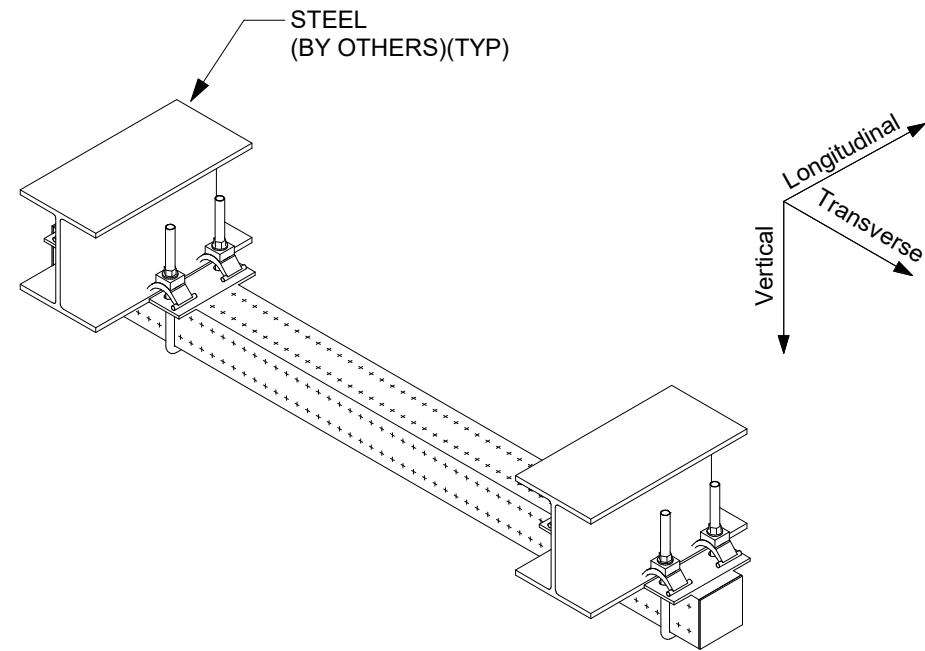

1 ISOMETRIC
N.T.S.

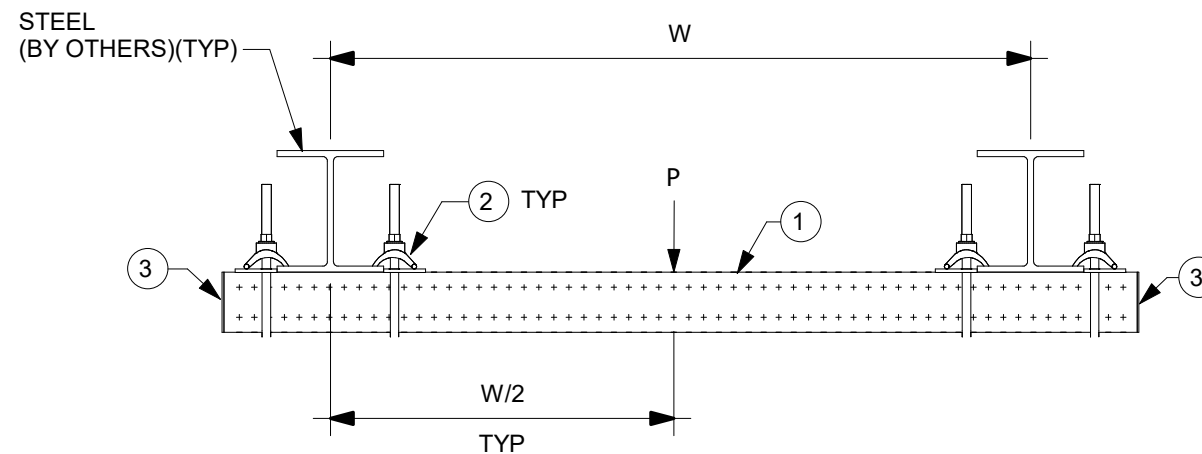

2 ELEVATION
N.T.S.

NOTE(S):

A. THE TYPICAL SUPPORT IS LOAD RATED AND DIMENSIONALLY LIMITED BASED ON DESIGN METHODOLOGY AND GENERIC NON-PROJECT SPECIFIC ASSUMPTIONS SET FORTH IN PROFIS MODULAR SUPPORTS ENGINEERING SOFTWARE VERSION 1.3. THE ENGINEER OF RECORD SHALL EVALUATE THIS TYPICAL SUPPORT TO DETERMINE ITS SUITABILITY FOR THE ACTUAL PROJECT SPECIFIC DESIGN CRITERIA AND REQUIREMENTS.

B. THE EVALUATION OF EXISTING STRUCTURE IS OUTSIDE OF THE TYPICAL DESIGN SCOPE AND SHALL BE PERFORMED BY THE ENGINEER OF RECORD.

C. TYPICAL SUPPORT DESIGN IS BASED ON INTERNATIONAL BUILDING CODE (IBC) 2018. SEE TABLE-A FOR ALLOWABLE STRENGTH DESIGN LOADS (STATIC U.N.O.); GOVERNING LATERAL LOADS NOTED IN THE ALLOWABLE LOAD TABLE IS MAXIMUM OF 30% OF DEAD LOAD.

D. ALL LOADS ASSUMED TO ACT ON THE SUPPORT, NO ECCENTRICITY CONSIDERED.

E. MAXIMUM ALLOWABLE LOADS NOTED IN TABLE-A ARE BASED ON THE GOVERNING COMBINATION OF VERTICAL LOAD WITH TRANSVERSE LOAD OR VERTICAL LOAD WITH LONGITUDINAL LOAD. A SEPARATE ANALYSIS MUST BE PERFORMED WHEN TRANSVERSE AND LONGITUDINAL LOAD OCCURS SIMULTANEOUSLY.

		TABLE A	
ALLOWABLE LOADS, lbs	Max W, in	96	192
	Vertical (P)	650	325
	Transverse	195	98
	Longitudinal	195	98

All loading and design criteria supplied by customer is assumed accurate. Only the stated Design Assumptions were considered, and must be verified by the responsible Engineer of Record (EOR). The basis of Hill component and connection design is the published data in the current Hill Technical Guide, including material and cross-section properties, allowable load values, factors of safety, methods of calculation, and limiting factors. The EOR must verify suitability for any specific application, and the capacity of the supportive structure to receive the shown configuration and associated reaction loads. Modification to components and/or design may alter performance and must be evaluated by the EOR.

REVISION HISTORY		
NO:	DESCRIPTION:	DATE:
A	ISSUE FOR REVIEW	01/07/2021
B	NOTE MODIFICATIONS	01/29/2021
C	ISSUE FOR REVIEW - NOTE MODIFICATIONS AND DIM CALLOUTS	05/28/2021

PROJECT NAME: **HILTI**

HEADER BEAM MT90 S 001

DRAWN:	CHECKED:	DESIGNED:	REVIEWED:
GAB	IDP	JDR	BVD

PROJECT DESCRIPTION: HEADER BEAM MT90 S 001

PAPER SIZE:	PROJECT NUMBER:		
ANSI B	PROJECT	JOB	SHEET
	- HB9S1 -		1