

Installation Best Practices for Hilti CFS-CID MD

CFS CID MD is a one-step firestop cast-in sleeve for plastic and metal pipe penetrations through concrete over metal deck slabs. Should a specific installation situation deviate from the 3rd party listing please reach out to the Hilti Fire Protection Engineering team to see if an engineering judgement is possible.

CONTENTS

- Platform (CFS-CID MD PLT W3" & W2") Installation Best Practices.
- Sleeve (CFS-CID MD) Installation Best Practices.
- Guide Sleeve (CFS-CID MD GUI) Installation Best Practices.
- Hole Saw (CFS-CID MD HS) Instructions Best Practices.

TECHNICAL SUPPORT

There will always be situations when a current UL-listed system doesn't accommodate your application. When that happens, bring your questions to the Hilti firestop experts.

To request an Engineering Judgment, please download the Engineering Judgment Request Form at: <https://www.hilti.com/>. Once you have saved the completed file, please send the completed EJ request form to: usfirestopeng@hilti.com.

Platform (CFS-CID MD PLT W3" & W2") Installation and Best Practices

- Ensure the correct platform (CFS-CID MD PLT) is being selected per the project metal deck details.

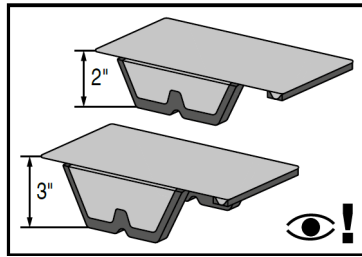

- The platform must be installed so the foam insert can properly seat inside of the top flute joint.

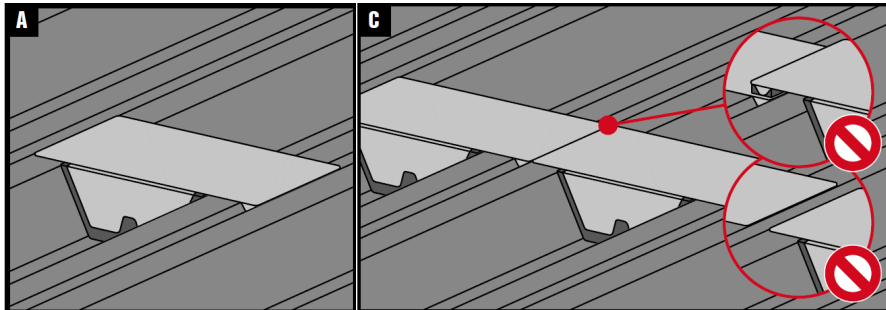

By laying out the platform as explained above, this platform reduces or eliminates the chance of concrete getting in the top flute joint, thereby protecting the sleeve above.

- Incorrectly installed platforms can leave gaps that lead to concrete intrusions. This can create challenges during the drilling step.



When platforms are overlapped a void is created allowing for concrete

- When placing platforms, do not slide into position, as this can lead to damaging the foam seal leading to concrete intrusion. Instead place the platforms straight down and pressing into place.
- Best option for fastening the Platform is to use one 3/4" screw on each corner to ensure the platform is flat with no gaps underneath.

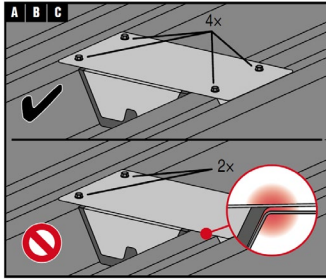

- When running multiple platforms together seal any open seams to minimize risk of concrete intrusions.

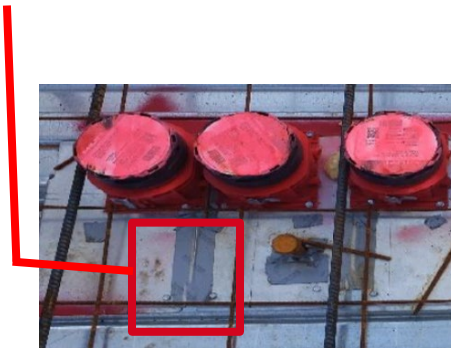
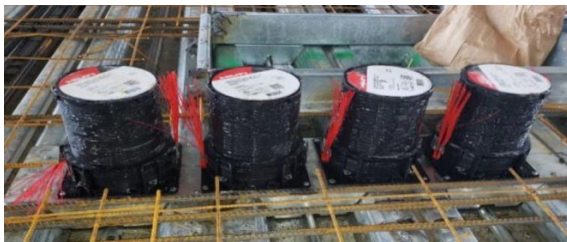

Sleeve (CFS-CID MD) Installation Best Practices

- Best option for fastening the sleeve is to use one ¾" screw on each corner to avoid any gaps underneath. Ensure that sleeves are not sitting on top of screw used to secure the platform.

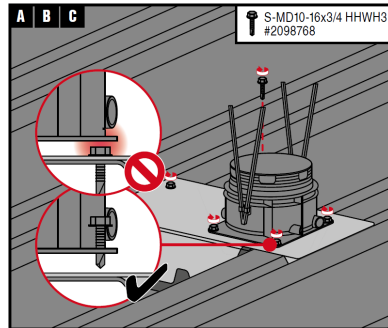

- When a device falls directly on an upper flute, it is highly recommended to still use a platform to avoid any concrete intrusion underneath the sleeve base.



Gaps for concrete intrusion

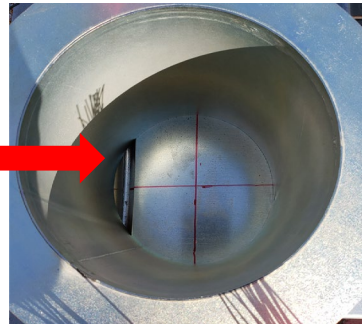

- Ensure the whole device sits within the platform surface, to avoid any concrete intrusion underneath the sleeve base.

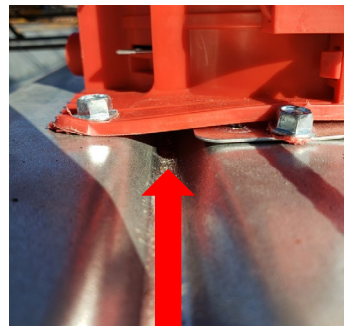

By flipping the platform around so that the foam insert is covering the correct upper flute will help avoid any gap.

- It is recommended to perform a walk-through inspection of installed sleeves to verify that no gaps can be found. If any are found PU foam or tape can be used to fill the void and prevent concrete intrusion.



- Avoid placing a sleeve on top of the seams between two different platforms. This will result in having to cut through extra metal increasing overall cutting time and reducing hole saw lifetime.



Guide Sleeve (CFS-CID MD GUI) Installation Best Practices

- Make sure to select the guide sleeve diameter corresponding to the sleeve diameter.

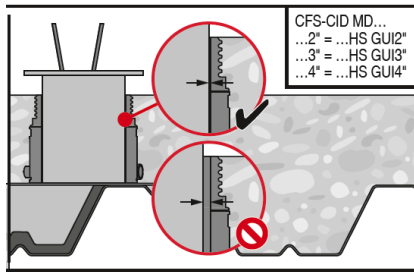

- Push the guide sleeve all the way down to prevent any damage on the firestop inlay and the smoke gasket. This will also better prevent the guide sleeve from spinning during cutting.



- If guide sleeve becomes warped or chipped it must be replaced.

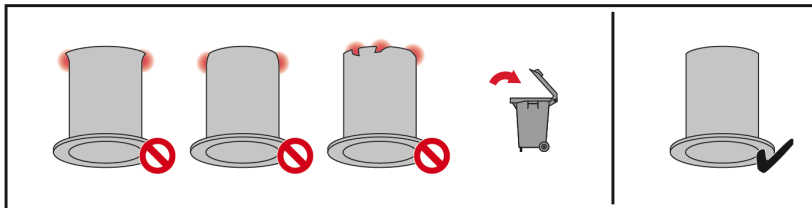

- For Thicker Concrete Slabs 12" long guide sleeves are available, contact your local Hilti rep.
- CFS-CID MD HS GUI 2"X 12" – 3705111
- CFS-CID MD HS GUI 3"X 12" - 3705112
- CFS-CID MD HS GUI 4"X 12" - 3705203



Hole Saw (CFS-CID MD HS) Installation Best Practices

- Prior to Cutting remove all debris from sleeve that could damage the carbides and dramatically reduce the lifetime of the hole saw.



- Before Drilling verify that correct method is selected based upon tool type being used
 - SDS PLUS – Rotary Only
 - SDS MAX- Hammer Drill only
- The arbor for the SDS Max is specifically designed to decouple the hammer action from the shaft. The hammer still activates in the drill but it does not strike the arbor due to the design of the inserted head

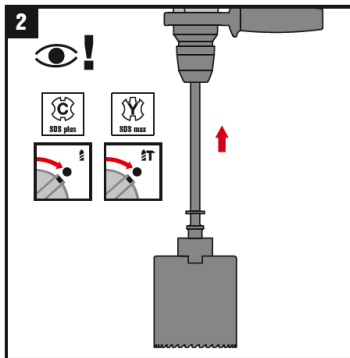

- Ensure hole saw is flat with cutting surface before starting.

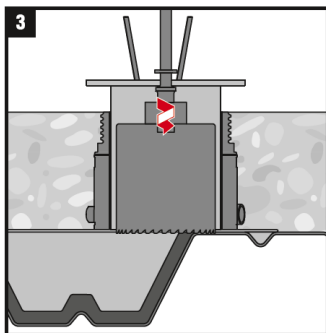

- Once platform has been cut through, take the hole saw out and remove the cut piece before moving forward with deck cutting. Once drilling of metal deck is completed remove hole saw, then guide sleeve.

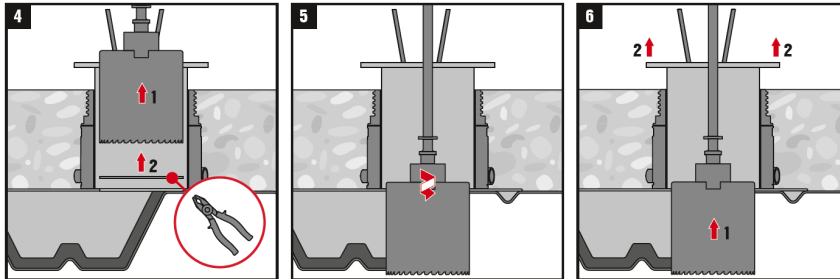

- Tool should be 90 degrees to the slab. Do not add pressure on the tool, the tool will do the job.
- In case the Guide Sleeve would start spinning secure the guide sleeve lips to keep it still.
- Letting the tool and hole saw do the job will make the cutting process smoother and faster. Applying too high of pressure will lead to premature tooth fractures, teeth flaring, and excess heat generation can burn the hole saw.



- Jobsite condition and installer experience will influence drilling time. In normal conditions, tests showed the following average drilling times:

2" - Between 15 – 60 seconds

3" – Between 60 -120 seconds

4" – Between 90 – 180 seconds

- Cutting fluid may be added as an option to extend the lifetime of the holesaw. Apply the cutting fluid by lightly pouring the oil onto a shop towel/rag and rubbing the holesaw with the lubricated shop towel/ rag. Take special caution to wipe excess fluid from the holesaw before inserting through the guide sleeve. The hole saw should not be dripping with cutting fluid.



