

TOP OF WALL JOINT : GYPSUM WALL ASSEMBLY

ASSEMBLY RATING = 1-HR. OR 2-HR.

L-RATING AT AMBIENT = 1 CFM / LIN FT (SEE NOTE NO. 4 BELOW)

L-RATING AT 400°F = LESS THAN 1 CFM / LIN FT (SEE NOTE NO. 4 BELOW)

CLASS II AND III MOVEMENT CAPABILITIES - 62% OR 86% COMPRESSION OR EXTENSION OR 92% COMPRESSION ONLY (SEE TABLE BELOW)

HWD0871g.100724

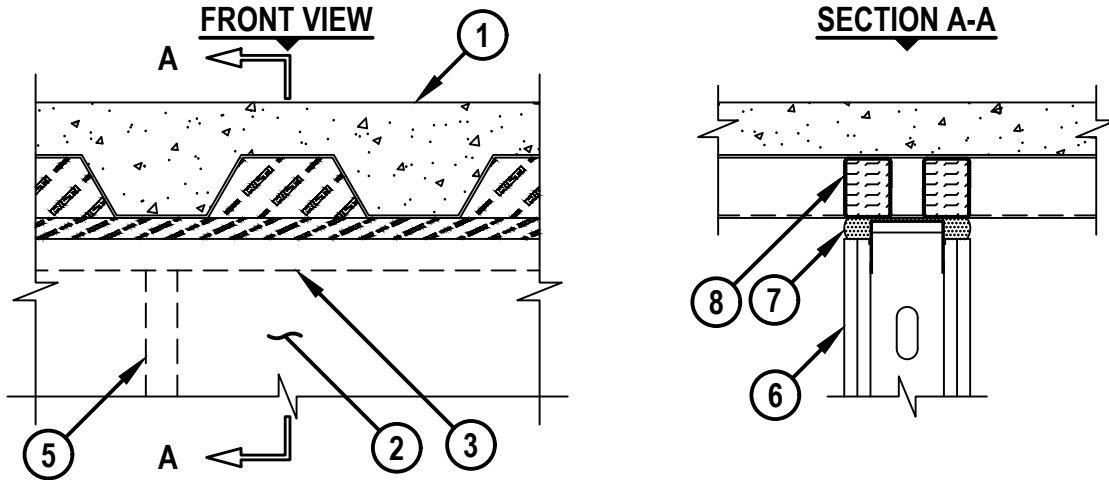

1. LIGHTWEIGHT OR NORMAL WEIGHT CONCRETE FLOOR (MINIMUM 2-1/2" THICK) OVER METAL DECKING ASSEMBLY (UL/cUL CLASSIFIED). THE HOURLY FIRE RATING OF THE FLOOR ASSEMBLY SHALL BE EQUAL TO OR GREATER THAN THE HOURLY RATING OF THE WALL ASSEMBLY.
2. GYPSUM WALL ASSEMBLY (UL/cUL CLASSIFIED U400, V400 OR W400 SERIES) (1-HR. OR 2-HR. FIRE-RATING) (2-HR. SHOWN). THE HOURLY RATING OF THE JOINT SYSTEM IS DEPENDENT UPON THE HOURLY RATING OF THE WALL ASSEMBLY.
3. CEILING RUNNER (MIN. 25 GA., FLANGE HEIGHT OF CEILING RUNNER SHALL BE MINIMUM 1/4" GREATER THAN MAXIMUM EXTENDED JOINT WIDTH) FASTENED TO UNDERSIDE OF FLOOR WITH MASONRY ANCHORS OR STEEL FASTENERS (SPACED MAXIMUM 24" OC) (SEE NOTE NO. 3 BELOW).
4. [OPTIONAL - NOT SHOWN] WHEN SPRAY-APPLIED FIREPROOFING IS USED, CEILING RUNNER MAY BE SECURED TO DECK WITH Z-SHAPED CLIPS (MIN. 20 GA.) WITH THE FOLLOWING DIMENSIONS : MINIMUM 1" LONG, BUT NOT EXCEEDING THE WIDTH OF THE WALL, BY 1-1/2" OR 2" LONG UPPER AND LOWER LEGS. SUPPORT CLIPS SPACED MAXIMUM 24" OC.
5. STEEL STUDS (MIN. 3-1/2" WIDE) CUT 3/4" TO 1" LESS IN LENGTH THAN ASSEMBLY HEIGHT WITH BOTTOM NESTING IN CEILING RUNNER WITHOUT ATTACHMENT.
6. 5/8" OR 1-1/4" THICKNESS GYPSUM WALLBOARD AS SPECIFIED IN THE INDIVIDUAL UL DESIGN. TOP ROW OF SCREWS SHALL BE INSTALLED INTO STUD 3-1/2" TO 5-1/2" BELOW THE BOTTOM EDGE OF THE CEILING RUNNER.
7. HILTI CFS-TTS MD OS OR CFS-TTS MD 600 FIRESTOP TOP TRACK SEAL INSTALLED OVER CEILING RUNNER PRIOR TO ATTACHMENT TO UNDERSIDE OF STEEL FLOOR UNIT IN ACCORDANCE WITH THE ACCOMPANYING INSTALLATION INSTRUCTIONS.



HILTI, Inc.
Plano, Texas USA (800) 879-8000

Sheet	1 of 2
Scale	7/64" = 1"
Date	Oct. 07, 2024

Drawing No.
**HWD
0871g**

TOP OF WALL JOINT : GYPSUM WALL ASSEMBLY

ASSEMBLY RATING = 1-HR. OR 2-HR.

L-RATING AT AMBIENT = 1 CFM / LIN FT (SEE NOTE NO. 4 BELOW)

L-RATING AT 400°F = LESS THAN 1 CFM / LIN FT (SEE NOTE NO. 4 BELOW)

CLASS II AND III MOVEMENT CAPABILITIES - 62% OR 86% COMPRESSION OR EXTENSION OR 92% COMPRESSION ONLY (SEE TABLE BELOW)

HWD0871g.100724

8. HILTI CFS-TTS MD P [1.5, 2, OR 3] FIRESTOP TOP TRACK PLUG (PLUG SIZE TO MATCH DECK HEIGHT) TO BE FRICTION FIT IN FLUTES ABOVE THE CEILING RUNNER FLUSH WITH THE OUTER SURFACE OF THE HILTI CFS-TTS MD TOP TRACK SEAL ON BOTH SIDES OF WALL. WHERE A PARTIAL FLUTE EXISTS, THE FLUTE PLUG CAN BE CUT TO FIT THE PARTIAL FLUTE WITH THE CUT SIDE OF THE FLUTE PLUG SEALED WITH ALUMINUM FOIL TAPE (SEE NOTES NO. 1 AND 2 BELOW).

MAX NOM JOINT WIDTH	MAX MOVEMENT CAPABILITIES		MAX MOVEMENT
7/8"	COMPRESSION	86%	3/4"
	EXTENSION	86%	3/4"
1"	COMPRESSION	62%	5/8"
	EXTENSION	62%	5/8"
1-5/8"	COMPRESSION	92%	1-1/2"
	EXTENSION	0%	0"

AS AN ALTERNATIVE TO THE MOVEMENT PERCENTAGES ABOVE, THE JOINT SYSTEM MAY MOVE FREELY WITHOUT RESTRICTION TO THE PERCENTAGE OF MOVEMENT WITHIN THE RANGE OF A MIN 1/8" TO MAX 1-5/8" JOINT WIDTH.

- NOTES :
1. STEEL FLOOR UNITS MAY BE SPRAYED WITH UL CLASSIFIED MONOKOTE TYPE MK-6/HY OR MK-10HB (MANUFACTURED BY GCP APPLIED TECHNOLOGIES) OR CAFCO TYPE 300 (MANUFACTURED BY ISOLATEK, INT.) FIREPROOFING, PRIOR TO THE INSTALLATION OF THE CEILING RUNNER AND HILTI CFS-TTS MD. WHEN SPRAY-APPLIED FIRE RESISTIVE MATERIAL IS USED IT SHALL COMPLETELY FILL THE FLUTES ABOVE AND EXTENDING THE WIDTH OF THE WALL.
 2. [OPTIONAL] AS AN ALTERNATE TO CFS-TTS MD P FIRESTOP TOP TRACK PLUG, HILTI CP 777 SPEED PLUG FRICTION FITTED TO COMPLETELY FILL FLUTE FLUSH WITH BOTH SIDE OF WALL.
 3. [OPTIONAL] 2" WIDE x 10" LONG (MIN. 20 GA) STEEL STRAPS BUTTED AGAINST CEILING RUNNER ON BOTH SIDES OF WALL TO SPAN THE FLUTE AND SECURED TO FLUTED DECK WITH ONE STEEL FASTENER AT EACH END. WHEN STEEL STRAPS ARE USED, FIRESTOP TOP TRACK PLUGS MAY EXTEND MAX. 1/2" BEYOND STEEL STRAPS.
 4. AS AN ALTERNATE TO CEILING RUNNER IN ITEM 3, SLOTTED CEILING RUNNERS MAY BE USED. CONSULT THE UL FIRE RESISTANCE DIRECTORY FOR APPROVED MANUFACTURERS.
 5. L-RATINGS ARE NOT APPLICABLE WHEN SPRAY-APPLIED FIRE RESISTIVE MATERIAL IS USED.



Hilti Firestop Systems

HILTI, Inc.
Plano, Texas USA (800) 879-8000

Sheet 2 of 2

Scale -

Date Oct. 07, 2024

Drawing No.

**HWD
0871g**